

# DUAL LOOP CONTROLLER/PROGRAMMER

## RE19 TYPE



USER'S MANUAL





## Contents

<b>1. APPLICATION.....</b>	<b>5</b>
<b>2. BASIC REQUIREMENTS, OPERATIONAL SAFETY .....</b>	<b>6</b>
<b>3. INSTALLATION.....</b>	<b>8</b>
<b>4. SERVICE .....</b>	<b>13</b>
4.1. Description of the frontal plate .....	13
4.2. Loop selection.....	16
4.3. Fast change of the set point.....	17
4.4. Stoppage and restart of the automatic control .....	17
4.5. Screen with measurements .....	18
4.6. Manual operation .....	18
4.7. Review and change of parameters .....	21
4.8. Menu hiding .....	22
<b>5. CONTROLLER PARAMETERS.....</b>	<b>23</b>
<b>6. INPUT AND OUTPUT CONFIGURATION.....</b>	<b>31</b>
6.1. Input configuration .....	31
6.1.1. Main input .....	31
6.1.2. Auxiliary linear input.....	31
6.1.3. Digital filter .....	32
6.1.4. Logic inputs.....	33
6.2. Output configuration.....	35
6.2.1. Control outputs.....	35
6.2.2. Alarm outputs .....	36
6.2.3. Retransmission outputs .....	38
6.2.4. Signalling outputs.....	39

<b>7. LOOP CONFIGURATION .....</b>	<b>40</b>
7.1. Controlled signal .....	40
7.2. Kinds of control .....	40
7.3. Control range .....	42
7.4. Set point in the loop .....	43
7.5. PID parameters .....	43
<b>8. PROGRAM-FOLLOWING CONTROL .....</b>	<b>44</b>
8.1. Definition of programs .....	44
8.2. Program-following control .....	48
<b>9. SPECIAL FUNCTIONS .....</b>	<b>52</b>
9.1. Selection of PID controller settings .....	52
9.2. Measurement of two-wire line resistance.....	56
9.3. Return to factory settings .....	56
9.4. Automatic switching of loops.....	56
9.5. Change of user's language .....	57
<b>10. MESSAGES ON DISPLAYS .....</b>	<b>57</b>
<b>11. TECHNICAL DATA.....</b>	<b>58</b>
<b>12. ORDERING CODES .....</b>	<b>61</b>
<b>13. MAINTENANCE AND WARRANTY.....</b>	<b>62</b>

# 1. APPLICATION

The RE19 dual loop controller/programmer is destined to control temperature or other physical quantities, e.g. pressure, humidity, level, converted into an electric signal.

It can independently control two objects or two physical quantities in one object, e.g. in two-zone furnaces.

This controller is available in three versions:

- RE19 S** for standard (fixed set point) control,
- RE19 P** for standard control or programmed control
  - 15 programs with 15 segments in each program,
- RE19 V** for standard control by motorised valve control
  - at choice, 2 algorithms of stepper control, with or without feedback.

The controller can be equipped with the RS-485 interface with MODBUS protocol.

The set of each delivered controller includes:

- RE19 controller 1 pc.
- user's manual 1 pc.
- warranty card 1 pc.
- holder to fix in a panel 2 pcs.
- for controllers with interface:
  - user's manual for interface with MODBUS protocol 1 pc.
  - CD with the RE19prg for configuration 1 pc.

***When unpacking the controller, please check whether the type and version code on the data plate correspond to the order code.***

## 2. BASIC REQUIREMENTS, OPERATIONAL SAFETY



### **CAUTION!**

Designates a general useful note. If you observe it, handling of the instrument is made easier. One must take note of this, when the instrument is working inconsistently to the expectations.

### **Possible consequences if disregarded !**

In the security scope, the controller meets following requirements:

- operational safety: acc. to EN 61010 -1 standard,
- resistance against interference in industrial environment: acc. to EN 61000-6-2 standard,
- emission of electromagnetic noises: acc. to EN 61000-6-4 standard.

### **Remarks concerning the operator safety:**

#### **1. General**

- ◆ The RE19 controller is destined to be mounted in a panel.
- ◆ Non-authorized removal of the required housing, inappropriate use, incorrect installation or operation create the risk of injury to personnel or damage to equipment. For more detailed information, please study the user's manual.
- ◆ All operations concerning transport, installation, and commissioning as well as maintenance, must be carried out by qualified, skilled personnel and national regulations for the prevention of accidents must be observed.
- ◆ According to this basic safety information, qualified, skilled personnel are persons who are familiar with the installation, assembly, commissioning, and operation of the product and who have qualifications necessary for their occupation.

## **2. Transport, storage**

- ◆ Please observe the notes on transport, storage and appropriate handling.
- ◆ Observe the climatic conditions given in technical data.

## **3. Installation**

- ◆ The controller must be installed according to the regulation and instructions given in this user's manual.
- ◆ Before turning the controller on, one must check the correctness of connection to the network.
- ◆ In case of the protection terminal connection with a separate lead one must remember to connect it before the connection of the instrument to the mains.
- ◆ When working on live controllers, the applicable national regulations for the prevention of accidents must be observed.
- ◆ The electrical installation must be carried out according to the appropriate regulations (cable cross-sections, fuses, PE connection).

Additional information can be obtained from the user's manual.

- ◆ The documentation contains information about installation in compliance with EMC (shielding, grounding, filters and cables). These notes must be observed for all CE-marked products.
- ◆ The manufacturer of the measuring system or installed devices is responsible for the compliance with the required limit values demanded by the EMC legislation.

## **4. Operation**

- ◆ Measuring systems including RE19 controllers, must be equipped with protection devices according to the corresponding standard and regulations for prevention of accidents.
- ◆ After the controller has been disconnected from the supply voltage, live components and power connections must not be touched immediately because capacitors can be charged.
- ◆ The housing must be closed during operation.

## 5. Maintenance and servicing

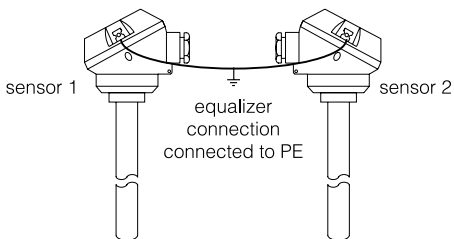
- ◆ Please observe the manufacturer's documentation.
- ◆ Read all product-specific safety and application notes in this user's manual.
- ◆ Before taking the controller housing out, one must turn the supply off.
- ◆ The removal of the controller housing during the warranty contract period may cause its cancellation.

## 3. INSTALLATION

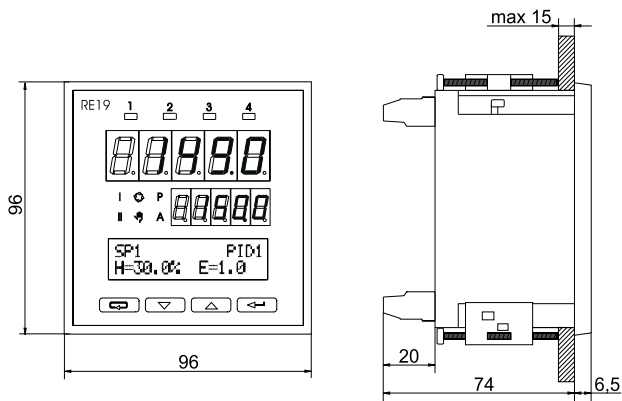
The controller is destined to be mounted in panels or cubicles. One must prepare a hole in the panel of 92-0.5 x 92-0.5 mm (fig.3.2). The material thickness which the panel is made of cannot exceed 15 mm. One must introduce the controller from the panel front without turning the supply on. After introducing the controller into the hole, fix it by means of holders. Make the connection of external signals acc. to fig 3.4. and 3.5.

In case of the controller operation in an environment with high interference one must apply external filters. It is recommended to use shielded wires connected with the PE wire of the supplying network on the controller input. As the power lead, use a two-wire cable. The wire cross-section should be chosen in order to assure the cable protection in the case of a cable short-circuit from the device side, by means of an installation cut-out.

In the application with two sensors, one must connect sensor metallic housings to PE (see fig. 3.1).

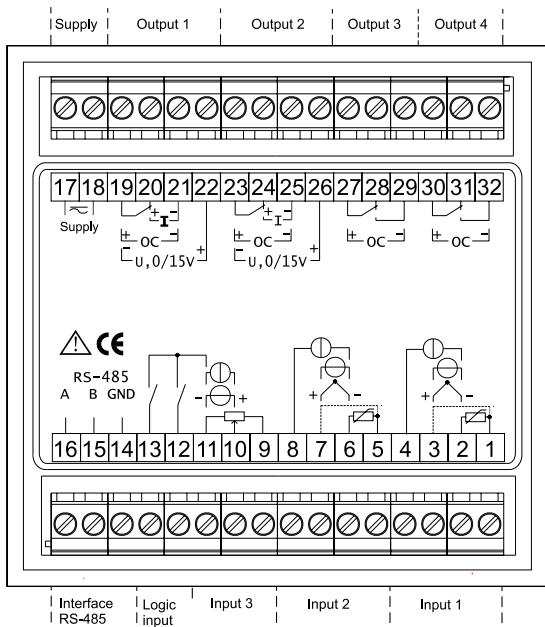


**Fig. 3.1. Connection of two sensors.**

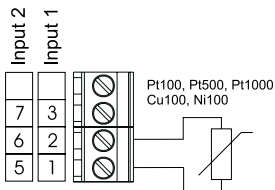


Panel cut-out: 92.0.5 × 92.0.5 mm

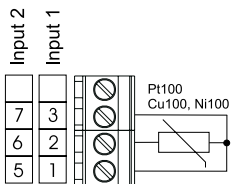
**Fig. 3.2. Controller overall dimensions.**



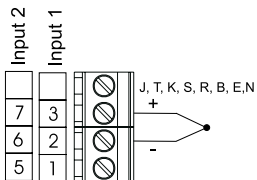
**Fig.3.3. Description of the terminal strip.**



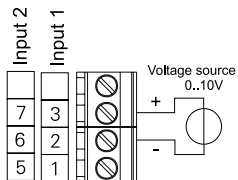
**a) RTD inputs in a 2-wire line**



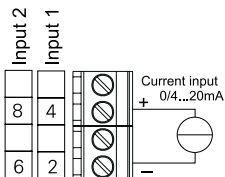
**b) RTD inputs in a 3-wire line**



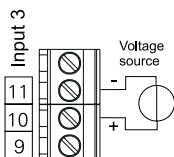
**c) Thermocouple inputs**



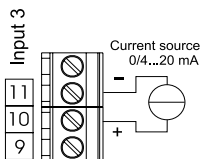
**d) Voltage inputs**



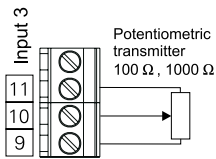
**e) Current input**



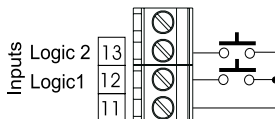
**f) Auxiliary voltage input**



**g) Auxiliary current input**

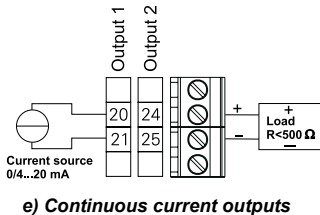
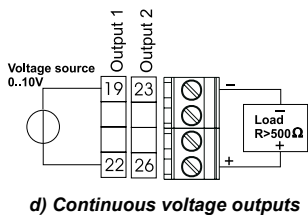
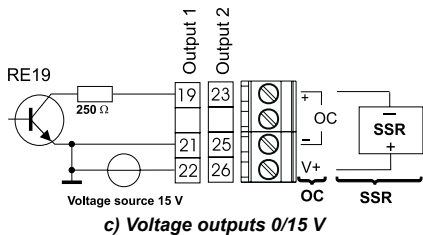
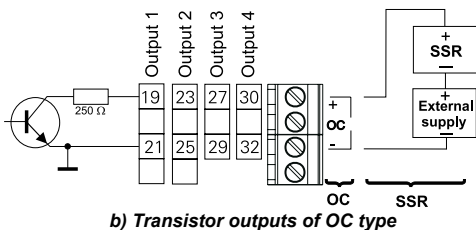
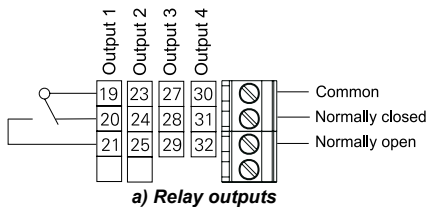


**h) Auxiliary potentiometric input**



**i) Logic inputs**

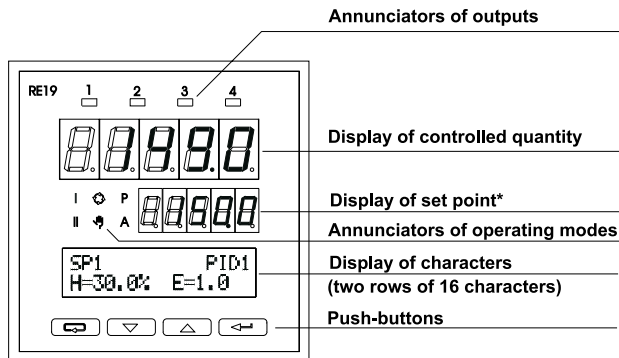
**Fig.3.4. Controller input connections.**



**Fig.3.5. Output connections.**

## 4. SERVICE

### 4.1. DESCRIPTION OF THE FRONTAL PLATE





\* The display of set point is flickering when the set point is beyond the loop control range.

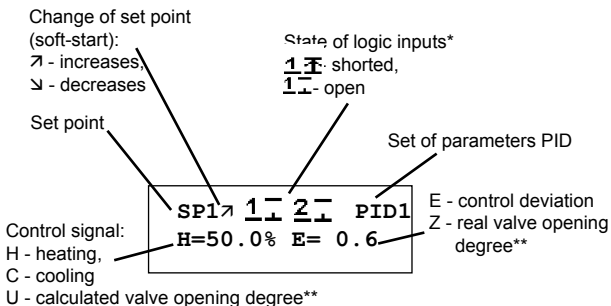
**Fig. 4.1. View of the frontal plate.**

After the controller turning on, the test of displays and annunciators is carried out, after which the controller displays the measured value, the set point and other parameters of the loop I or II.

## Function of annunciators:

<b>1 2 3 4</b>	signalling of outputs states; the flickering annunciator means that an alarm is occurred, which requires a confirmation
<b>I</b>	data on displays and operating mode annunciators concern the loop I
<b>II</b>	data on displays and operating mode annunciators concern the loop II
	signalling of automatic control in the chosen loop
	information that the set point in the chosen loop is changing (during the soft-start or programming control), the flickering annunciator means the lock or program stop
<b>A</b>	information that the automatic selection of PID parameters lasts in the chosen loop, the flickering annunciator means the function end.

Following information about the chosen loop is displayed on the character display:

















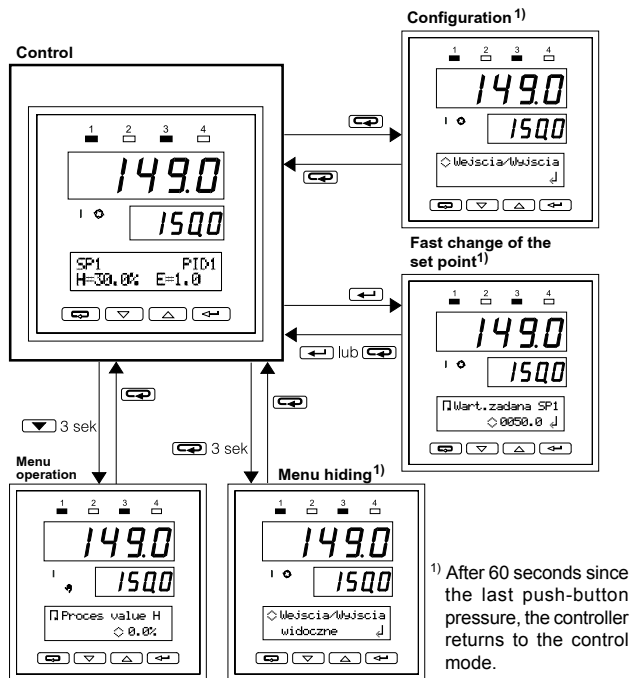
\* - States of logic inputs - appear when they are assigned to the loop.

\*\* - For RE19V, when control is according to the feedback

In RE19P controllers, other information can be shown on the display. Screens related to the program-following control were described in the chapter 8

## Push-button functions

Push-button	Control	Configuration	Manual operation
	<ul style="list-style-type: none"> <li>fast change of set point</li> <li>screen with information about the program (RE19P)</li> </ul>	<ul style="list-style-type: none"> <li>input to submenu</li> <li>acceptation of parameter value</li> </ul>	<ul style="list-style-type: none"> <li>switching of the circuit for heating-cooling control</li> </ul>
	<ul style="list-style-type: none"> <li>selection of the screen with measurements</li> <li>during 3 seconds - switching on manual operation</li> </ul>	<ul style="list-style-type: none"> <li>selection of the menu and parameters</li> <li>during the value change - decrease of numerical value or selection of the previous position</li> </ul>	<ul style="list-style-type: none"> <li>decrease of the control signal</li> </ul>
	<ul style="list-style-type: none"> <li>switching of loops</li> </ul>	<ul style="list-style-type: none"> <li>selection of the menu and parameter</li> <li>during the value change - increase of numerical value or selection of the next position</li> </ul>	<ul style="list-style-type: none"> <li>increase of the control signal</li> </ul>
	<ul style="list-style-type: none"> <li>switching on the configuration menu</li> <li>during 3 seconds - call of the hiding mode menu</li> </ul>	<ul style="list-style-type: none"> <li>return to the previous menu</li> <li>resignation of changes</li> </ul>	<ul style="list-style-type: none"> <li>turning the manual control off in the current loop</li> </ul>
 and 	<ul style="list-style-type: none"> <li>start of the control from the indicated segment (RE19P)</li> </ul>		
 and 	<ul style="list-style-type: none"> <li>stop or restart of the control</li> </ul>		
 and 	<ul style="list-style-type: none"> <li>alarm erasing</li> </ul>		
 and 			<ul style="list-style-type: none"> <li>monitoring of the second loop</li> </ul>
 and 			<ul style="list-style-type: none"> <li>turning the manual control on in the second loop</li> </ul>




**Fig.4.2. Transition diagram between controller operation modes**

## 4.2. LOOP SELECTION

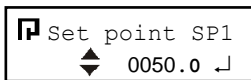
Annunciators I and II inform, to which loop are related data on displays and other annunciators:





If I is lighted, data concern the loop 1; if II is lighted, data concern the loop 2.


The change of the chosen loop follows after pressing the  push-button.

### 4.3. FAST CHANGE OF THE SET POINT

After pressing the  push-button, the screen appears (example):





One must set the new set point by means of  and  push-buttons and accept it by . The pressure of the  push-button causes the resignation of change.

In RE19P controllers, in the loop for which the program is the source of the set point, after pressing the  push-button, the information screen about the performed program appears.

The control of programs is described in the chapter 8

### 4.4. STOP AND RESTART OF THE AUTOMATIC CONTROL


The steering of the controller operation can be carried out in following ways:

1. from the keyboard: after the simultaneous pressure of  and  push-buttons, the stop or restart of the automatic control follows
2. from the logic input: if one of the logic input is defined as STOP and assigned to the loop, then the short-circuit of this input causes the stop of the automatic control, and the opening - the return to the automatic control.


*Note:*



*The logic input has a higher priority than the keyboard.*

3. from the computer: changing the register value 4123 for the loop 1 or 4124 for the loop 2 (see the user's manual for the serial interface with MODBUS protocol)



In the stopped control mode, the annunciator  is extinguished, the „CONTROL STANDBY” message appears on the character display, and assigned outputs for the loop are turned off.

#### 4.5. SCREEN WITH MEASUREMENTS

After pressing the  push-button, the screen appears. On this screen, after input numbers and colons, measured values and logic input states are displayed.


1: 850.0	2: 150.9
3: -39.99	 

Screen in the controller  
with an auxiliary input

1: 1350.0 °F	
2: -39.99 °C	



Screen in the controller without  
an auxiliary input


#### 4.6. MANUAL OPERATION

The switching on the manual operation in the current chosen loop is carried out after pressing and holding the  push-button during 3 sec.



The „**Process value H**” inscription appears in the upper type line of the character display when heating is realised in the loop, or the „**Process value C**” inscription when cooling is realised in the loop.



##### ***For the Heating and/or cooling control***

In the lower type line of the character display, the output signal value is displayed, which can be changed by the  or  push-button in the 0.0...100% range. The push-button holding causes the increase of the control signal change speed.



For the control with two **heating-cooling** circuits, the switching between the heating circuit and cooling circuit follows by the  push-button.


##### ***For the three-stage control (ValvePosition)***

The valve opening is carried out during the pressure of the , push-button, however the valve closing is carried out during the pressure of the  push-button. On the lower display, the valve state is given: **Opening, Closing, Stop**. For the „**acc. to Feedback**” algorithm, the valve opening state is also displayed.

When the second loop is not set in the manual operation, pressing simultaneously  and  push-buttons, one can turn its monitoring on.

The control signal in the manually controlled loop remains on the set value. During the loop monitoring, the controller configuration is not possible. The return to the manual operation follows after pressing any push-button.

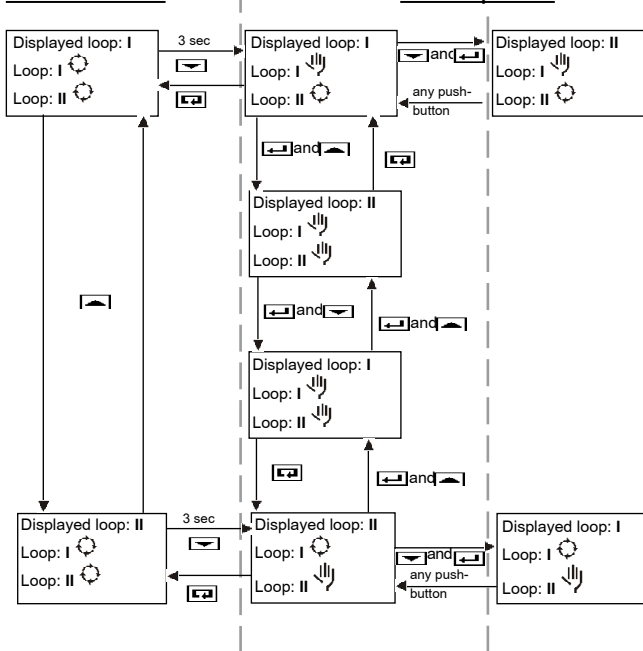
Pressing simultaneously  and  push-buttons, we turn the manual control on in the next loop, remaining the control signal in the previous loop on the set value.

The return of the defined loop to the automatic operation follows after pressing .



The algorithm of possible manual control calls is presented on the diagram 4.3.

### Automatic control

### Manual operation



**Fig.4.3. Manual control diagram**

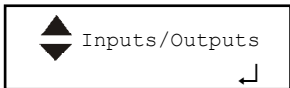
The symbol  on the diagram means the automatic control and the symbol  the manual control in the loop.




### Caution!


If the controller will be turned from the network off during the manual operation, the renewed supply connection causes the return to the manual operation from the lately set output signal.


## 4.7. REVIEW AND CHANGE OF PARAMETERS


One can enter into the configuration mode after pressing in the control mode. Following names are displayed on the character display: menu, submenu, parameters and their values, and push-button symbols.







The symbol  means, that after pressing the  or , the inscription shifts suitably into the next or previous position from the chosen menu.



The symbol  appears at the right side of the parameter and means that after pressing the push-button we can:

- ◆ review the chosen submenu,
- ◆ enter into the parameter change (after pressing the push-button, the symbol  is flickering before the being changed parameter),
- ◆ accept the value of the changed parameter.

The pressure of  push-button causes the resignation of changes or the return to the previous level.

### Change of the parameter value:


- ◆ we can change the value of numerical parameters by means of  and  push-buttons. A single pressure of these push-buttons changes the parameter value of 1; a longer holding causes the value changes of 10, and next by 100, etc.
- ◆ for textual parameters, successive values defined for the being changed parameter appear on the display after pressing the  or  push-button.

The acceptance of the introduced value follows after pressing , and the resignation of the introduced change, after pressing . If during 20 sec., none of push-buttons has been pressed, the controller enters into the parameter change mode, without changing its value.



**Caution!** The change of parameters can be reserved only for persons knowing the access codes.


There are three codes in RE19 destined for particular menu and functions (see table 1, **access code** menu). If the access code for the given menu is different from zero, then after entering into the configuration mode, the controller asks about its value (during the changing test of the first parameter of this menu, the **Give the K code** message appears).

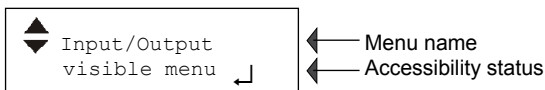
The return to the control mode follows after pressing the  push-button from the main menu or after 60 seconds since the last push-button pressure.

#### 4.8. MENU HIDING

After the configuration and checking the control on the object, one can hide particular groups of parameters, remaining only those which will be submitted to changes.


To hide the menu, one must:

- hold during ca 3 sec. the , push-button in the control mode till the screen appearance:



- select the menu which we want to hide and set the **hidden menu** status.

In order to restore the hidden menu one must:

- hold during ca 3 sec. the , push-button in the control mode till the screen appearance:



- choose the menu which we want to make accessible and set the **visible menu** status.

## 5. CONTROLLER PARAMETERS

Controller parameters have been divided into following groups (menu):

<b>Inputs / outputs</b>	parameters defining analog inputs, logic inputs and outputs
<b>Set points</b>	4 set points: <b>SP1</b> , <b>SP2</b> , <b>SP3</b> and <b>SP4</b>
<b>Programs</b>	definition of set point programs - only for RE19P
<b>PID parameters</b>	4 sets of PID parameters
<b>Alarms</b>	alarm parameters for outputs which have been configured as alarm outputs
<b>Modbus</b>	transmission parameters (for controllers with interface)
<b>Loop I and Loop II</b>	loop configuration
<b>Access codes</b>	definition of security codes
<b>Special functions</b>	start of the setting selection algorithm, measurement of 2-wire line resistance, return to factory settings, setting the time of screen switching, change of user's language

Submenu	Parameter	Range of changes <sup>1)</sup>	Parameter description
<b>Inputs / Outputs</b>			
<b>Analog input 1</b> <b>Analog input 2</b> <b>Analog input 3</b>	<b>Sensor</b>	<b>Pt100</b> . . .	Kind of connected measuring signal for the indicated input. See table 9 - List of input signals.
	<b>Unit<sup>9)</sup></b>	<b>Celsius</b> Fahrenheit	Unit in which the temperature is displayed. Only for RTD and TC inputs.
	<b>Wire Type</b>	<b>2-wire</b> 3-wire	Type of line conducting for RTD inputs
	<b>LeadResist.</b>	<b>0...20.0 Ω</b>	Resistance of conducting lines
	<b>CJmode</b>	<b>Auto</b> Manual	Way of reference junction temperature compensation for thermocouples: <b>Auto</b> - automatic Manual - from the thermostat
	<b>ExtTempCJC<sup>9)</sup></b>	<b>0.0...50.0°C</b> 32.0...122.0°F	Temperature of reference junction, when <b>Compensation</b> = Manual
	<b>DecPoint</b>	0, 1, 2	Number of digits after the decimal point for linear inputs - resolution of the measured and set point value on the display (Parameter = 0 for S, R and B thermocouples and = 1 for other sensors)
	<b>LowScale</b>	-9999... <b>0</b> ...55536 <sup>2)</sup>	Value corresponding to the lower limit of linear input range.
	<b>HighScale</b>	-9999... <b>100</b> ...55536 <sup>2)</sup>	Value corresponding to the upper limit of linear input range.
	<b>Offset<sup>9)</sup></b>	-9999... <b>0</b> ...55536 <sup>2)</sup>	Correction of the measurement with a constant component
	<b>Filter</b>	<b>Lack</b> 1 sec 2 sec 5 sec 10 sec 20 sec 30 sec 60 sec 90 sec 120 sec	Time constant of the low-pass digital filter


Submenu	Parameter	Range of changes <sup>1)</sup>	Parameter description
	<b>Event Input 1</b>		Functions of binary inputs
	<b>Event Input 2</b>	<p><b>Not used</b></p> <p>STOP</p> <p>Alarms Reset</p> <p>Lockout</p> <p>SP+1</p> <p>PID+1</p>	<p>The input function is not assigned</p> <p>Stops the automatic control</p> <p>Releases stored alarms</p> <p>Locks parameter changes from the keyboard</p> <p>Switches the set point on the next value</p> <p>Switches the PID parameters on the next set</p>
		<p>SPiPID+1</p> <p>SP+2</p> <p>PID+2</p> <p>SPiPID+2</p>	<p>Switches the set point and PID parameter on the next set</p> <p>Switches the set point by two positions</p> <p>Switches PID parameters by two positions</p> <p>Switches the set point and the PID parameter set by two positions</p>
	<p>Only in RE19P controllers</p>	<p>HoldbackPrg</p> <p>ProgramReset</p> <p>GotoNextSegm.</p>	<p>Stops the set point calculation</p> <p>Changes the open state into shorted and causes the program from the beginning</p> <p>Changes the open state into shorted state. Switches the realized segment on the next.</p>

Submenu	Parameter	Range of changes <sup>1)</sup>	Parameter description
Output 1 Output 2 Output 3 Output 4	Assigned to	<b>Loop1</b> (Out. 1 and 3)  <b>Loop2</b> (Out. 2 and 4)  In. 1 In. 2 In. 3 In1+In2+Ine3 In.bin 1 In.bin 2 In.bin 1 neg In.bin 2 neg Not used	Assignment of outputs to the loop or input   (In3 appears only in controllers with an auxiliary input)
	Function	Definition of the output operation way:	
		Not defined	
		<b>Heating</b> (Out.1 and 2)	Reverse control (in the valve motorized control, valve opening)
		Cooling	Direct control (in the valve motorized control, valve closing)
		<b>Alarm</b> (Out.3 and 4)	Alarms (see menu: Alarms)
		Event	Signalling in set point programmer control (see parameter: Sign.Source in RE19P)
		Retransmission	Retransmission of continuous signals (See parameter: Sign.Source)

Submenu	Parameter	Range of changes <sup>1)</sup>	Parameter description
	<b>Source</b> <sup>3)</sup>	<b>Set Point</b> ProcessValue Deviation	Quantity retransmitted on the continuous output assigned for the loop. (only when <b>Function</b> = Retransmission)
		Segment EndedPrg RunningPrg HoldbackPrg	Operation source of the signalling output in programming control (only in RE19P, when <b>Function</b> = Event)
	<b>AnalogType</b>	<b>0-20 mA</b> 4-20 mA 0-10 V 0-5 V	For analog outputs, selection of the linear signal and definition of the range
	<b>LowAnalog</b> <sup>9)</sup> <b>HighAnalog</b> <sup>9)</sup>	-999.9... <b>0</b> ...5553.6 <sup>4)</sup> -999.9... <b>100</b> ...5553.6	Range of retransmitted value [physical units]
<b>Set points</b>			
<b>SP1</b> <sup>9)</sup> <b>SP2</b> <sup>9)</sup> <b>SP3</b> <sup>9)</sup> <b>SP4</b> <sup>9)</sup>		-999.9... <b>0</b> ...5553.6	Set point 1 Set point 2 (physical units) Set point 3 Set point 4
<b>Programs</b>			
<b>Program 1</b>	<b>ConfigPrg</b>		Details in chapter 8
	<b>Segment 1</b>		
	, .		
	<b>Segment 15</b>		
<b>Program 15</b>	<b>ConfigPrg</b>		
	<b>Segment 1</b>		
	.		
	<b>Segment 15</b>		
<b>PID parameters</b>			
<b>PID1 set</b> <b>PID2 set</b> <b>PID3 set</b> <b>PID4 set</b>	<b>XP</b> <sup>9)</sup>	0.0... <b>30.0</b> ...6500.0	Proportional band [physical unit]
	<b>ti</b>	0... <b>300</b> ...9999	Integration time-constant [sec.]
	<b>td</b>	0... <b>60</b> ...3000.0	Differentiation time-constant [sec.]
	<b>H</b> <sup>9)</sup>	0.0... <b>1.0</b> ...999.9	Hysteresis [physical units]
	<b>to</b>	1... <b>20</b> ...999	Pulse repetition period [sec.]
	<b>Y0</b>	<b>0.0</b> ...100.0	Correction of the control signal for PD control [%]

Alarms			
Alarm 1 Alarm 2 Alarm 3 Alarm 4	TypeAI	FullScaleHigh FullScaleLow DeviationHigh DeviationLow DeviationBand Deviationinband	Kind of alarm on the indicated output
	SP.AI. <sup>9)</sup>	-999.9... 0 ...5553.6	Alarm operation value [physical units]
	Hi.AI. <sup>9)</sup>	0.0...1.0...999.9	Hysteresis for the alarm [physical units]
	Latch	Yes, no	Alarm store
Parameter	Range of changes	Parameter description	
Modbus			
Address	0...247	Controller address in the network	
Baud	2400 4800 <b>9600</b> 19200	Baud rate [bit/sec.]	
Mode	Off ASCII8n1 ASCII7E1 ASCII7o1 RTU 8n2 RTU 8E1 RTU 8o1 RTU 8n1	Transmission mode: off - transmission turned off ASCII, 8 data bits, without parity check, 1 stop bit ASCII, 7 data bits, parity check, 1 stop bit ASCII, 7 data bits, odd parity check, 1 stop bit RTU, 8 data bits, without parity check, 2 stop bits, RTU, 8 data bits, parity check, 1 stop bit, RTU, 8 data bits, odd parity check, 1 stop bit RTU, 8 data bits, without parity check, 1 stop bit	
Loop 1 Loop 2			
ProcessValue	In1 (loop I) In2 (loop II) In3 In1+In2 In1+In3 In2+In3	Input number from which the controlled signal in the loop is read out.  For the signal coming from two inputs, one must give additionally, coefficients by which particular input signals are multiplied by.	

Parameter	Range of changes	Parameter description
<b>Multiplier A</b>	-9.9... <b>1.0</b> ...9.9	Coefficient, which the first component of the controlled signal is multiplied by.
<b>Multiplier B</b>	-9.9... <b>1.0</b> ...9.9	Coefficient, which the second component of the controlled signal is multiplied by.
<b>ControlType</b>		Kind of control realized in the loop:
	None	- the loop is not used
	<b>Heating</b>	- reverse control
	Cooling	- direct control
	Heat-Cooling <sup>5)</sup> Valve Pos.	- control with two lines (heating and cooling) - three-stage step control (only in RE19V)
<b>Ct1LowLimit</b> <sup>9)</sup>	-999.9... <b>0</b> ...5553.6 <sup>2)</sup>	These parameters define the control range and the range of set point changes in the loop (physical units)
<b>Ct1HighLimit</b> <sup>9)</sup>	-999.9... <b>100</b> ...5553.6 <sup>2)</sup>	
<b>SetPoint</b> <sup>9)</sup>	<b>SP1</b> (loop I) <b>SP2</b> (loop II) SP3 SP4 REM PRG <sup>5)</sup>	Set point assigned to the loop (REM -from the auxiliary input; PRG - set point from the program - Only in RE19P)
<b>ProgramNr</b>	<b>1...15</b>	The set point program number assigned to the loop - only in RE19P
<b>Ramp Rate</b> <sup>9)</sup>	<b>0.00</b> ...99.99	Accretion of the set point during the soft-start (physical units /min) , only for SP1...SP4 0.0 means, that the soft-start is turned off
<b>PID Set</b> <b>PID(1) Set</b> <sup>8)</sup> <b>PID(2) Set</b> <sup>8)</sup>	<b>PID1</b> (loop I) <b>PID2</b> (loop II) PID3 PID4	Set of PID parameters assigned to the loop
<b>Displacement</b> <sup>9)</sup>	0.0... <b>1.0</b> ...999.9	Displacement between two lines during the control of heating+cooling type [physical units]
<b>Dead band</b> <sup>9)</sup>	0.0... <b>1.0</b> ...999.9	Dead band in the valve type control [physical units]
<b>Feedback</b>	no yes	Algorithm for the valve control (only in RE19V)
<b>Event inputs</b>	<b>Not used</b> In.Log1 In.Log2 In.Log1+2	Allocation of logic inputs to the loop

Parameter	Range of changes	Parameter description
<b>Autotuning</b>		Algorithm of PID parameter selection
	<b>No use</b> <sup>5)</sup> Identification Oscillations	turned off On the base of object identification On the base of oscillations around the set point
<b>Access codes</b>		
<b>Code 1</b>	0...9999 0 means a lack of security	Security code for the <b>Input/Output</b> and <b>Modbus</b> menu and the function of two-wire line resistance measurement. <b>LineResistMeasur.</b>
<b>Code 2</b>		Security code for <b>PID Parameters and Alarms</b> menu
<b>Code 3</b>		Security code for <b>Loop 1</b> and <b>Loop 2</b> menu and calling the function of automatic setting selection - <b>PID Selection</b>
<b>Special Functions</b>		
<b>PID selection</b> <sup>6)</sup>	Loop 1 Loop 2	Starts the algorithm of setting selection defined in the loop configuration.
<b>LeadResistance</b> <sup>7)</sup>	Input 1 Input 2	Measures the resistance of the two-wire line on the indicated input.
<b>Default Values</b>	<b>Reset</b>	After pressing the  push-button, the controller restores factory parameter settings.
<b>Change of loop</b>	0...20	0...2 - the alternate display is turned off 3...20 - time of the loop switching in seconds
<b>Language</b>	Polish English	

- 1) Factory settings are printed in bold type
- 2) The value has the decimal point on the position defined by the **DecPoint** parameter
- 3) Parametr appears depending on the output function
- 4) The range of parameter changes depends on that, what quantity is retransmitted:  
- for the control deviation: from -100.0 to 100.0  
- for the controlled and measured signal: in the measuring input range  
- for the set point: in the control range
- 5) For the control with two heating-cooling lines and for the program-following control, the automatic selection of PID parameters is not possible, and for this reason the **Autotuning** parameter accepts the **No use** value and one cannot change it.
- 6) The function appears only when during the loop configuration, the **Autotuning** parameter is set on a value different from **No use**
- 7) The function appears only when during the input configuration a resistance input with a two-wire line has been chosen
- 8) Positions appear if the heating-cooling control is realized in the loop
- 9) After changing the **unit** parameter from Celsius degrees into Fahrenheit degrees or inversely, one must set again parameter values, which are given in physical units since the controller does not recalculate them automatically.

## 6. CONFIGURATION OF INPUTS AND OUTPUTS

### 6.1. CONFIGURATION OF INPUTS

The RE19 controller has as standard, two universal inputs, and optionally an auxiliary linear and two logic inputs.

#### 6.1.1 Main input

The RE19 controller has two universal inputs, which one can connect any signal to - see table 9.

During the input configuration (**Input/Output** menu, **AnalogInput 1** and **AnalogInput 2** submenu), one must give what type of signal is connected to the indicated input (**Sensor** parameter), and next, parameters depending on the chosen signal type:

- ◆ for RTD inputs:
  - unit to display the temperature: °Celsius or °Fahrenheit,
  - the type of the leading line - **WireType** parameter; in case of a two-wire line give the **LeadResist.** line resistance (or use the special function of line resistance measurement: **LeadResistance**),
- ◆ for thermocouples:
  - unit to display the temperature: °Celsius or °Fahrenheit,
  - the way of the cold junction temperature compensation - **CJ mode** parameter,
    - the **Auto** value means measurement and automatic compensation,
    - the **Manual** value means a constant temperature of cold ends defined in the **ExtTempCJC** parameter,
- ◆ for linear inputs:
  - the display resolution of the measured value - **DecPoint** parameter,
  - define the value of **LowScale** and **HighScale** parameters corresponding suitably to the input signal range.

#### 6.1.2. Auxiliary linear input

In the **Input/Output** menu, **AnalogInput 3** submenu, one must give:

- ◆ the input type (**Sensor** parameter),
- ◆ the display resolution of the measured value (**DecPoint** parameter),

- ◆ values corresponding to the measuring range (**HighScale** and **LowScale** parameters).

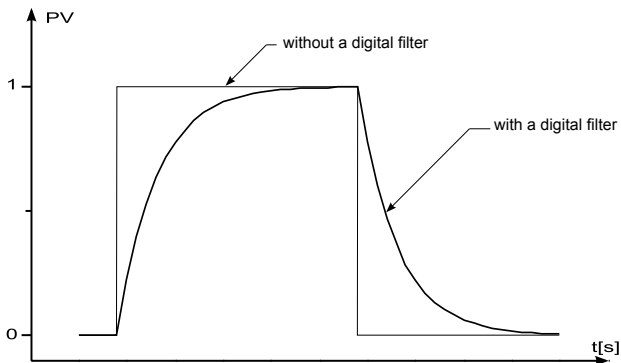
**The auxiliary input can be used as:**

- ◆ controlled signal for any loop (as an independent input or as a constituent for a complex controlled signal, e.g. sum or difference of signals),
- ◆ set point for an optional loop - then, set the **Set point** parameter on **In3** during the loop configuration,
- ◆ auxiliary measuring point - the value measured on the input can be seen on the measuring screen,
- ◆ feedback from the valve, on the base of which the valve type control algorithm is realized (only in RE19V).

### 6.1.3. Digital filter

In case when the measured value is instable, one can switch the programmed digital low-pass filter.

The time-constant is defined to reach 99.9% of the measured value. A high time-constant can cause a control instability.




**Fig.6.1. Time characteristic of the filter.**

#### 6.1.4. Logic inputs

Logic input functions are defined during the input configuration (**Input/Output** menu) by **Event Input 1** and **Event Input 2** parameters. Next, in **loop 1** and/or **loop 2** menu, one must assign logic inputs to particular control loops. One can allocate one or both logic inputs to one loop.

##### **Functions of logic inputs:**

<b>no used</b>	the state of the logic input does not influence the controller operation
<b>Standby</b>	the contact short-circuit means the turning of controlled outputs and alarms off. The input opening causes the return to the automatic control.
<b>AlarmsReset</b>	the contact short-circuit causes the turning of stored alarms off,
<b>Lockout</b>	the contact short-circuit causes the locking of parameter changes during the controller configuration - After pressing the  push-button, the <b>ChangeLocking!</b> message appears. The holdback mode does not concern SP1...SP4 set points.
<b>SP+1</b>	for fixed set point control - the short-circuit of contacts causes the switching of the set point on the next from the value set {SP1, SP2, SP3, SP4}. For the SP4 set point, the next set point is SP1. The switching of the set point takes into consideration the accretion rate of the set point in the loop (soft-start). The opening of contacts causes the return to the previous set point.

<b>PID+1</b>	the contact short-circuit causes the switching of the PID parameter set on the next set {PID1, PID2, PID3, PID4}. For the PID4 set, PID1 is the next. The switching between parameter sets is percussiveless (the control signal changes fluidly).
<b>SPiPID+1</b>	the contact short-circuit causes the switching of the set point on the next and the PID parameter set on the next.
<b>SP+2</b>	the contact short-circuit causes the switching of the set point by two positions from the value set {SP1, SP2, SP3, SP4}. E.g. SP1 will be switched on SP3, SP4 on SP2, etc. The contact opening causes the return to the previous value.
<b>PID+2</b>	the contact short-circuit causes the switching of the PID parameter set by two positions from the {PID1, PID2, PID3, PID4} set.
<b>SPiPID+2</b>	the contact short-circuit causes the switching of the set point and PID set by two positions from suitable sets.
<b>HoldbackPrg</b>	the contact short-circuit causes the stoppage of the set point counting. The control is carried out acc. to the last counted value. The contact opening causes the program continuation (only in RE19P).
<b>ProgramReset</b>	The change of contact state, from opened to short-circuited, causes the return of the program to the initial state (only in RE19P).
<b>GotoNextSegment</b>	The change of contact state, from opened to short-circuited, causes the jump to the next segment in the program (only in RE19P).

## 6.2. CONFIGURATION OF OUTPUTS

The RE19 controller has 4 outputs defined by a version code. Outputs are configurable, i.e. for each output, one must define the allocation and function. For continuous outputs, one must additionally define the type of signal - voltage or current.

### 6.2.1. Control outputs

- ◆ The output with **Heating** function is a reverse output. It is an output used in control during which the increase of the controlled signal value causes the decrease of the output signal value. The output of such a function will be assigned during the loop configuration for the heating control type or for the heating line in the control of heating+cooling control or for the valve opening in the valve position control.
- ◆ The output with **Cooling** function is a non-reverse (direct) function. It is an output used in control during which the increase of the controlled signal causes the increase of the output signal value. The output of such a function will be assigned during the loop configuration for the control of cooling type, for the cooling circuit in the control of heating-cooling type or for the valve closing in the valve position control.

In the discontinuous control, in which relay or transistor outputs are used to control actuators, the pulse repetition period is the essential parameter.

This is the time which elapses between successive switchings of the output during the proportional control. The duration of the pulse repetition period can be matched depending on object dynamic properties and suitably the output device. For quick processes it is recommended to use SSR relays. The output relay is used to control contactors in slow-changing processes.

The use of a high pulse repetition period to control quick-changing processes can give undesirable effects in the shape of oscillations. Theoretically, the smaller the pulse repetition period, the better

control is, however, for the relay control, the pulse repetition period should be as higher as possible in order to prolonge the relay life.

The **to** pulse repetition parameter is given during the definition of PID parameters in the **PIDk Set** menu.

Recommendations concerning the pulse repetition period:

Output	Pulse repetition period <b>to</b>	Load
Electromagnetic relay	recommended >20 sec min. 10 sec	2 A/230 V a.c. or contactor
	min. 5 sec	1 A/230 V a.c.
Transistor output	1...3 sec	semiconductor relay (SSR)

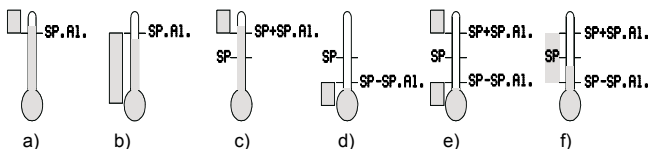
### 6.2.2. Alarm outputs

The alarm configuration is carried out in a two-step way:

- In the **Output k** submenu - where  $k=1...4$  (**Outputs/Inputs** menu), one must set:
  - ◆ in the **Assigned to** parameter, the loop or input number which the configured input is assigned to,
  - ◆ In the **Function** parameter, one must choose the **Alarm** position.
- In the **Alarms** menu, for each of defined outputs as **Alarm**, one must set:
  - ◆ The kind of alarm (**TypeAI** parameter, see fig. 6.1.)  
The alarm output assigned to the loop can act as an absolute alarm or relative alarm.  
The alarm output assigned to the measuring input can act only as an absolute alarm.

- ◆ The set point - **SP.AI.**- for absolute alarms is the controlled or measuring signal value which causes the turn of the output on. For relative alarms - it is the value of the control deviation value which causes the turn of the output on.
- ◆ Hysteresis of the output turning on - **AI.HY.** - It is the zone around the **SP.AI.** value, in which the output state is not changed.
- ◆ Alarm store - (**Latch** parameter)

**Yes** - means that the alarm occurrence will be „latched” till the moment when the operator does not confirm its occurrence. The diode of the stored alarm is flickering.



**Fig.6.2. Kinds of alarms**

- a) upper absolute
- b) lower absolute
- c) upper relative

- d) lower relative
- e) external relative
- f) internal relative

**SP** - set point

**SP.AI.** - alarm set point

### **Confirmation of stored alarms**

Output alarms, for which the **Latch** parameter is set on **Yes**, are not turned off, despite that conditions of their occurrence are not current - controller outputs are active (annunciators of suitable outputs are flickering) till the operator does not confirm them.

Alarms can be confirmed in two ways:

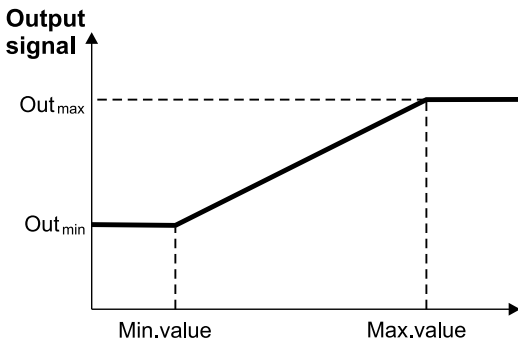
1. from keyboard - through the simultaneous pressure and push-buttons. In this way, all stored alarms are erased.

- by logic input - if one of the logic input is configured as **Reset.Alarms** and assigned in the loop in the **Event Inputs** parameter, then the short-circuit of this input causes the reset of alarms related to this loop.

### 6.2.3. Retransmission outputs

Continuous outputs can be used to the retransmission of the chosen quantity, e.g. in order to record the temperature in the object or copy the set point in multi-zone furnaces. For this aim, during the configuration of the continuous output, one must:

- choose the **Retransmis.** value in the **Function** parameter,
- choose the retransmitted signal in the **Source** parameter for outputs assigned to the loop:
  - **ProcessValue** - controlled signal,
  - **Deviation** - control deviation,
  - **Set Point** - set point,
- choose the type and range of the continuous output:  
**0-20 mA, 4-20 mA, 0-10 V, 0-5 V**
- define controlled signal values corresponding to output ranges - see fig. 6.3. This allows to retransmit the chosen quantity in the interested range with a satisfied precision.



*Fig.6.3. Calibration of the retransmission continuous output*

## 6.2.4 Signalling outputs

Any optional outputs can be used in the RE19 controller to signal measuring input damages or for the „retransmission” of the indicated logic input state.

For this aim, one must select following positions in the **Assigned to** parameter:

- **In1** - overflow of the input 1 range causes the output activity
- **In2** - overflow of the input 2 range causes the output activity
- **In3** - overflow of the input 3 range causes the output activity
- **In1+In2+In3** - overflow of the range of any input causes the output activity
- **Logic 1 used** - short-circuit of the logic input 1 causes the output activity
- **Logic 2 used** - short-circuit of the logic input 2 causes the output activity
- **Logic 1 not used** - opening of the logic input 1 causes the output activity
- **Logic 2 not used** - opening of the logic input 2 causes the output activity

In RE19P controllers, signalling outputs have auxiliary functions used during the program-following control. One must choose **Loop 1** or **Loop 2** in the **Assigned to** parameter, choose Event value in the **Function** parameter, and next, define the output action conditions in the **Source** parameter:

- **Segment Event** - turned on in defined segments in the program, see chapter 8,
- **Ended Prg** - turned on after the program ending in the loop,
- **Running Prg** - turned on during the program realization in the loop,
- **Holdback Prg** - turned on, when the active counted lockout of the set point is in the program.

## 7. CONFIGURATION OF LOOPS

### 7.1. CONTROL SIGNAL

The control signal in the loop can be the measurement from the indicated input (**In1, In2, In3**) or the combination of the measuring values from two inputs. The complex control signal is counted through the controller from the formula:

Controlled

signal = **MultiplierA**\*(measurement X) + **MultiplierB**\*(measurement Y)

where measurement X and measurement Y, are suitably the first and the second component of the sum.

#### **Example 1**

To control the difference of signals from input 2 and input 3, one must write:

**PV input = In2+In3; MultiplierA = 1.0 MultiplierB = -1.0**

#### **Example 2**

To control the arithmetic mean of signals from the input 1 and input 2 one must write:

**PV input = In1+In2; MultiplierA = 0.5 MultiplierB = 0.5**

### 7.2. KINDS OF CONTROLS

Apart from basic kinds of control i.e. heating or cooling, the control with two circuits is accessible, and in the RE19V controllers - valve position control.

#### **Control of heating type**

The controller realizes this type of control when the **ControlType** in the **Loop 1** or **Loop 2** menu is set on **Heating**. That is the reverse control (inverse), during which, the increase of the control signal value causes the drop of the output signal value. During the configuration, the output assigned to the loop must have set the **Heating** function.

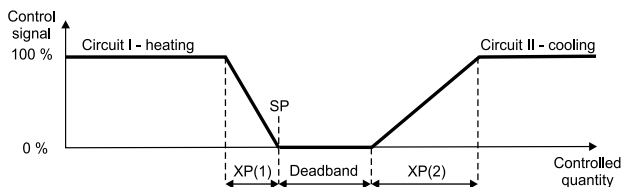
#### **Control of cooling type**

The controller realizes this type of control when the **ControlType** in the **Loop 1** or **Loop 2** menu is set on **Cooling**. That is the non-reverse control (direct), during which, the increase of the control signal value causes the increase of the output signal value.

During the configuration, the output assigned to the loop must have set the **Cooling** function.

### **Control with two circuits of heating-cooling type**

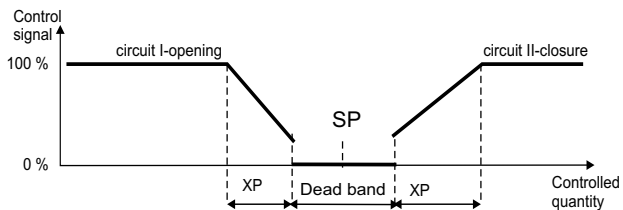
The controller realizes this type of control when the **ControlType** parameter is set on **Heating-Cooling**. For each control circuit, one must assign the PID parameter set - **PID Set (1) and PID Set (2)** parameters. Moreover, one must define the **Deadband** parameter - parameter which defines the set point for the second circuit. During the configuration, outputs assigned to the loop must have set the **Heating** and **Cooling** functions.



**Fig.7.1. Control with two heating-cooling circuits**

### **Three-stage valve position control (RE19V)**

In RE19V controllers, two algorithms of valve control for actuator control are accessible. To realize this type of control, one must set the **ControlType** parameter on **ValvePosition**. One must also define the dead band around the set point, in which the valve does not change its position - **DeadBand** parameter.



**Fig.7.2. Valve control**

The valve opening is carried out through the output with **Heating** function, and closing through the **Cooling** function. Two valve control algorithms are at choice:

- Without feedback signal from the valve - opening and closing the valve is carried out on the base of PID parameters and control deviation,
- With feedback signal from the valve position device - opening and closing the valve is carried out on the base of PID parameters, control deviation and the valve position read out from the **In3** auxiliary input. For this type of control, the counted position of the valve **U** and the real position of the valve **Z** are displayed in percentage on the information screen. The controller aims to set the valve in the position **U**.
- When the controller deviation is in the dead band, then instead of the control signal, the inscription **STOP** is displayed.

### 7.3. CONTROL RANGE

The control range defined by **SPLowLimit** and **SPHighLimit** quality the range to which the **XP** proportional range, given in physical units is reported during the definition of the amplification coefficient  $K_p$  of the object.

Moreover, **LowControlThreshold** and **HighControlThreshold** define range changes of the set point in the loop (i.e. during a fast change of the set point) and conditions to start the object identification algorithm (see paragraph 9.1, table 7).

$$K_p = \frac{100}{XP * \frac{100}{HighControlThreshold - LowControlThreshold}} = \frac{HighControlThreshold - LowControlThreshold}{XP}$$

The output signal **Y** is calculated from the equation:

$$Y = K_p * \left( e + \frac{TP}{ti} \int e(t) dt + \frac{td}{TP} * \frac{de(t)}{dt} \right)$$

where **e** = control deviation expressed in % of the control range:

$$e = \frac{SP - PV}{HighControlThreshold - LowControlThreshold} * 100\%$$

**TP** - sampling period [sec] (see table 10)

**ti** - integration time constant [sec]

**td** - differentiation time constant [sec]

**SP** - set point [physical units]

**PV** - measured value [physical units]

#### 7.4. SET POINT IN THE LOOP

The set point in the loop can be one of four values defined under **SP1, SP2, SP3, SP4** names, the value read out from the **In3** auxiliary input or one of the **PRG** programs (only in RE19P).

If the set point is not situated in the control range in the given loop, then it is set on a suitable low and high range, and the set point display is flickering.

#### Soft-start

If the value is controlled in the loop acc. to **SP1, SP2, SP3** or **SP4**, one can define the admissible rate of controlled signal changes (so-called: soft-start) during the object start or during the set point change. This allows to a mild access to the in-coming set point without overshoots. Instantaneous set point changes from the measuring value at the moment of the counting start to the assigned set point to the loop (or to the control threshold).

The accretion rate of the instantaneous set point is defined in the **RampRate** parameter (in units/minute).

The  $\nearrow$  symbol appears on the character display when the set point value increases, and the  $\searrow$  symbol when the set point value decreases.

#### 7.5. PID PARAMETERS

Four PID parameter sets: **PID1, PID2, PID3, PID4** create the parameter bank from which, one can profit during the loop configuration.

Control algorithms

Table 2

Algorithm	Parameter				
	XP	ti	td	Y0 <sup>1)</sup>	Histeresis
On/ Off	0.0	Without significance	Without significance	Without significance	>=0.0
P	>0.0	0.0	0.0	>=0.0 <sup>2)</sup>	Without significance
PI	>0.0	>0.0	0.0	Without significance	Without significance
PD	>0.0	0.0	>0.0	>=0.0 <sup>2)</sup>	Without significance
PID	>0.0	>0.0	>0.0	Without significance	Without significance

1) The parameter is considered when **ti=0**

2) The parameter value is not taken into consideration for the valve control without feedback signal from the valve .

The controller can automatically select PID parameters (see chapter 9.1.)

## 8. PROGRAM-FOLLOWING CONTROL

### 8.1. DEFINITION OF PROGRAMS

Programs of the set point are defined in the **Programs** menu. Each program is composed of parameters concerning the whole program and parameters concerning particular segments (no more than 15). The table below presents parameters related to the program definition

Table 3

Parameter name	Ranges of changes	Explanation
<b>ConfigPrg - program parameters</b>		
<b>StartValuePrg</b>		Definition of the value from which the program begins from.
	<b>StartSP</b>	Start from the set point in the <b>StartValuePrg</b> parameter
	<b>StartWM</b>	Start from the currently measured value.
<b>Time Unit</b>		Time units for segments, for which one must give the duration.
	<b>min:sec</b> <b>hour:min</b>	minutes:seconds hours:minutes
<b>RampSegmType</b>		Way to define segments in which the set point is variable in.
	<b>Time Ramp Rate</b>	Duration of the segment Accretion rate of the set point
<b>HoldbackMode</b>		Definition if there is a controlled control deviation in the program. After its overflow, the counting of the set point is stopped.
	<b>No</b>  <b>Yes</b>	The program does not control the deviations.  For each segment, one must give the admissible deviation quantity ( <b>HoldbackMode</b> parameter)

<b>PowerFailRecov</b>		Definition of control restart after a supply decay.
	<b>No</b>	The controller waits for the operator decision.
	<b>Yes</b>	The program is continued <sup>1)</sup> .
<b>NumberOfCycles</b>	1...99	Number of cycles to carry out.
<b>StartSPoint</b> <sup>3)</sup>	-9999... 0.0...55536	Initial set point value in the program when the <b>StartPrg</b> parameter is set on <b>StartSPoint</b>
<b>Segment 1...15 - Parameters related to segments</b>		
<b>RampRate (n)</b> n = 1...15 n = segment number	0.00...99.99	Rate of set point changes [physical units/minute] 0.00 means the segment with a constant set point.
<b>SegDuration (n)</b>	00:00...99:59	Segment duration in units given in <b>TimeUnit</b>
<b>Target SP (n)</b> <sup>3)</sup>	-9999...55536	Set point on the segment end
<b>HoldBackVal (n)</b> <sup>3)</sup>	0...99.9	Value of the control deviation in the segment, after overflowing of which, follows the deadlock of the set point counting (when the <b>HoldBackVal</b> parameter = <b>Yes</b> ) <sup>2)</sup> The „0” value means that the control deviation in the segment does not cause the deadlock of the programmer.
<b>Event outs (n):</b>	During the review of the program, the output state in the segment is signalled by symbols: $\bar{1}$ for the output turned off, and $\bar{1}$ - for the output turned on.	
<b>Out State k</b> k=1...4	<b>Off</b> <b>On</b>	The output state k in the segment (when outputs in the controller are configured as signaling and the <b>Signal Source</b> parameter = <b>Segment event</b> ).

- 1) - when the **RampSegmentType** parameter equal **Time**, then the program continues from the set point and time which were at moment of supply decay.  
 - when the **RampSegmentType** parameter equal **RampRate**, then the program continues from:  
 a) currently measured value for segments with slope,  
 b) from set point and time which were at the moment of supply decay for segment with holding.
- 2) - for segments, which the set point increases in, the locking is realized from the positive deviation (the object does not follow with the heating),

- for segments, which the set point decreases in, the locking is realized from the negative deviation (the object does not follow with the cooling),
  - for segments, which the set point is maintained on a constant level, the locking in realized from the positive and negative deviation.
- 3) - After changing the **unit** parameter from Celsius degrees into Fahrenheit degrees or inversely, one must set again parameter values, which are given in physical units since the controller does not recalculate them automatically.

The program can have less than 15 segments. Then, after defining the last used segment, one must give 0 for **SegDuration** and **RampRate** in the next segment.

### Example of program

Let's define the program 1 acc. to the fig.8.1, in which the control begins from the measured value in the object.

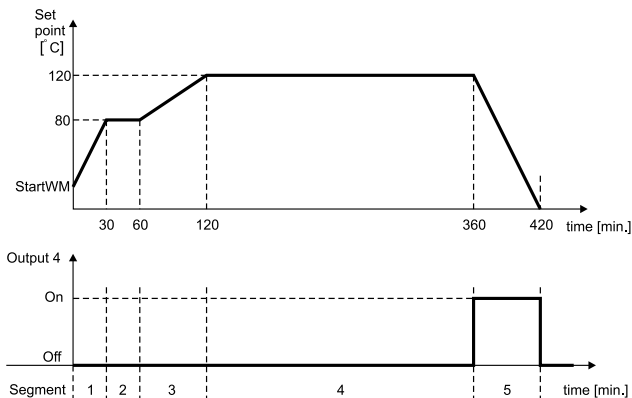
In segments, in which the set point increases, one must check the magnitude of the control deviation (10.0°C and 5.0°C) and signal, when the admissible deviation will be exceeded.

One must turn the fan on, in the last segment.

The program is to be started by the logic input.

The loop 1 will be used for control.

The table 4 contains parameter values in the exemplary program and input and output parameters.



**Fig.8.1. Exemplary program of the set point and logic output**

Submenu	Parameter name	Value	Explanation
<b>Inputs / Outputs</b>			
	Event Input 1	Program Reset	The short-circuit of the input starts the program from the beginning
Output 1	Assigned to	Loop 1	
	Function	Heating	
Output 2	Assigned to	Loop 1	
	Function	Event	
	Source	HoldbackPrg	The output is active when the lockout of the control deviation is turned on
Output 4	Assigned to	Loop 1	
	Function	Event	
	Source	Segment	Output state in individual segments of the program.
<b>Programs</b>			
Program 1/ ConfigPrg	StartValuePrg	PVmode	Program begins from the current value controlled in the object
	Time Unit	hours:min	Duration of segments is given in hours and minutes
	RampSegmentType	time	For segments with variable set point, the time to reach the in-coming value is given
	HoldBackMode	Yes	One must check if the object follows the program
	PowerFail-Recov	Yes	After the supply decay, one must carry on the program.
	Number of Cycles	1	The program must be performed once

<b>Segment</b>						
	1	2	3	4	5	6
SegDuration	00:30	00:30	01:00	04:00	01:00	00:00
TargetSP	80.0	80.0	120.0	120.0	20.0	0.0
HoldBackValue	10.0	0.0	5.0	0.0	0.0	Without significance
State out 4	Off	Off	Off	Off	On	

Parametr name	Value	Explanation
<b>Loop 1</b>		
<b>PV input</b>	<b>Input 1</b>	
<b>ControlType</b>	<b>Heating</b>	
<b>SP Select</b>	<b>PRG</b>	
<b>Program No</b>	<b>01</b>	The acceptance of the program number causes the control turn off in the loop; the start of the program-following control is described in the chapter 8.2. <b>Control of programs.</b>
<b>Event Inputs</b>	<b>Logic used</b>	

During the program review, the output state in the segment is signalled by symbols:  $\underline{1}$  - for the output turned off, and  $\overline{1}$  - for the output turned on.

## 8.2. PROGRAM - FOLLOWING CONTROL

During the program-following control, following information about the chosen loop appears on the character display (called *Loop screen*).

Program number acc. to which the control in the loop is realized

State of the logic input

PID parameter set

Programmed set point


Control signal:

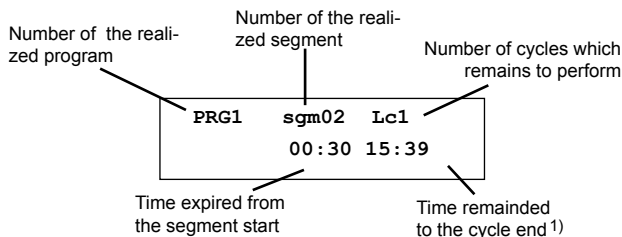
H - heating, C- cooling

Control deviation

PRG1      $\underline{1}$      PID1  
H=50.0%     E= 0.6

**Fig.8.2. Loop screen with control acc. to the program of the set point value**



Further information about the realized program are on the screen (named: *program screen*) which is displayed after pressing the .





**Fig.8.3. Exemplary program screen**

1) The time which remained to the cycle end is displayed in units chosen in the **TimeUnit** parameter. If a part of hours (minutes) exceed the value 99, then only the component with the letter h (m), is displayed, e.g. 102 h means, that 102 hours remained to the cycle end and the part with minutes is invisible.

Meaning of messages in the program status field Table 5

Status field	Explanation
	Program in progress
<b>STOP</b>	The control is turned off, e.g. after finishing the program or by the operator through  and  . push-buttons. In this mode, the control output is turned off.
<b>E&gt;H1b</b>	The control deviation is higher than the admissible in the given object
<b>EVH1b</b>	The program is held the logic input with function <b>HoldbackPrg</b>
<b>rsH1b</b>	The program is locked by the interface


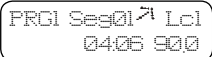


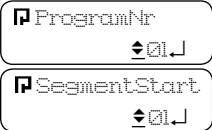


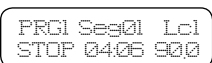

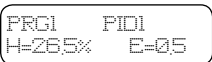
During the program realization, beside the number of performed segment, a symbol is displayed which informs how the set point changes in the segment:

-  - when the set point increases
-  - when the set point decreases
- - when the set point does not change

The control of the program is carried out from the keyboard, i.e. start of the program from the indicated segment, stop of the program and its restart, is carried out when the *program screen* is active (see diagram 8.2.)

### Push-button functions during the program-following control

Table 6

Push -button(s)	Function	Exemplary screen
	Calls the program screen.	
 and 	Choice of the program number to realize the starting segment and setting the program in motion.	
 and 	Stops or restarts the program.	
	Return to the basic screen.	

The program lockout means the stop of set point counting till the moment of lockout reason removal.

During the active lockout, the annunciator P is flickering,

The control is carried out acc. to the last counted set point and the segment time is stopped.

## Control - program-following control

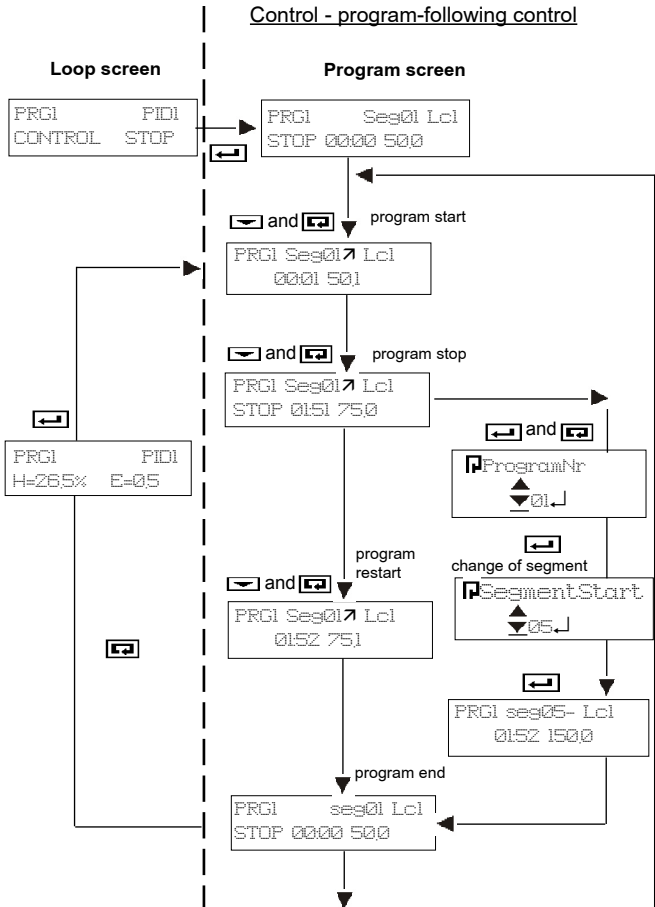


Fig.8.4. Example of program operation control

## 9. SPECIAL FUNCTIONS

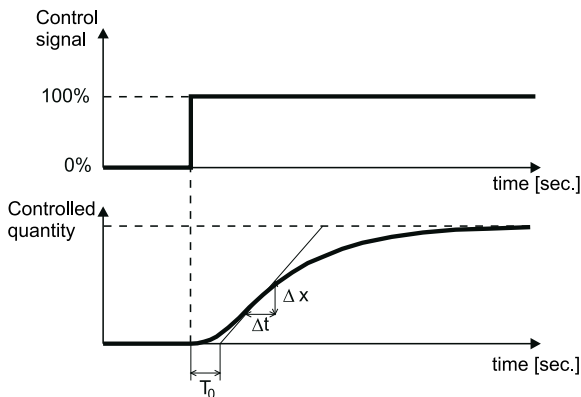
One can call several functions from the **Special Functions** menu: selection of settings, resistance measurement of two-wire lines, return to factory settings, and loop switching.

### 9.1. SELECTION OF PID CONTROLLER SETTING

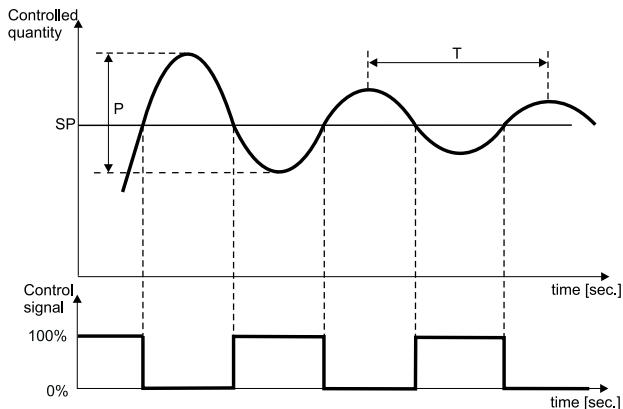
During the loop configuration, one must define which of the two algorithms of setting selection (**In start-up** or **At setpoint**) can be applied for this loop or lockout the function calling, writing the **No apply** value in the **Autotuning** parameter. When the control according to the program is chosen, then the **Autotuning** parameter can accept only the **None** value.

The **Autotuning** parameter set on **In start-up** means that PID parameters will be calculated on the base of the inert object characteristic - Fig. 9.1.

The **Autotuning** parameter set on **At setpoint** means that PID parameters will be calculated on the base of oscillations around the set point - fig. 9.2.



**Fig.9.1. Selection of PID parameters through the object identification method**




**Fig.9.2. Selection of PID parameters through the oscillation method**

The special function **PID Autotuning** produces the algorithm of the automatic selection of PID parameters, chosen during the loop configuration. One must give, in which loop the function will be called (**Loop1** or **Loop2**). During the active autotuning, the diode A is lighting.

After finishing the function, new PID settings are stored in the assigned PID set to the loop. The controller returns to the control mode with the **New Settings!** Message - The diode A is flickering. The pressure of any optional key restores the screen of automatic control.

The setting selection procedure can be broken without the PID setting calculation, when one of the reasons described in the table 7 occurs.

Message	Reason
Choice broken from the configuration	For the chosen kind of control (heating-cooling, valve control or programmed control) the algorithm of automatic setting choice is not realized.
Choice broken. Too small deviation	At the function start, the set point is too near to the measured value i.e., for the identification algorithm, the control deviation is less than 15 % of the control range in the loop ( <b>Ct1HighLimit</b> - <b>Ct1LowLimit</b> ), and for the oscillation algorithm, the control deviation is less than 1% of the control range.
Choice broken Instability	For the identification algorithm, the controlled quantity is unstable (changes higher than 1% of the control range per minute) during over 2 hours.
Choice broken Lack of reaction	The accessible heating power is too small to reach the set point - For the identification algorithm: if after 50 minutes the controlled value has not increased at least by 3% of the control range.
Choice broken from the keyboard	The  .push-button has been pressed.
Choice broken Error on the input	An error occurs on the input

In each of above case, the controller returns to the automatic control and displays a suitable message till the pressure of any push-button.

If for any reason, one cannot use proposed algorithms, one must choose parameters applying following principles:

**free answer  
of the object**

- decrease the proportional band, the integration time-constant and the differentiation time-constant,

**overshoots**

- increase the proportional band and the differentiation time-constant,

**oscillations**

- increase the proportional band and the integration time-constant, decrease the differentiation time-constant,

**instability**


- increase the integration time-constant.

Symptoms of a wrong selection of PID settings and recommended correction.

Run of the controlled quantity	Algorithms of the controller operation			
	P	PD	PI	PID
	$xP\uparrow$	$xP\uparrow\ td\downarrow$	$xP\uparrow$	$xP\uparrow\ td\downarrow$
	$xP\uparrow$	$xP\uparrow\ td\uparrow$	$xP\uparrow\ ti\uparrow$	$xP\uparrow\ td\uparrow\ ti\uparrow$
		$xP\downarrow\ td\downarrow$		$xP\downarrow\ td\downarrow\ ti\downarrow$
	$xP\downarrow$	$xP\downarrow$	$ti\downarrow$	$xP\downarrow\ ti\downarrow$

## 9.2. RESISTANCE MEASUREMENT OF A TWO-WIRE LINE .

In controllers with RTD sensors connected by a two-wire line, one must introduce the line resistance value or take advantage of the special **LeadResistance** function.


- ◆ Call the **LeadResistance** function
- ◆ Choose the **AnalogInput1** or **AnalogInput 2**
- ◆ Short sensor terminals on the chosen input; the resistance value is measured on the lower display,
- ◆ After the value stabilization, accepted it by the  push-button

A resistance of wires higher than 20  $\Omega$  will not be accepted by the controller, and the **Resist.Over High** message appears on the character display, till the pressure of any push-button. If question marks are displayed instead of the resistance, that means the resistance is higher than 420  $\Omega$ , sensor terminals have not been probably shorted.

In case when the chosen input is the control input in one of the loop, then the control in this loop will be turned off during the line resistance measurement.

Moreover, if this loop is displayed on the higher display, then dashes appear on the display of controlled quantity.

## 9.3. RETURN TO FACTORY SETTINGS.

One can restore the factory settings after calling the special function **Factory Settings** and accept the **Reset** command by the  push-button.

### **Caution!**

The function does not change the type of input signals and units for temperature inputs.

## 9.4. AUTOMATIC SWITCHING OF LOOPS

One can switch alternately the display of data on, in both loops on LED displays and annunciators, when the controller operates in the configuration mode. The switching frequency is defined in the **LoopTime** parameter in the range from 3 to 20 seconds. The write of a number in the range 0 to 2, means that the alternate display is turned off - information about the lately chosen channel is displayed.

## 9.5. CHANGE OF USER'S LANGUAGE

The **Language** parameter enables the change of language which names of menu and parameters are displayed in, from Polish into English or inversely.

## 10. MESSAGES ON DISPLAYS

Sometimes, during the controller operation or configuration, messages appear on displays, which inform about the way of loop operation, emergency situation or conflict in the loop confirmation way. A list of such messages is presented in the table 8.

Messages

Table 8

Message	Reason	Procedure
<b>Error</b> Error in the input	Exceeding of the measuring range down and up. Short-circuit in the sensor circuit or break in the sensor circuit.	<ul style="list-style-type: none"><li>- Check if the type of chosen sensor is compatible with the connected one.</li><li>- Check if input signal values are situated in the appropriate range.</li><li>- check if a short-circuit or break has not occurred in the sensor circuit.</li></ul>
<b>CONTROL STOP!</b>	The automatic control has been turned off	
<b>NO CONTROL!</b>	None of control outputs has been connected to the loop	
<b>SP out of range</b>	The set point assigned to the loop is not situated in the loop control range	Change the set point or the control range of the loop
<b>No heating output</b>	For the chosen type of control in the loop, there is no output with <b>Heating</b> function	Check and if need be, correct the assigned outputs and their functions ( <b>Input/Output</b> menu)
<b>No cooling output</b>	For the chosen type of control in the loop, there is no output with <b>Cooling</b> function	Check and if need be, correct the assigned outputs and their functions ( <b>Input/Output</b> menu)
<b>Lockout of changes !</b>	One of the logic input has been defined as lockout of parameter changes and is shorted.	
<b>Incorrect code of changes</b>	The given security code does not correspond to the previously set.	

# 11. TECHNICAL DATA

## Input signals and measuring ranges

Table 9

Input	Signal source	Symbol	Measurement error in % of the range	Measuring range
Main input 1 and 2	Pt100 acc. EN 60751+A2	Pt100	0.1	-200...850°C -328.0...1562.0°F
	Pt500 acc. EN 60751+A2	Pt500	0.1	-200...850°C -328.0...1562.0°F
	Pt1000 acc. EN 60751+A2	Pt1000	0.1	-200...850°C -328.0...1562.0°F
	Ni100/1.617	Ni100	0.2	-60...180°C -76.0...356.0°F
	Cu100/1.426	Cu100	0.2	-50...180°C -58.0...356.0°F
	Termocouple FeCu-Ni	J	0.2	-200...1200°C -328.0...2192.0°F
	Termocouple Cu-CuNi	T	0.2	-100...400°C -148.0...752.0°F
	Termocouple NiCr-NiAl	K	0.1	-200...1370°C -328.0...2498.0°F
	Termocouple PtRh10-Pt	S	0.2	-50...1760°C -58.0...3200.0°F
	Termocouple PtRh13-Pt	R	0.2	-50...1760°C -58.0...3200.0°F
	Termocouple PtRh30-PtRh16	B	0.3 <sup>1)</sup>	300...1820°C 572.0...3308.0°F
	Termocouple NiCr-CuNi	E	0.1	-200...1000°C -328.0...1832.0°F
	Termocouple NiCrSi-NiSi	N	0.1	-150...1300°C -238.0...2372.0°F
	Linear current 0...20 mA	0...20 mA	0.05	0...20 mA
	Linear current 4...20 mA	4...20 mA	0.05	4...20 mA
	Linear voltage 0...10 V <sup>2)</sup>	0...10 V	0.05	0...10 V
	Linear voltage 0...5 V <sup>2)</sup>	0...5 V	0.05	0...5 V
Linear voltage 1...5 V <sup>2)</sup>	1...5 V	0.05	1...5 V	
Auxiliary current input	Linear current 0...20 mA	0...20 mA	0.05	0...20 mA
	Linear current 4...20 mA	4...20 mA	0.05	4...20 mA
Auxiliary voltage or potentiometric input	Linear voltage 0...10 V	0...10 V	0.05	0...10 V
	Linear voltage 0...5 V	0...5 V	0.05	0...5 V
	Linear voltage 1...5 V	1...5 V	0.05	1...5 V
	Potentiometric transmitter 0...100 Ω	0...100 Ω	0.1	0...100 Ω
	Potentiometric transmitter 0...1000 Ω	0...1000 Ω	0.1	0...1000 Ω

<sup>1)</sup> Error in the range: 500...1820°C (932.0...3308.0°F)

<sup>2)</sup> Source resistance: < 10 kΩ



## Reference and rated working conditions

- ◆ supply voltage 85...253 V a.c/d.c  
or 18...30 V d.c
- ◆ supply voltage frequency 40...400 Hz
- ◆ ambient temperature 5...23...40°C (41...73.4...104°F)
- ◆ relative humidity < 85% (without condensation)
- ◆ external magnetic field < 400 A/m
- ◆ working position any
- ◆ resistance of conductors connecting the resistance thermometer with the controller < 10 Ω /wire

**Maximal power consumption** < 9 VA

**Weight** 400 g

## Protection grade ensured through the case acc. EN60529

- ◆ from the frontal side IP 40
- ◆ from terminals IP 20

## Additional errors in rated operating conditions caused by:

- ◆ compensation of conductor resistance changes in a-3-wire line < 0.1% of the measuring range
- ◆ compensation of thermocouple reference junction temperature changes < 2°C (3.6°F)
- ◆ change of ambient temperature ≤ 0.1% of the measuring range/10K

## Security requirements acc. EN61010-1

- ◆ installation category - III,
- ◆ pollution degree - 2.
- ◆ maximal phase-to-earth working voltage:
  - for supplying circuits and relay outputs: 300 V
  - for input circuits, continuous outputs, transistor outputs and the interface: 50 V

## Electromagnetic compatibility

- ◆ immunity EN 61000-6-2
- ◆ emission EN 61000-6-4

## 12. ORDERING CODES

Table 11

Dual loop controller RE19		X	X	X	X	X	X
<b>Version</b>	for standard control .....	S					
	for valve control.....	V					
	for programmed control.....	P					
	on order* .....	X					
<b>Auxiliary input</b>	without input.....	0					
	current 0/4...20 mA.....	1					
	voltage 0...10 V, 0...5 V, 1...5 V potentiometric transmitter 0...100 Ω						
	potentiometric transmitter 0...1000 Ω ...	2					
	on order* .....	X					
<b>Outputs</b>	4 relays .....	1					
	4 OC transistors .....	2					
	1 transistors 0/15 V + 3 relays .....	3					
	2 transistors 0/15 V + 2 relays .....	4					
	1 continuous + 3 relays .....	5					
	1 continuous + 3 OC transistors.....	6					
	2 continuous + 2 relays .....	7					
	2 continuous + 2 OC transistors.....	8					
	1 continuous +1 transistors 0/15V+2 relays .....	9					
on order* .....	X						
<b>RS-485 Interface</b>	without interface .....	0					
	with MODBUS protocol .....	1					
<b>Supply voltage</b>	85...253 V a.c./d.c. ....	1					
	18...30 V d.c.....	2					
<b>Additional testing requirements</b>	without extra requirements.....	8					
	with an extra quality inspection certificate.....	7					
	according customer's requirements ** .....	X					

\* The version code is established by the manufacturer

\*\* After agreement with the manufacturer

### Ordering example:

The **RE19 - S 1 5 1 1 8** code means:

- S** - version for standard control
- 1** - auxiliary input: 0/4...20 mA,
- 5** - with 1 continuous output and three relays
- 1** - with RS-485 interface
- 1** - supply voltage: 85...253 V a.c./d.c.
- 8** - without extra testing requirements

### **13. MAINTENANCE AND WARRANTY**

The RE19 controller does not require any periodical maintenance.

In case of some incorrect operations:

**1. After the dispatch date within the period state in the warranty card:**

One should take the instrument down from the installation and return it to the Manufacturer's Quality Control Dept.

If the instrument has been used in compliance with the instructions, the Manufacturer guarantees to repair it free of charge.

**2. After the warranty period:**

One should send the instrument to repair it in an authorized service workshop.

Spare parts are available for the period of ten years from the date of purchase.

**Our policy is one of continuous improvement and we reserve the right to make changes in design and specifications of any products as engineering advances or necessity requires and revise the above specification without notice.**



## **SALES PROGRAM**

- DIGITAL AND BARGRAPH PANEL METERS
- MEASURING TRANSDUCERS
- ANALOG PANEL METERS (DIN INSTRUMENTS)
- DIGITAL CLAMP-ON METERS
- INDUSTRIAL PROCESS CONTROLLERS
- CHART AND PAPERLESS RECORDERS
- POWER CONTROL UNITS AND SOLIDE-STATE RELAYS
- ELECTRONIC WATT-HOUR METERS
- INTEGRATION ELEMENTS OF MEASURING NETWORKS
- LARGE-SIZE ALPHANUMERICAL DISPLAY PANELS
- ACCESSORIES FOR MEASURING INSTRUMENTS (SHUNTS)
- CUSTOM-MADE PRODUCTS

## **MEASUREMENT CONTROL RECORDING**

### ***WE ALSO OFFER OUR SERVICES IN THE PRODUCTION OF:***

- ALUMINIUM ALLOY PRESSURE CASTINGS
- PRECISION ENGINEERING AND THERMOPLASTICS PARTS
- SMT ASSEMBLY SERVICES
- MOUNTING OF ELECTRONIC DEVICES

### ***QUALITY PROCEDURES:***

***According to ISO 9001 and ISO 14001 international requirements.***

All our instruments have CE mark.

For more information, please write to or phone our Export Department



**Lubuskie Zakłady Aparatów Elektrycznych LUMEL S.A.**

ul. Sulechowska 1, 65-022 Zielona Góra, Poland

Tel.: (48-68) 329 51 00 (exchange)

Fax: (48-68) 329 51 01

e-mail: [lumel@lumel.com.pl](mailto:lumel@lumel.com.pl)

<http://www.lumel.com.pl>

**Export Department:**

Tel.: (48-68) 329 53 02

Fax: (48-68) 325 40 91

e-mail: [export@lumel.com.pl](mailto:export@lumel.com.pl)