



**CONTROLLER  
WITH UNIVERSAL  
INPUT AND 1 OUTPUT  
RE22 TYPE**



**USER'S MANUAL**





## **CONTENTS**

<b>1. APPLICATION</b> .....	<b>5</b>
<b>2. CONTROLLER SET</b> .....	<b>6</b>
<b>3. CONTROLLER PREPARATION TO WORK</b> .....	<b>6</b>
3.1. Safety .....	6
3.2. Controller installation in the panel .....	7
3.3. Electrical connection .....	8
3.4. Installation recommendations .....	9
<b>4. STARTING TO WORK</b> .....	<b>10</b>
<b>5. PROGRAMMING OF CONTROLLER PARAMETERS</b> .....	<b>11</b>
5.1. Scheme of the controller menu .....	11
5.2. Setting change .....	13
5.3. List of parameters .....	14
<b>6. INPUTS AND OUTPUTS OF THE CONTROLLER</b> .....	<b>17</b>
6.1. Measuring input .....	17
6.2. Output .....	18
<b>7. CONTROL</b> .....	<b>19</b>
7.1. ON -OFF control .....	19
7.2. PID control .....	19
<b>8. ADDITIONAL FUNCTIONS</b> .....	<b>20</b>
8.1. Display of the control signal .....	20
8.2. Manual control .....	20
8.3. Controller reaction after sensor damage .....	20
8.4. Rate of the set point change .....	21
8.5. Manufacturer's settings .....	21
<b>9. SELECTION OF PID PARAMETER SETTINGS</b> .....	<b>21</b>
9.1. Auto-tune function .....	21
9.2. Manual selection of PID parameter settings .....	23
<b>10. SIGNALLING OF ERRORS</b> .....	<b>25</b>
<b>11. TECHNICAL DATA</b> .....	<b>26</b>
<b>12. ORDER CODES</b> .....	<b>29</b>
<b>13. MAINTENANCE AND GUARANTEE</b> .....	<b>30</b>



# 1. APPLICATION

The RE22 controller co-operates directly with resistance thermometers (RTD) and thermocouples (TC) or quantity converters into a standard signal.

It is destined for temperature control in plastics, food, glass, ceramics, dehydration industries and everywhere when it is necessary to stabilize temperature changes.

The measuring input is universal for resistance thermometers and thermocouple sensors or for linear standard signals.

The relay output, with a make-brake configuration ( with NOC or NCC contacts) allows to the direct control of low power objects.

The manual control and soft-start are also possible.

One can protect the controller against the undesirable change of parameters by means of a password.

The auto-tuning function permits to select the PID setting in order to a quick output signal adaptation to object parameters.

## 2. CONTROLLER SET

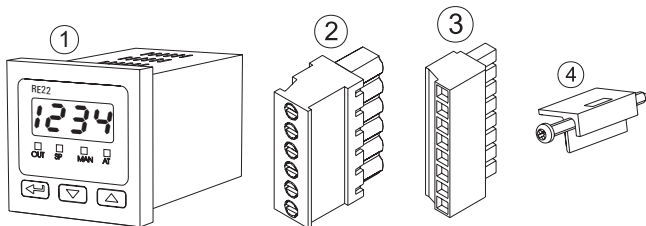

The controller set is composed of:

- |                                      |       |
|--------------------------------------|-------|
| 1. controller .....                  | 1 pc  |
| 2. plug with 6 screw terminals ..... | 1 pc  |
| 3. plug with 8 screw terminals ..... | 1 pc  |
| 4. holder to fix in the panel .....  | 2 pcs |
| 5. user's manual .....               | 1 pc  |
| 6. quick start card .....            | 1 pc  |
| 7. guarantee card .....              | 1 pc  |

When unpacking the controller, please check whether the type and option code on the data plate correspond to the order.

## 3. CONTROLLER PREPARATION TO WORK

### 3.1. Safety

The RE22 controller fulfils requirements concerning the safety of automation measuring instruments acc. to the EN 61010-1 standard, requirements concerning the fastness against electromagnetic interference acc. to EN 61000-6-2 standard and emission of electromagnetic interference occurring in the industrial environment, acc. to the EN 61000-6-4 standard.

### 3.2. Controller installation in the panel

Fix the controller in the panel by means of two screw holders acc. to the fig.1. The hole in the panel should have  $45^{+0.6} \times 45^{+0.6}$  mm dimensions. The material thickness what the panel is made of cannot exceed 15 mm.

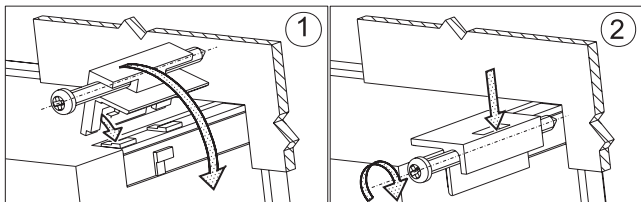

*Fig.1. Controller fixing.*

Controller overall dimensions are presented on the fig. 2.

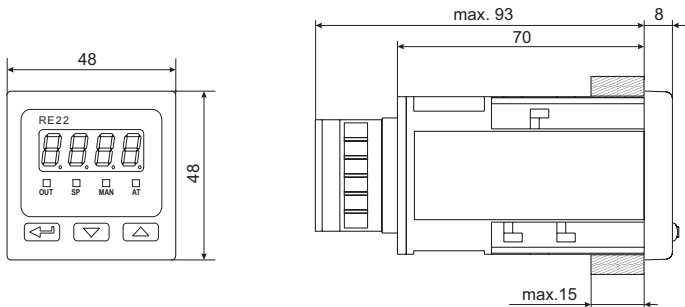

*Fig.2. View of controller connection strips.*

### 3.3. Electrical connections

Carry out electrical connections to terminal strips and next, insert strips into controller sockets.

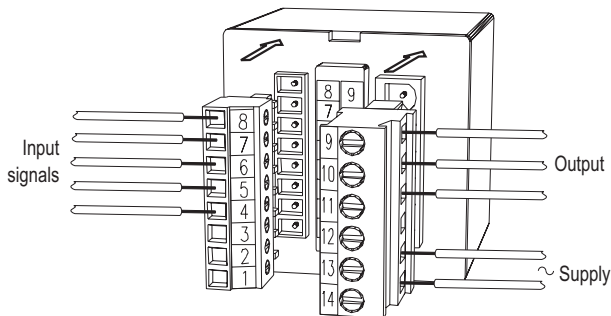

Fig.3. View of controller connection strips.

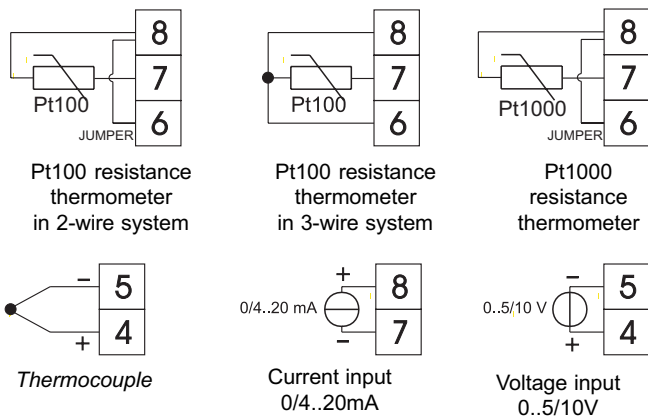
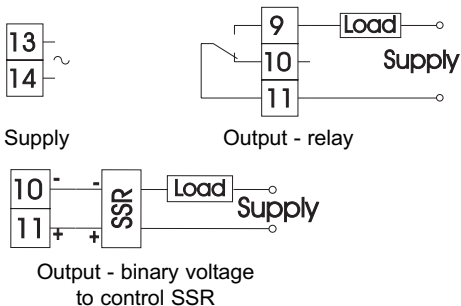

Fig.4. Connection of input signals.



*Fig.5. Connection of the supply and load circuit.*

When connecting the supply, one must remember that an automatic cut-off should be installed near the device, easily accessible for the operator and suitably marked.

### 3.4. Installation recommendations

The RE22 controller fulfils requirements concerning the fastness against electromagnetic interference occurring in the industrial environment acc. to obligatory standards.

**In order to obtain a full immunity of the controller against electromagnetic interference in an unknown environment interference level it is recommended to observe following principles:**

- do not supply the controller from the network near devices generating high impulse interference and do not use common earthing circuits with them,
- apply network filters,
- apply metallic shields in the shape of tubes or braided screens to conduct supplying wires,
- wires supplying the measuring signal should be twisted in pairs, and for resistance thermometers in a 3-wire connection, twisted from wires with the same length, cross-section and resistance, and led in a shield as above,

- all screens should be one side earthed, and led the nearest possible to the controller,
- apply the general principle that wires leading different signals should be led the farthest possible between them (not less than 30 cm), and their crossing executed at a right angle.

## 4. STARTING TO WORK

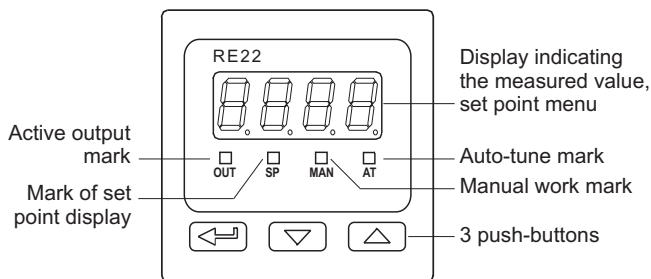

*Fig.6. View of the controller frontal plate.*

After connecting to the power, the controller carries out the display test and displays the  $RE22$  inscription, the program version, and next, displays the measured value.

A character message can appear on the display, informing about abnormalities. (table 4).

The algorithm of ON-OFF control with a 2°C hysteresis is set by the manufacturer.

## Change of the set point

The way to change the set point during the normal work is shown on the fig. 7. The change limitation is set by SPL and SPH parameters.

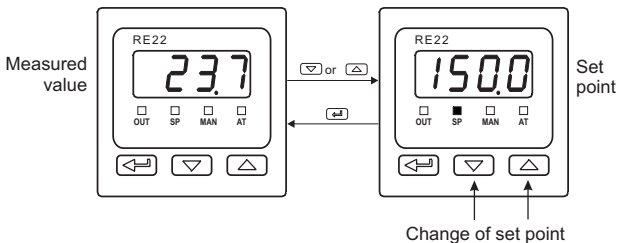

Fig.7. Change of the set point during the normal work..

## 5. PROGRAMMING OF CONTROL PARAMETERS

### 5.1. Scheme of the controller menu

After pressing and holding the push-button during at least 2 sec., it is possible to program parameters. The transition between parameters is carried out by means of and push-buttons. The return to the normal working mode follows after the simultaneous pressure of and push-buttons, or automatically, after 30 sec from the last push-button pressure.

Some parameters can be invisible - it depends on the current controller configuration.

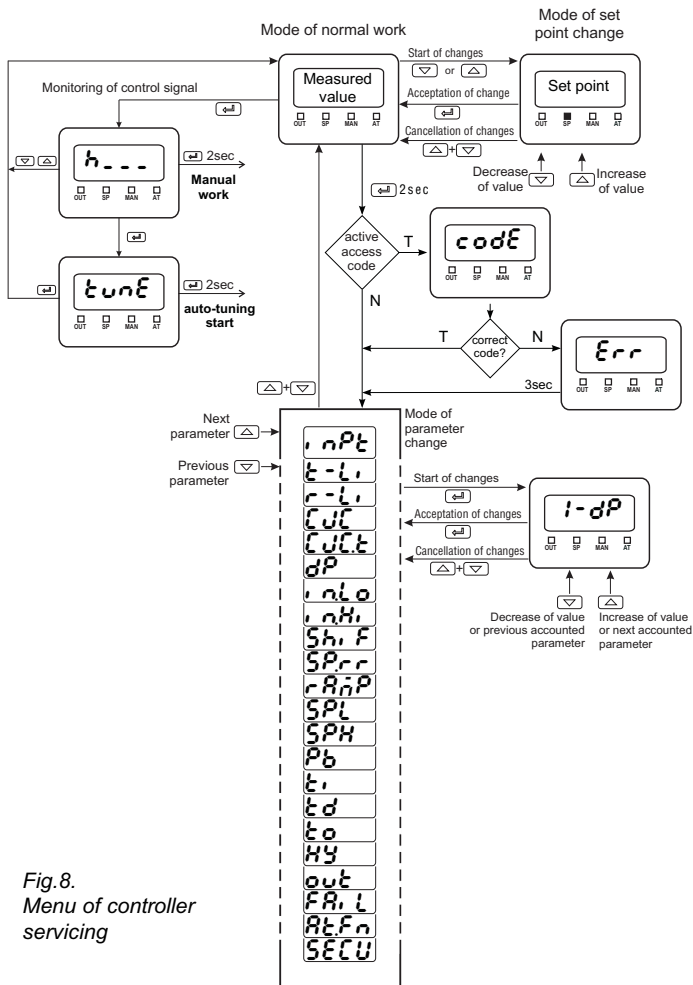







Fig.8.  
Menu of controller  
servicing

The access to parameters can be protected by a code. If the safety code is set (parameter *SECU* is higher than zero), one must give it. If the value will not be given or will be erroneous, the inscription *Err* appears on displays, and the user will be only able to monitor parameter values.

## 5.2. Setting change

The change of parameter setting begins after pressing the  push-button. By means of  and  push-buttons we make the choice of the setting, and by the  push-button we accept it. The cancellation of the change follows after the simultaneous pressure of  and  push-buttons or automatically after 30 sec. from the last push-button pressure. The way of setting change is presented on the fig.9.

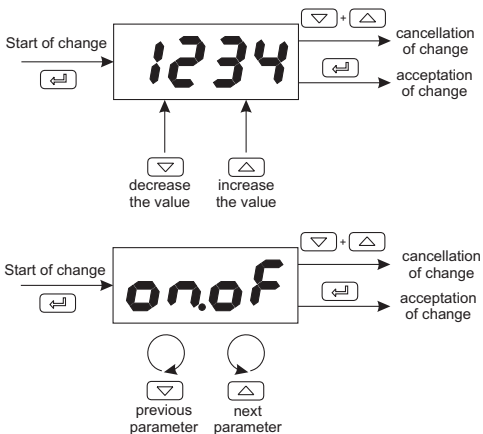

Fig.9. Setting change of numerical and textual parameters.

### 5.3. List of parameters

The list of controller parameters is presented in the table 1.

Table 1

parameter symbol	parameter description	range of parameter changes	
		sensor	linear signal
$i_n P_t$	kind of input (description in table 2)	$[P_t \ 1]$ : Pt100 $P_t \ 10$ : Pt1000 $t - J$ : thermocouple of J type $t - t$ : thermocouple of T type $t - K$ : thermocouple of K type $t - S$ : thermocouple of S type $t - R$ : thermocouple of R type $t - B$ : thermocouple of B type $t - E$ : thermocouple of E type $t - N$ : thermocouple of N type $t - L$ : thermocouple of L type	$0 - 20$ : lin. current 0-20 mA $[4 - 20]$ : lin. current 4-20 mA $0 - 5$ : lin. voltage 0-5 V $0 - 10$ : lin. voltage 0-10 V
$t - L, 1$	line type (2-wire or 3-wire line) <sup>1)</sup>	$[2 - P]$ : 2-wire line $3 - P$ : 3-wire line	_____
$r - L, 1$	resistance of 2-wire line, for Pt100 sensor	0.0...20.0 $\Omega$ [0.0]	_____
$CUC$	way of cold ends compensation for thermocouples <sup>2)</sup>	$[RUCO]$ : automatic compensation $HRnd$ : manual compensation	_____
$CUCt$	temperature of cold ends during the manual compensation [ $^{\circ}C \times 10$ ] <sup>2)</sup>	0.0...50.0 $^{\circ}C$ [0.0]	_____
$dP$	position of the decimal point	$0 - dP$ : without decimal place $1 - dP$ : 1 decimal place	$0 - dP$ : without decimal place $1 - dP$ : 1 decimal place $2 - dP$ : 2 decimal place

symbol parametru	opis parametru	zakres zmian parametru	
		czujniki	sygnały liniowe
<b>INLO</b>	indication for the lower threshold of analog input	_____	-1999...9999 <sup>3)</sup> [0.0]
<b>INH1</b>	indication for the upper threshold of analog input	_____	-1999...9999 <sup>3)</sup> [100.0]
<b>SHF</b>	shift of the measurand value	-99.9...99.9 °C [0.0]	-999...999 <sup>3)</sup> [0.0]
<b>SPCR</b>	accretion rate of the set point	0...999.9 / unit [0.0]	0...999.9 / jedn. [0.0]
<b>RAIP</b>	time unit for the accretion rate of the set point	[n, n]: minute Hour: hour	[n, n]: minute Hour: hour
<b>SPL</b>	lower setting limitation of the set point	acc. to table 2 <sup>3)</sup> [-199.0]	INLO...INH1 <sup>3)</sup> [0.0]
<b>SPH</b>	upper setting limitation of the set point	acc. to table 2 <sup>3)</sup> [850.0]	INLO...INH1 <sup>3)</sup> [100.0]
<b>Pb</b>	proportional band	0...999.9 °C [0.0]	0...9999 <sup>3)</sup> [0.0]

symbol parametru	opis parametru	zakres zmian parametru	
		czujniki	sygnały liniowe
<b>t<sub>i</sub></b>	integration time-constant <sup>4)</sup>	0...9999 s [0]	0...9999 s [0]
<b>t<sub>d</sub></b>	differentiation time-constant <sup>4)</sup>	0...999.9 s [0.0]	0...999.9 s [0.0]
<b>t<sub>o</sub></b>	pulse repetition period of the output <sup>4)</sup>	0.5...99.9 s [20.0]	0.5...99.9 s [20.0]
<b>H<sub>y</sub></b>	hysteresis <sup>5)</sup>	0.2...99,9 [2.0]	0.2...999 <sup>3)</sup> [2.0]
<b>out</b>	output configuration	<b>d</b> : cooling signal [ <b>r</b> ]: heating signal	
<b>FR<sub>L</sub></b>	control signal of the output for proportional control in case of sensor damage <sup>4)</sup>	0...100.0 % [0.0]	0...100.0 % [0.0]
<b>At.Fn</b>	auto-tuning function	<b>off</b> : locked [on]: unlocked	
<b>SECU</b>	safety code <sup>6)</sup>	0...9999 [0]	0...9999 [0]

1) The parameter is visible only for Pt100 resistance thermometer.

2) The parameter is visible only for the execution with thermocouple inputs.

3) Resolution what the given parameter is shown with, depends on the **dP** parameter - position of the decimal point.

4) The parameter is invisible at ON-OFF control.

5) The parameter is visible at ON-OFF control

6) The parameter is hidden in the parameter review mode only for readout.  
(for readout only)

Symbol	Input / sensor	Minimum	Maximum
Pt 1	Resistance thermometer Pt100	-199°C	850°C
Pt 10	Resistance thermometer Pt1000	-199°C	850°C
t - J	Thermocouple J type	-100°C	1200°C
t - t	Thermocouple T type	-100°C	400°C
t - K	Thermocouple K type	-100°C	1372°C
t - S	Thermocouple S type	0°C	1767°C
t - R	Thermocouple R type	0°C	1767°C
t - B	Thermocouple B type	0°C	1820°C
t - E	Thermocouple E type	-100°C	999°C
t - N	Thermocouple N type	-100°C	1300°C
t - L	Thermocouple L type	-100°C	800°C
0-20	Linear current 0-20 mA	-1999	9999
4-20	Linear current 4-20 mA	-1999	9999
0-5	Linear voltage 0-5 V	-1999	9999
0-10	Linear voltage 0-10 V	-1999	9999

## 6. INPUTS AND OUTPUTS OF THE CONTROLLER

### 6.1. Measuring input

The controller has one measuring input, which on can connect different types of sensors or standard signals to.

The choice of the input signal is performed by the  $\rho t$  parameter. For different types of inputs, depending on the option code, one must give additional parameters.

For the Pt100 resistance thermometer, one must choose the kind of connection. In a three-wire connection, the line resistance compensation goes on automatically.

In a two-wire connection, one can give additionally the line resistance, for thermocouples, one must give the way of temperature compensation of cold ends - automatic or manual, and at manual compensation - the temperature of cold ends.

For linear inputs, one must give indications for the lower and upper threshold of the analog input. The position of the decimal point is an additional parameter, the parameter  $dP$ .

For temperature sensors, it defines whether the measured temperature and the set point temperature is to be shown with a place after the decimal point.

For linear inputs, it defines the resolution which the measured value and values of some parameters are shown with.

The correction of measured value indications is carried out by the  $Sh, F$  parameter.

## 6.2. Output

The controller has one measuring input with a switch over contact. It is possible to select the ON-OFF control or proportional (PID) control at the output. For the proportional control, one must additionally set the pulse repetition period. The pulse repetition period is the time which expires between successive switches of the output during the proportional control. The length of the pulse repetition period must be chosen depending on dynamic properties of the object and suitably to the output device for quick-acting processes, it is recommended to apply SSR relays. The relay output is used to control contactors in slow-acting processes.

The use of a high pulse repetition period to control quick-acting processes can give unwanted effects in the shape of oscillations. Theoretically, smaller the pulse repetition period better the control is, but for the relay output it should be as high as possible in order to extend the relay life.

Recommendations concerning the pulse repetition period. Table 3

Output	Pulse repetition period is	Load
electromagnetic relay	recommended >20 s min. 10 s	2 A/230 V a.c. or contactor
	min. 5 s	1 A/230 V a.c.
transistor output	1...3 s	Semi-conductor relay (SSR)

## 7. CONTROL

### 7.1. ON-OFF control

To select the ON-OFF control, one must set the parameter  $Pb=0$ . Next, set the hysteresis value -  $HY$ . The action of the output on heating (fig. 10.) is set by the parameter  $out=i, nu$ , and on cooling, by the parameter  $out=d, r$ .

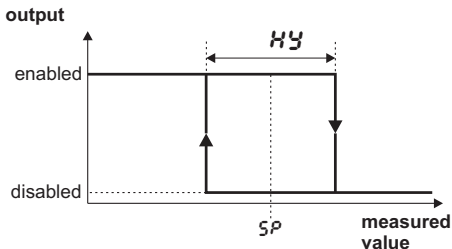





Fig.10. Operation way of the heating type output

### 7.2. PID control

The choice of PID control, or also PI, PD or P control, consists on a suitable setting of parameter values - proportional band ( $Pb$ ), integrating element ( $t_i$ ) and differentiating element ( $t_d$ ). The switching of the giving element off, consists on setting the parameter on zero. The operation way of the heating type output is chosen by setting the parameter  $out=i, nu$ , and the cooling type by setting the parameter  $out=d, r$ . The successive parameter to set is the pulse repetition period of the output ( $t_o$ ).

## 8. ADDITIONAL FUNCTIONS





### 8.1. Display of the control signal

After pressing the  push-button, the value of the control signal (0...100%) appears on the display. On the first digit, the mark  $h$  is displayed. The return to the normal operation follows after the simultaneous pressure of  and  push-buttons.

### 8.2. Manual control

The manual control gives the possibility, among other things, to identify and test the object or control it after the sensor damage.

The entry into the manual control mode follows after holding down the  push-button when displaying the control signal. The manual control is signaled by the diode pulsation, marked as MAN. The controller breaks the automatic control and begins the manual control of the output. The value of the control signal is displayed on the lower display, preceded by the symbol  $h$ .

 and  push-buttons serve to change the control signal, which is displayed on the lower display. The exit to the normal working mode follows after the simultaneous pressure of  and  push-buttons.

After setting the ON-OFF control on the output 1 (parameter PB = 0), one can set the control signal on 0% or 100% of power, however when the PB parameter is greater than zero, the control signal can be set on any value from the 0...100% range.

### 8.3. Controller reaction (response) after the sensor damage

It is possible to configure the output state after the sensor damage.



- at output configuration for proportional control (PB > 0) the control signal value is defined by the  $F R, L$  parameter,
- at output configuration for the ON-OFF control, the output will be disabled - at output operation as heating, or enabled - at output operation as cooling.

## 8.4. Rate of the set point change - soft-start

The limitation of the temperature accretion rate is performed through the gradually change of the set point. This function is activated after switching the controller supply on and during the change of the set point. This function allows to reach in a gentle way the achievement from the current temperature to the set point. One should write the accretion value to the  $SPr$  parameter and the time unit to the  $rRnP$  parameter.

An accretion value equal to zero means, that the soft-start is disabled.

## 8.5. Manufacturer's settings

One can restore manufacturer's settings during the supply switching on by holding down  and  push-buttons till the moment when the inscription  $FAb$  appears on the upper display.

# 9. SELECTION OF PID PARAMETER SETTINGS

## 9.1. Auto-tuning

The controller has the function of the automatic PID setting choice. These settings ensure the optimal control in the majority of cases.

To start the auto-tuning, one must transit to the  $tunE$  parameter (acc. to the fig.8) and hold down the  push-button during at least 2 sec. If the proportional band is equal zero or the  $RtFn$  parameter is set on  $oFF$ , there will not be possible to start the auto-tuning.

The flickering upper display informs about the activity of the auto-tuning function. The duration of the auto-tuning function depends on object dynamic properties and can last maximally 10 hours. During the auto-tuning, or directly after, overshoots can occur and therefore, one must set a smaller set point, if it is possible.

The auto-tuning is composed of following stages:

- switching the control signal off, and stabilization of the object temperature (from 2 minutes till 3 hours),
- switching the control signal (100%) on, and determination of the object characteristic (maximally 10 hours),
- calculation of PID settings and their storage in the non-volatile memory,
- switching the PID control on with new settings.

The auto-tuning process may not start or be interrupted without the PID control if:

- the set point is too near to the measured value, i.e. the control deviation is smaller than 6.25% of the range,
- the time of the preliminary object stabilization or the admissible auto-tuning duration time will be overrun,
- a controller supply decay will occur,
- the  push-button has been pressed,
- calculated parameter values are beyond the range.

In such cases, the control with previous user's settings will start.

## 9.2. Manual selection of PID parameter settings

### Method of response to a unitary jump

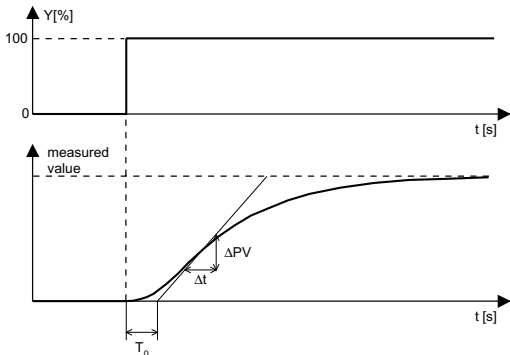

Fig.11. Selection of settings by the method of response to a unitary jump.

One must read out the delay time  $T_0$  and the maximal temperature accretion rate from the object characteristic presenting the controlled value in the function of time, from the dependence:

$$V_{\max} = \frac{\Delta PV_{\max}}{\Delta t}$$

Calculate PID settings acc. to following formulas:

$$Pb = 1.1 \cdot V_{\max} \cdot T_0 \quad - \text{proportional band}$$

$$ti = 2.4 \cdot T_0 \quad - \text{integration time constant}$$

$$td = 0.4 \cdot T_0 \quad - \text{differentiation time constant}$$

### Oscillation method around the set point

Set the ON-OFF control with a minimal hysteresis. Set the set point on a normal work level (or on a lower one, if overshoots would cause damages) and normal load conditions.

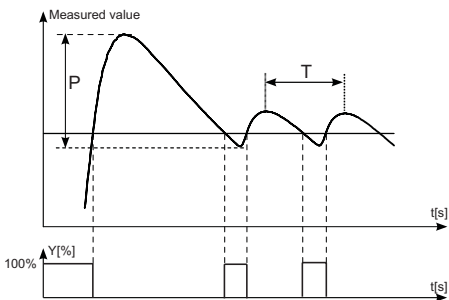

*Fig.12. Selection of settings by the oscillation method.*

Calculate controller settings acc. to given formulas:

$$P_b = P$$

$$t_i = T$$

$$t_d = 0.25 * T$$

### **Correction of PID settings**

Since PID parameters interact between them, one must introduce changes only of one parameter.

The best is to choose parameters changing the value into a twice greater or twice smaller one.

During changes, one should be guided by following principles:

- a) Slow jump answer:
  - decrease the proportional band,
  - decrease the integration and differentiation time.
- b) Over-regulations:
  - increase the proportional band,
  - increase the differentiation time.
- c) Oscillations:
  - increase the proportional band,
  - increase the integration time,
  - decrease the differentiation time.
- d) Instability:
  - increase the integration time.

## 10. SIGNALLING OF ERRORS

Character messages

Table 4

Error code (upper display)	Reason	Procedure
<i>LErr</i>	Exceeding of the measuring range downwards or short-circuit occurring in the sensor circuit	Check if the type of chosen sensor is in compliance with the connected one. Check if values of input signals are situated in the appropriate range. If so, check whether there is no short-circuit in the sensor circuit.
<i>HErr</i>	Exceeding of the measuring range upwards or break in the sensor circuit	Check if the type of chosen sensor is in compliance with the connected one. Check if values of input signals are situated in the appropriate range. If so, check whether there is no short-circuit in the sensor circuit.
<i>AtEr</i>	The auto-tuning has not been finished successfully	Check reasons of breaking the tuning process in auto-tuning point
<i>ErAd</i>	Discalibrated input	Connect again the controller supply and if it cannot help, contact the nearest authorized service shop.

## 11. TECHNICAL DATA

Input signals and measuring ranges for sensor inputs.

Table 5

Sensor type	Standard	Notation	Range	Symbol on the display
Pt100	EN 60751+A2	Pt100	-199...850°C	$Pt\ 1$
Pt1000	EN 60751+A2	Pt1000	-199...850°C	$Pt\ 10$
Fe-CuNi	EN 60584-1	J	-100...1200°C	$t - J$
Cu-CuNi	EN 60584-1	T	-100...400°C	$t - t$
NiCr-NiAl	EN 60584-1	K	-100...1372°C	$t - K$
PtRh10-Pt	EN 60584-1	S	0...1767°C	$t - S$
PtRh13-Pt	EN 60584-1	R	0...1767°C	$t - r$
PtRh30-PtRh6	EN 60584-1	B	0...1820°C*	$t - b$
NiCr-CuNi	EN 60584-1	E	-100...999°C	$t - E$
NiCrSi-NiSi	EN 60584-1	N	-100...1300°C	$t - n$
chromel-kopel	GOST R 8.585	L	-100...800°C	$t - l$

\* The measurement error is defined for the range 0...1820°C

Input signals and measuring ranges for linear inputs

Table 6

Sensor type	Notation	Range	Symbol on the display
Linear current input	I	0...20 mA	$0 - 20$
Linear current input	I	4...20 mA	$4 - 20$
Linear voltage input	U	0...5 V	$0 - 5$
Linear voltage input	U	0...10 V	$0 - 10$

### Input signals:

- for sensor inputs acc. to table 5
- for linear inputs acc. to table 6

### Basic error of true value measurement:

- 0.2%, for RTD inputs,
- 0.3%, for TC inputs (0.5% - for B, R, S),
- 0.2% ± 1 digit, for linear inputs

**Measurement time:**

- for sensor inputs 0.33 s
- for linear inputs 0.16 s

**Input resistance:**

- for voltage input 150 k $\Omega$
- for current input 4  $\Omega$

**Detection of error in the measuring circuit:**

- thermocouple, Pt100, PT1000 overrunning of the measuring range
- 0...10 V over 11 V
- 0...5 V over 5,25 V
- 0...20 mA over 22 mA
- 4...20 mA under 1 mA and over 22 mA

**Control algorithm:**

P, PD, PI, PID,  
two-state with hysteresis

**Range of controller parameter settings:**

see table 1

**Kind of outputs:**

- relay switch over contact  
maximal load-carrying capacity:  
voltage: 250 V a.c., 150 V d.c.  
current: 5 A 250 V a.c., 5 A 30 V d.c.  
resistance load: 1250 VA, 150 W
- binary voltage (without isolation from the sensor side) voltage 5 V  
resistance limiting the current 66  $\Omega$  ;

**Way of output action:**

- reverse for heating
- direct for cooling

**Signalling:**

- output switching on
- display of set point
- manual control mode
- auto-tuning mode

**Rated service conditions:**

- supply voltage	230 V a.c. $\pm$ 10 % 110 V a.c. $\pm$ 10 % 24 V a.c. $\pm$ 10 %
- supply voltage frequency	50/60 Hz
- ambient temperature	0...23...50 °C
- storage temperature	-20...+70 °C
- relative air humidity	< 85 % (without condensation)
- external magnetic field	< 400 A/m
- preheating time	30 min
- work position	any
- resistance of wires connecting the resistance thermometer with the controller	< 20 $\Omega$

**Power consumption**

&lt; 3 VA

**Weight**

&lt; 0.25 kg

**IP protection ensured through the housing: acc. to EN 60529**

- from the frontal side	IP40
- from terminal side	IP20

**Additional errors in rated working conditions caused by:**

- compensation of the thermocouple cold junction	$\leq$ 2°C,
- ambient temperature change	$\leq$ 100% of the basic error value/10 K.

**Safety requirements acc. to EN 61010-1**

- installation category	III
- level of pollution	2
- maximal working voltage in relation to ground:	
- for supply circuit, outputs	300 V
- for input circuits	50 V

**Electromagnetic compatibility:**

- immunity acc. to EN 61000-6-2
- emission acc. to EN 61000-6-4

## 12. ORDER CODES

Coding way is given on the table 7.

Table 7

Controller RE22 -	X	X	X	XX	X
<b>Input</b>					
universal for thermocouples and RTD .....	1				
universal linear current 0/4..20 mA, and linear voltage 0...5/10 V .....	2				
on order .....	X				
<b>Output</b>					
relay .....	1				
binary 0/5 V to SSR control .....	2				
on order .....	X				
<b>Supply</b>					
230 V 50/60 Hz .....	1				
110 V 50/60 Hz .....	2				
24 V 50/60 Hz .....	3				
on order .....	X				
<b>Kind of option</b>					
standard .....				00	
custom-made* .....				XX	
<b>Additional</b>					
without a quality inspection certificate .....					8
with a quality inspection certificate .....					7
acc. to customer's agreement ** .....					X

\* The option code is established by the manufacturer.

\*\* After agreement with the manufacturer.

### Ordering example:

The code: **RE22-1-2-3-00-7** means:

- RE22** - controller with universal input + 1 output
- 1** - universal input for RTD and TE
  - 2** - binary output 0/5 V to SSR control
  - 3** - supply: 24 V a.c.
  - 00** - standard option
  - 7** - with an extra quality inspection certificate

## 13. MAINTENANCE AND GUARANTEE

The RE22 controller does not require any periodical maintenance.

In case of some incorrect operations:

### **1. After the dispatch date and in the period stated in the guarantee card**

One should return the instrument to the Manufacturer Quality Inspection Dept. If the instrument has been used in compliance with the instructions, the Manufacturer warrants to repair it free of charge. The disassembling of the housing causes the cancellation of the granted guarantee.

### **2. After the guarantee period:**

One should turn over the instrument to repair it in a certified service workshop. Spare parts are available for the period of five years from the date of purchase.

Our policy is one of continuous improvement and we reserve the right to make changes in design and specifications of any products as engineering advances or necessity requires and revise the above specifications without notice.



© LUMEL S.A., RE22-KZ1340/February 2007



Lubuskie Zakłady Aparatów Elektrycznych - LUMEL S.A.  
ul. Sulechowska 1, 65-022 Zielona Góra, Poland

Tel.: (48-68) 32 95 100 (exchange)

Fax: (48-68) 32 95 101

[www.lumel.com.pl](http://www.lumel.com.pl)

e-mail: [lumel@lumel.com.pl](mailto:lumel@lumel.com.pl)

Export Department:

Tel.: (48-68) 329 53 02 or 53 04

Fax: (48-68) 325 40 91

e-mail: [export@lumel.com.pl](mailto:export@lumel.com.pl)