

## Table of contents

---

		Page
Safety notes / Technical support		G2
-----		
Introduction		G3
-----		
Dimensions		G4
-----		
Technical data	Electrical Data	G8
	Mechanical Data	G9
	Operating conditions	G10
	Approvals	G10
	Sensor weight guide	G11
-----		
Options / Accessories		G12
-----		
Mounting		G14
-----		
Electrical installation	NB 3000 Nivobob	G16
	NB 9000 Remote Box	G20
-----		
Signal overview		G22
-----		
Programming NB 3000 Nivobob	Quickset menu	G24
	Output adjustment menu	G26
	Diagnostics menu	G29
	Communication menu	G31
	Modbus register	G32
-----		
Programming NB 9000 Remote Box		G34
-----		
Commissioning	Interface measurement	G36
-----		
Diagnostics	Maintenance	G37
	Failure	G39
-----		
Notes for use in Hazardous Locations		G40

Subject to technical change.  
 All dimensions in mm (inches).

All units in this information are CE-certified.

We assume no liability for typing errors.  
 Different variations to those specified are possible.  
 Please contact our technical consultants.

## Safety notes / Technical support

---

### Notes

- Installation, maintenance and commissioning must be carried out only by qualified technical personnel.
- The product must be used only in the manner outlined in this instruction manual.

Special attention must be paid to warnings and notes as follows:



#### WARNING

Relates to a caution symbol on the product and means, that a failure to observe the necessary precautions can result in death, serious injury and/or considerable material damage.

---



#### WARNING

Relates to a caution symbol on the product and means, that a failure to observe the necessary precautions can result in death, serious injury and/or considerable material damage.



This symbol is used, when there is no corresponding caution symbol on the product.

---

#### CAUTION

A failure to observe the necessary precautions can result in considerable material damage.

## Safety symbols

In manual and on product	Description
	CAUTION: refer to related documents (manual) for details.
	Earth (ground) Terminal
	Protective Conductor Terminal

## Technical support

Please contact your local supplier (see [www.uwt.de](http://www.uwt.de) for address). Otherwise you can contact:

UWT GmbH  
Westendstr. 5  
87488 Betzigau  
Germany

Tel. 0049 (0)831 57123-0  
Fax. 0049 (0)831 76879  
[info@uwt.de](mailto:info@uwt.de)  
[www.uwt.de](http://www.uwt.de)

## Introduction

---

The Nivobob® NB 3000 is an electromechanic level measuring instrument for continuous measuring of level or volumes in silos, hoppers or tanks.

## Applications

- Powder, granulate, small or coarse bulk goods
- Interface measurement (solids in water)

Applicable for industries such as

- Chemistry
- Food
- Cement
- Mining
- Plastics
- others

## Features

### Process

- Suitable for most types of bulk goods
- Independent of bulk material properties, such as:
  - Dielectricity and conductivity of the bulk good
  - Dusty atmosphere in the silo
  - Changing humidity inside the product
  - Products that tend to stick
- No mechanical load on the silo roof, the sensor weight just touches the surface of the material
- Very accurate measurement

### Service

- Simple installation and commissioning
- Measurement principle easy to understand
- Rope, tape and (optional) motor with increased service life
- Low maintenance

### Approvals

- Approval for use in Hazardous Locations  
ATEX II 1/2 D (zone 20/21) and FM Class. II, III Div.1 Gr. E–G

### Mechanic

- Measurement range upto 40m (133ft)
- 1 1/2" process connection possible
- Different sensor weights, suitable for every application
- Internal tape cleaner for difficult materials
- Window in lid and external start button (optional)
- Robust cast housing, ingress protection IP66

### Electronic

- Micro processor controlled measurement
- Remote Box for external programming, display of level and diagnose, start of measurement of up to 10 Nivobob units
- Comprehensive Diagnose possibilities
- Output 0/4–20mA / Modbus / Profibus DP / counting pulses
- Programmable relais (can be used as level limit switch outputs)
- Measurement start with external signal or integrated timer

## Function

The Nivobob® NB 3000 is mounted on the top of the silo. A sensor weight is driven down into the silo. It is mounted at the end of a rope or tape which is wound on a motor driven roller. Upon contact with bulk material, the motor changes the winding direction and the sensor weight is driven back to the upper stop position.

During downwards movement of the sensor weight the distance is electronically measured by the rotations of the internal rope / tape roller. The microcontroller converts the measured distance into an output signal, which is a volumetric signal based on the silo geometry. The output signal is updated, when the sensor weight touches the bulk material.

## Diagnostics

Comprehensive diagnostics possibilities are present:

- Measurement control is done by comparing the moved distance between up and downward movement and checking for discrepancy. In case of discrepancy, the sensor weight is pulled to the upper stop position to ensure, that the sensor weight is not inside the silo.
- Service interval after a certain amount of measurements and running time.
- Internal control of motor, motor driver electronic and smooth movement of rope / tape rollers.

Diagnostics is in accordance with NAMUR recommendation NE107.

## Dimensions

### Basic type

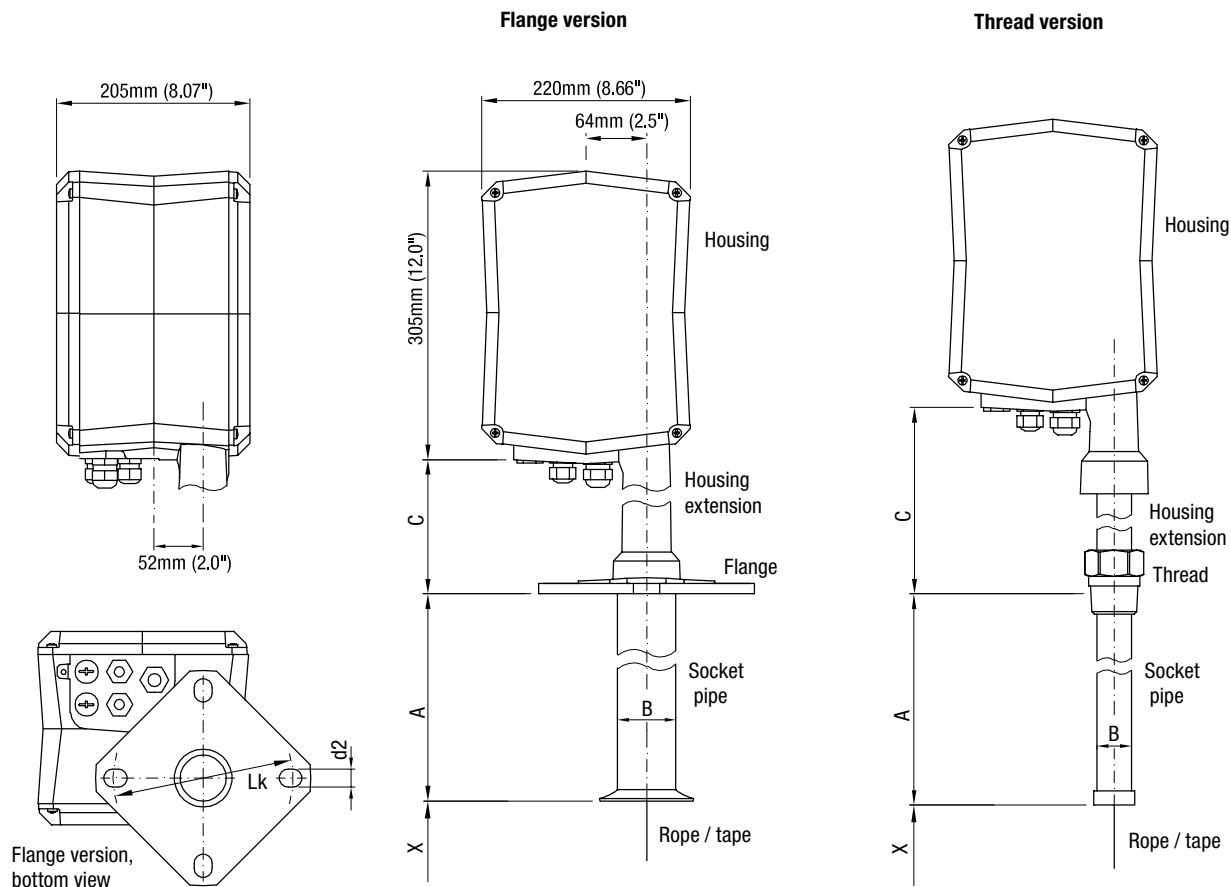

### Dimensions

<b>X</b> = Length to bottom of sensor weight (in upper stop position): see next page
---

<b>A</b> = Length of socket pipe
200mm (7.9") Optional 500mm (19.7") / 1000mm (39.4")

<b>B</b> = Diameter of socket pipe	
Rope version with Flange DN100 / 4"	ø60mm (2.36")
All other versions	ø40mm (1.57")

<b>C</b> = Housing extension		
Flange version	80°C / 150°C	95mm (3.74")
	250°C	340mm (13.4")
Thread version	80°C / 150°C	160mm (6.3")
	250°C	340mm (13.4")

<b>Rope</b>	ø1,25mm (0.49")
<b>Tape</b>	12x0.2mm (0.47x0.008")

Flanges	
fitting to: DN100 PN16 / 4" 150lbs	Lk = ø180-190.5mm (7.1-7.5") slot d2 = ø19mm (0.75")
fitting to: 2" / 3" 150lbs	Lk = ø120.7-152.4mm (4.75-6.0") slot d2 = ø19mm (0.75")

### Materials

<b>Housing outside</b>	Aluminium, powder coated
<b>Housing inside</b>	Aluminium
<b>Housing extension</b>	Aluminium, powder coated or 1.4305 (303)
<b>Flange</b>	80°C / 150°C: Aluminium, powder coated 250°C: 1.4305 (303)
<b>Thread</b>	1.4301 (304)
<b>Socket pipe</b>	Flange version 80°C / 150°C: Aluminium All other versions: 1.4301 (304)
<b>Rope</b>	1.4301 (304)
<b>Tape</b>	1.4310 (301)

**With option "Increased corrosion resistance":**  
 All metal parts in contact with the process are coated.  
 The rope is plastic coated with PA.  
 The internal bearings are made of stainless steel.

## Dimensions

### Options and Accessories

**Pos. 25**  
 Window in lid and  
 outside start button

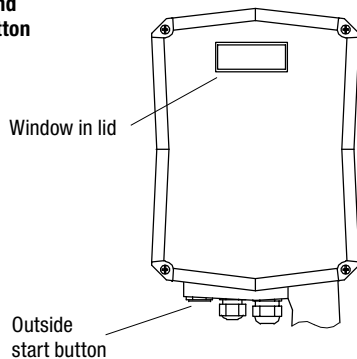

**Pos. 28**  
 Compressed air  
 connector

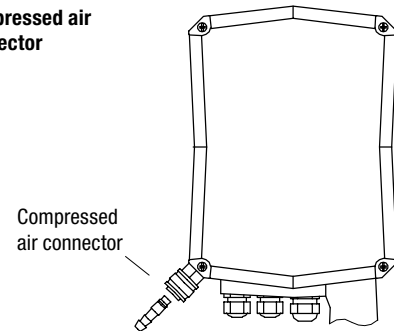

### Sensor weights

#### Solids measurement: Rope version

All weights ca. 1,0kg (2.2lbs)

##### PVC without pin

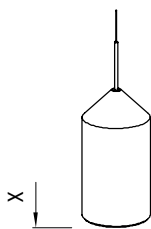

Ø81mm (3,2")  
 X = 137mm (5.4")  
 Material: PVC

##### PVC with pin

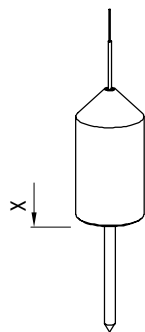

Ø81mm (3,2")  
 X = 137mm (5.4")  
 Pin: 130mm (5.1")  
 Material: PVC (pin POM)

##### Stainless steel

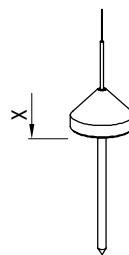

Version with  
 Flange DN100 / 4"  
 Ø75mm (3.0")  
 X = 25mm (1.0")  
 Pin: 130mm (5.1")

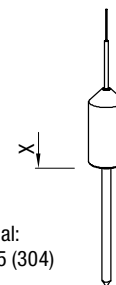

Material:  
 1.4305 (304)

All other versions  
 Ø42mm (Ø 1.65")  
 X = 81mm (3.19")  
 Pin: 130mm (5.1")

##### Claw

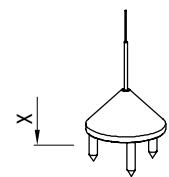

Ø95 (3.7")  
 X = 71mm (2.80")  
 Material: 1.4305 (304)

##### Folding cover

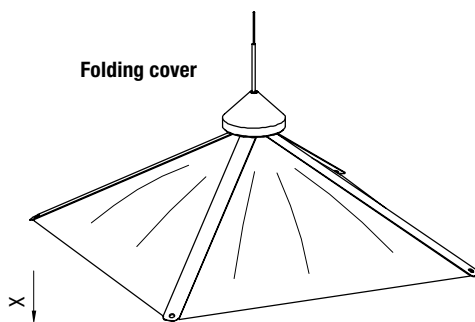

380x380mm (15x15")  
 X = 150mm (5.9")  
 Material: 1.4310 (301)  
 PA canvas

##### Spider

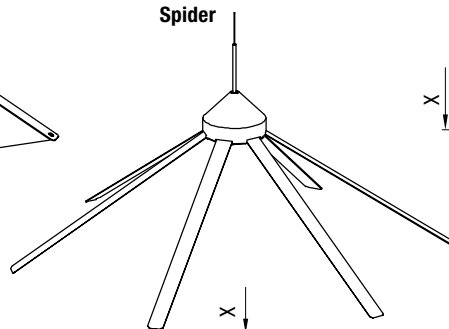

Ø600mm (23.6")  
 X = 160mm (6.3")  
 Material: 1.4301 (304) /  
 1.4310 (301)

##### Float

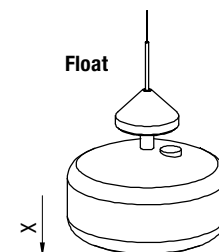

Ø190mm (7.5")  
 X = 175mm (6.9")  
 Material: Float PP,  
 Cone: 1.4305 (304)

##### Bag

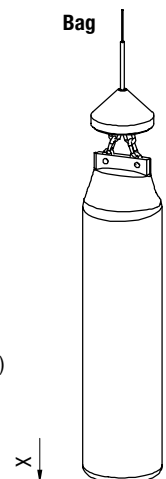

Ø95mm (3.7")  
 X = 460mm (18.1")  
 Material: PA canvas,  
 SS chain, alu cone

## Dimensions

### Solids measurement: Tape version

All weights ca. 2.1kg (4.6lbs)

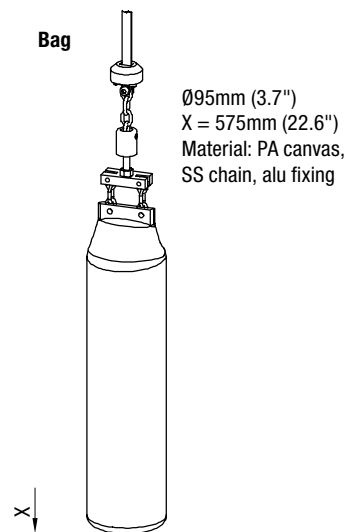
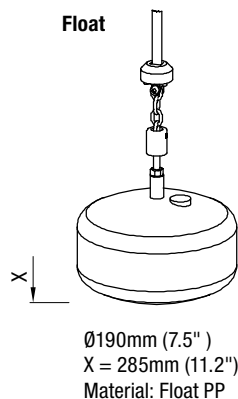
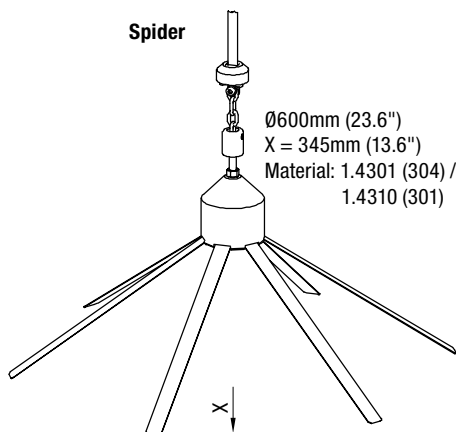
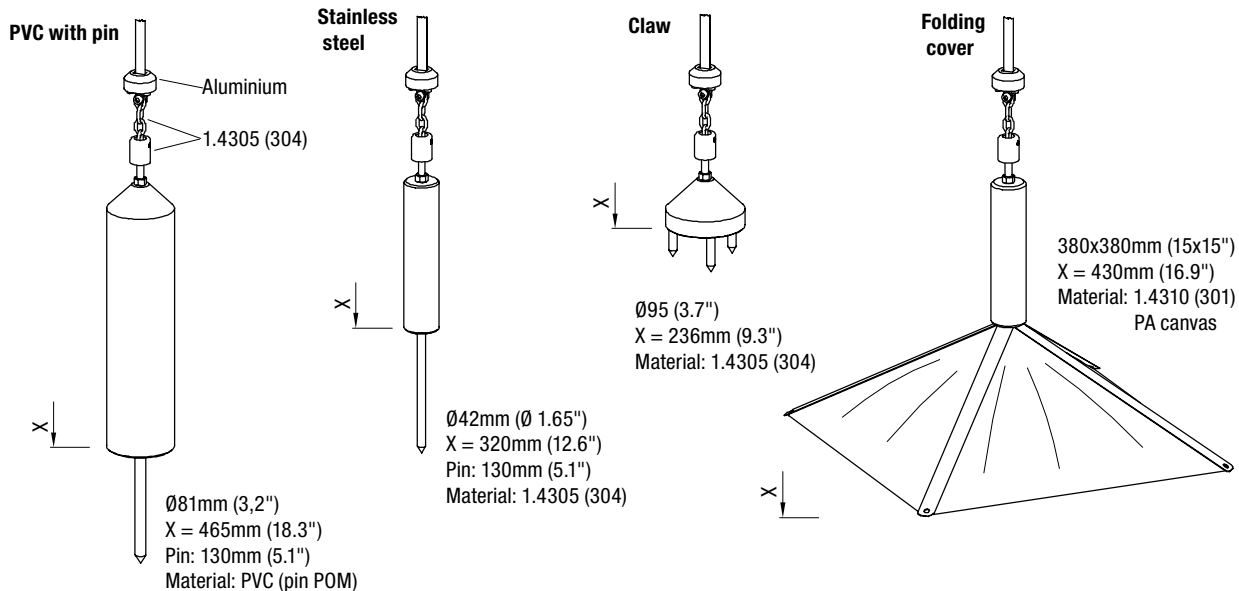

### Interface measurement: Rope version

Weight ca. 1,0kg (2.2lbs)

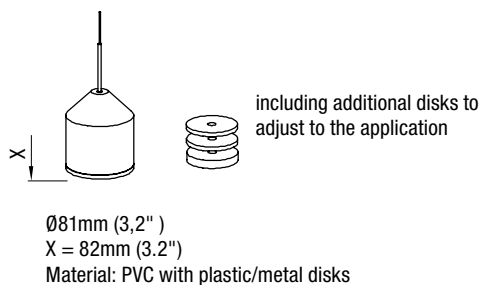

### Interface measurement: Tape version

Weight ca. 2.1kg (4.6lbs)

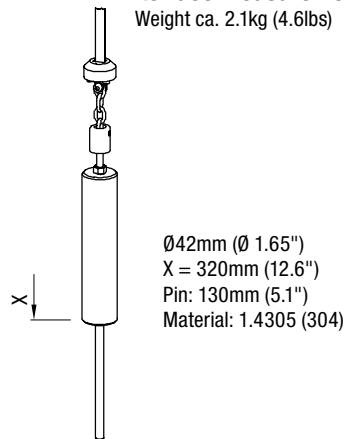

## Dimensions

### NB 9000 Remote Box

**NB 9000**  
 Panel mounting

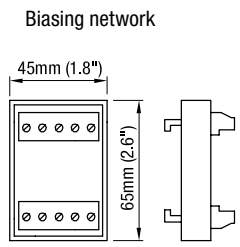
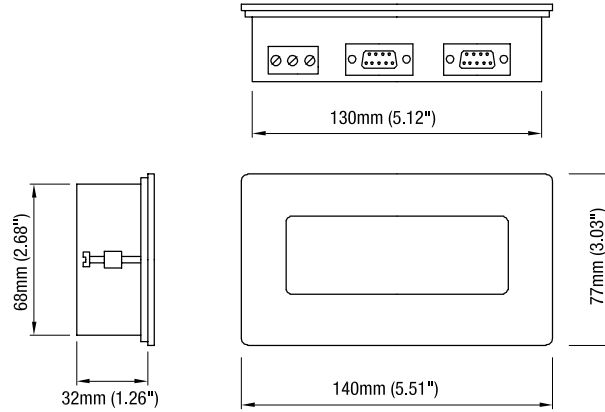

Mounting: DIN rail 35

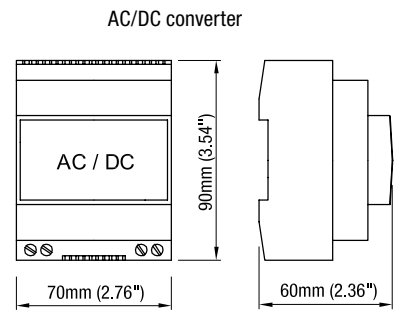
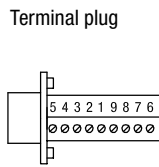

Mounting: DIN rail 35

**NB 9000**  
 Wall mounting

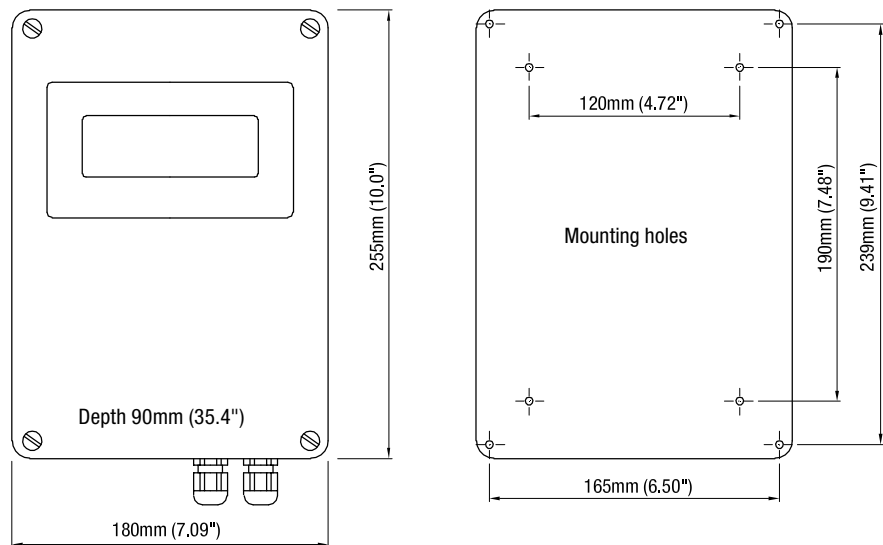

## Technical data

---

### Electrical data

**Power supply** AC version 98 .. 253V 50-60Hz  
 DC version 20 .. 28V  
 (voltages incl. 10% of EN 61010)

**Installed load** **AC version:** 150 VA (including internal heater (80W))

**DC version:**  
 One unit: 150W (with or without internal heater) \*  
 Further units which are connected to the same power supply:  
 25W per unit (without internal heater, motor off) \*\*  
 50W per unit (without internal heater, motor running)  
 80W per unit (with internal heater, supply voltage 20V DC)  
 100W per unit (with internal heater, supply voltage 24V DC)  
 120W per unit (with internal heater, supply voltage 28V DC)

\*Considers the max. motor traction which is needed in a failure condition. A failure condition is assumed for max. one unit at the same time.  
 \*\* This value can be considered, if the controlling PLC starts the measurement for max. one unit at the same time.

**Signal output:** Max. 500 Ohms (active, isolated) Linearity +/- 0,1mA  
**0/4-20mA**

**Signal output:** 4x Relay SPST:  
**Relay** max. 250V AC, 2A, 500VA non inductive

**Signal output:** Optocoupler  
**Electronic counting pulse** max. 30V DC, max. 25mA

**Communication:** Physical layer: RS 485 and Ground, isolated  
**Modbus RTU** Mode: RTU, Type: Slave  
 Device number range: 1 - 247 (selectable in menu), Baudrate: 1200 to 57600 Baud, Data bits: 8, Stop Bits: 1  
 Parity: None  
 Multi-drop configuration possible. Factory setting of adress is 100. Each unit which is connected to the network must be set to an individual adress.  
**Supported commands**  
 Reading: All diagnostics and parameters using command 03<sub>HEX</sub>: Read Holding Register  
 Writing: All parameters using command 06<sub>HEX</sub>: Write Single Register (not supported is command 10<sub>HEX</sub>: Write Multiple Register).

**Communication:** Physical layer: RS 485, isolated  
**Profibus DP** Type: Slave  
 Device number range: 0 - 126 (selectable in menu), Baudrate: 9.6 kbps to 12 Mbps  
 Available communication by GSD file, Read only (Sensor weight bottom to material (in mm))

Accuracy of measurement	Output	Setting	Accuracy
	Counting pulse	10cm (1/6ft) / pulse	1 pulse
		5cm (1/3 ft) / pulse	1 pulse
		2,5cm (1/10ft) / pulse	2 pulses
		1cm (1/20ft) / pulse	4 pulses
	0/4-20mA		1% of max. range
	Modbus RTU / Profibus		0.5% of max. range

**Display** LCD display: 2 line x 16 digit

**Indication light** Status by build in LED: Power On, Relais, Maintenance and Failure

## Technical data

<b>Memory</b>	Non-volatile (no backup battery required) > 10 years data retention
<b>Connection terminals</b>	0.14 .. 2.5mm <sup>2</sup> (AWG 26 .. 14)
<b>Cable entry</b>	According to selection: Screwed cable gland: 2x M20x1.5 and 1x M25x1.5 Blindplug: 2x M20x1.5 or Conduit ANSI B1.20.1: 1x NPT 3/4"+ 2x NPT 1/2" Blindplug: 2x NPT 1/2"
<b>Extension cables for Remote Box NB 9000 and Modbus</b>	Specifications see in chapter "Electrical installation" Suggested cable types see in chapter "Accessories"
<b>Extension cables for Profibus DP</b>	Use common recommended Profibus cables
<b>Isolation</b>	Power supply to all other outputs / inputs: AC version 2210 Vrms DC version: 1000 VDC Relay to relay: 2210 Vrms
<b>Protection class</b>	I

## Mechanical data

<b>Ingress protection</b>	IP 66, Type 4
<b>Process connection</b>	Threads: R 1 1/2" DIN 2999 tapered, NPT 1 1/2" or 3" ANSI B1.20.1 tapered Flanges: DN100 PN16 EN1092-1 (unit fits to this flange) 2" or 3" or 4" 150lbs ANSI B16.5 (unit fits to this flange)
<b>Colour</b>	Housing, Flange RAL 5010 (gentian blue) Lid RAL 9006 (aluminium silver)
<b>Material</b>	See detail specifications on page G4 - G6
<b>Measuring range</b>	Rope version max. 30m (100ft) Tape version max. 40m (133ft)
<b>Measuring speed</b>	Sensor weight speed in average: Standard version: ca. 0.25m/s (0.8ft/sec) Version with brushless motor: ca. 0.33m/s (1.0ft/sec)
<b>Weight</b>	Rope version with flange: ca. 11kg (24.2lbs) with thread: ca. 12kg (26.4lbs) Tape version with flange: ca. 12kg (26.4lbs) with thread: ca. 13kg (28.6lbs)
<b>Deviation of vertical mounting</b>	max. 2°
<b>Compressed air connector (Option)</b>	Quick coupling incl. opposite part, for hose diameter 9mm (0.35"), female at housing Max. operating pressure 0.2bar (2.9psi)

## Technical data

---

### Operating conditions

<b>Process overpressure</b>	-0.3 ..+0.3bar (-4.4 ..+4.4psi) -0.5 .. + 1.7 bar (-7.3 .. +25psi) optional for CE -0.5 .. + 1.1 bar (-7.3 .. +16psi) optional for FM		
<b>Process temperature</b>	-40°C ..+80 /150 / 250°C (-40 ..+176 / 302 / 482°F)		
<b>Ambient temperature</b>	-20°C .. +60°C (-4 .. +140°F) -40°C .. +60°C (-40 .. +140°F) -40°C .. +60°C (-40 .. +140°F) max. +40°C (104°F)	CE, FM General Purpose ATEX, FM Class II on request possible Version with Process temp. 150°C (302°F)	with internal heater
<b>Min. powder density</b>	see "Sensor weight guide" on next page		
<b>Minimum time between measuring starts</b>	measuring height 5m (16ft) -> 3min measuring height 10m (33ft) -> 6min measuring height 20m (66ft) -> 12min measuring height 30m (98ft) -> 18min measuring height 40m (131ft) -> 24min		
<b>Rope/tape operating time</b>	see page G38		
<b>Max. permitted tractive force</b>	Tape version:	with brushless motor: ca. 3000N standard motor: ca. 800N	
	Rope version:	with brushless motor: ca. 1000N standard motor: ca. 800N with increased corrosion resistance: ca. 700N	
<b>Relative humidity</b>	0-100%, suitable for outdoor		
<b>Altitude</b>	max. 2000m (6.562ft)		

## Approvals

**Hazardous Locations\*** ATEX II 1/2 D (zone 20/21)  
 FM Class. II, III Div.1 Gr. E-G

**General purpose \*** CE EN 61010-1  
 FM General purpose

**EMC** EN 61326 -A1 (industrial standard)

\* Depending on selected version in pricelist

## Technical data

### Sensor weight guide (solids measurement)

Sensor weight	Application				Note	Fits through mounting hole				
	* Material density g/l (lb/ft <sup>3</sup> )	Material consistence	Angle of repose	Max. process temp.		Thread		Flange		
						1 1/2"	3"	2"	3"	DN100 / 4"
PVC without pin	>300 (18)	granulate	flat	80°C (176°F)	Standard weight					•
PVC with pin	>300 (18)	granulate, powder	steep	80°C (176°F)	The pin penetrates into the material and avoids slipping or tilting of the sensor weight on the steep bulk surface.					•
Stainl. steel	>300 (18)	granulate, powder	flat, steep	250°C (482°F)	The pin penetrates into the material and avoids slipping or tilting of the sensor weight on the steep bulk surface.	•	•	•	•	•
Claw	>200 (12)	coarse (e.g. stones)	steep	250°C (482°F)	Avoids slipping or tilting on the steep bulk surface.					•
Folding cover	>20 (1.2)	light powder	flat, steep	80°C (176°F)	Big surface prevents the sensor weight from sinking into the material.	•	•	•	•	•
Spider	>40 (1.4)	light powder	flat, steep	250°C (482°F)	Big surface prevents the sensor weight from sinking into the material.					•
Bag	>300 (18)	granulate, powder	flat	80°C (176°F)	Prevents damage of the conveying screw. To be filled with bulk material.					•
Float	-	liquids only	-	80°C (176°F)	To be filled with material.					

\* The above mentioned data is a guideline and is valid for material which has settled after filling. During the filling the bulk density can change (e. g. for fluidised material).

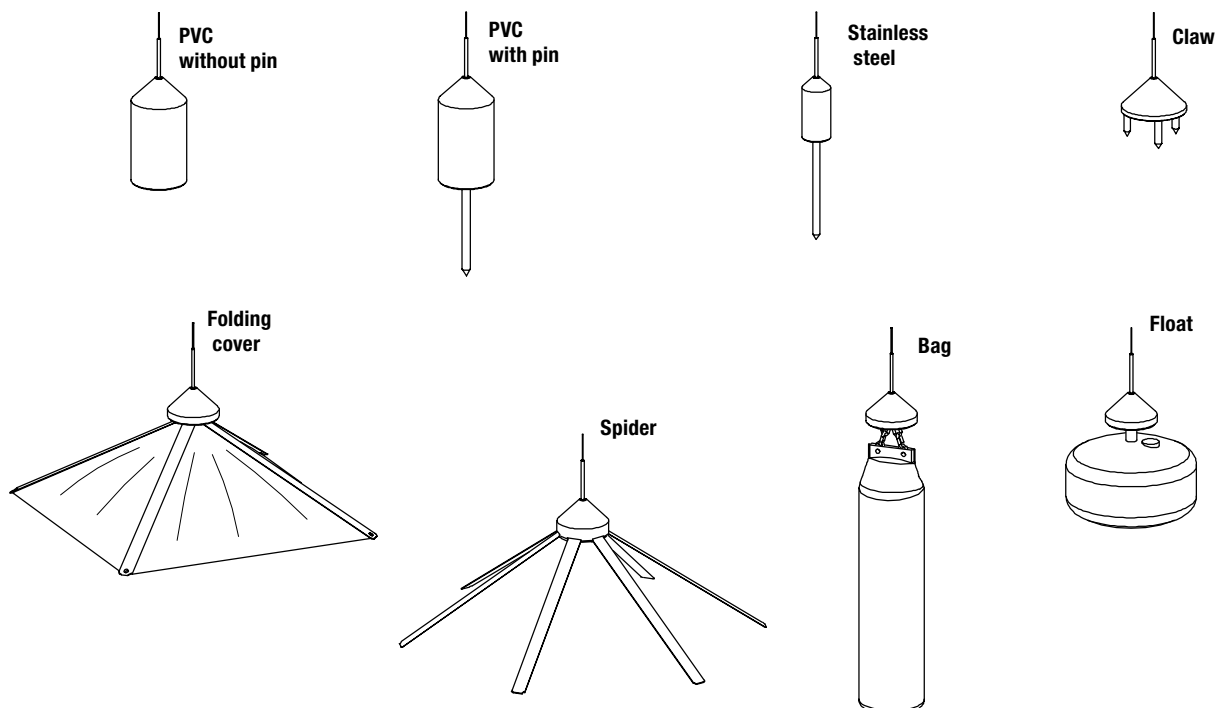

## Options / Accessories

### Options

**Window in lid and external start button**

Enables to see the display through the closed lid and to start a measurement without opening the lid.

Drawing see page G5

Material of the window: break-proof glass.

### Accessories

**NB 9000 Remote box (Panel mounting)**

Connecting up to 10 units with Modbus RTU network.

**Features:**

- Programming of the Nivobob units
- Display of level
- Start of measurement
- Display of diagnostics information

**Technical data:**

- NB 9000 works as a Modbus master
- Touchpanel
- Power supply: 24V DC +-10% 10W or 85 .. 264V +-0% 50-60Hz 10VA
- Ambient temperature: -0 .. +50°C (-32 .. +122°F)
- Ingress protection: IP65
- Installation only in Non-Hazardous areas permitted

**Included parts:**

For easy installation and proper functioning of the Modbus network

- **Biassing network (with Terminal resistor):**  
 Stabilizer for Modbus communication. Supports the needed biasing voltages to ensure a proper function in a network with long installed cables. Termination resistor is needed for the beginning of the Modbus network.
- **Terminal Plug**  
 Supplies screwing terminals for connection between NB 9000 panel and Biassing network
- **AC/DC converter**  
 Used, if AC power supply is selected

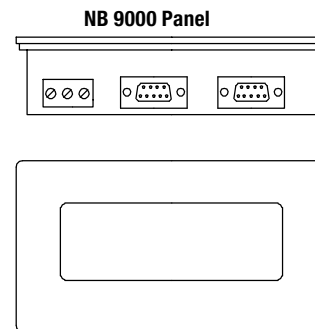

**Biassing network**

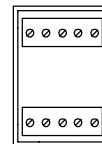

DIN rail 35 mounting

**Terminal Plug**

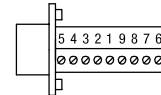

**AC/DC converter**

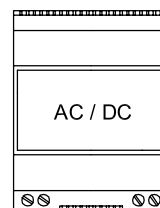

DIN rail 35 mounting

**NB 9000 Remote Box (Wall mounting)**

Implementation of NB 9000 panel in a wall mounted enclosure.

Material: PC (fibre glas reinforced)

Biassing network (with Termination resistor) implemented.  
 AC/DC converter (if AC power supply is selected) implemented.

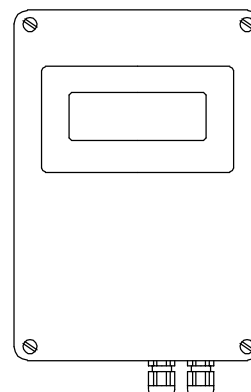

## Accessories

---

### Extension cables

- For connecting the Remote Box NB 9000
- For wiring a Modbus network
- Notes for choosing the right cable see chapter "Electrical Installation"
- It is generally recommended to protect PVC signal cables from UV influence by installing them in a pipe or hose.

#### Shielded cable

Functionality upto 50m

Cross section 2x 0,34mm<sup>2</sup> (AWG22), common shield

Capacitance 140nF/km (between wires) / 150nF/km (wire to shield)

-30°C (-22°F) to 70°C (158°F), PVC (LiYCY)

#### Twisted pair cable

Functionality upto 1000m

Twisted pair instrument cable, common shield

Cross section 2x 0,34mm<sup>2</sup> (AWG22)

Impedance 120 Ohms

Capacitance 40nF/km

-40°C (-40°F) to 75°C (167°F), PVC

#### Protection hose

for installation of extension cables in ATEX Zone 21 available

---

### Weather protection cover

If the unit is used outdoors, the use of the weather protection cover is recommended. It protects the device from all atmospheric influences such as

- rain water
- condensation water
- excessively high temperatures
- excessively low temperatures in winter

Material: PE, weather and temperature stable

For use in Hazardous Locations only permitted for Zone 22 or Division 2.

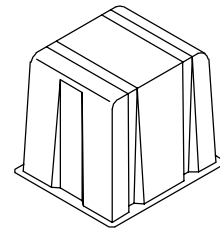

---

### Mounting set

Sealings, screws and washers for fixing the unit on a flange.

## Mounting

### ! General Safety Instructions

<b>Process pressure</b>	Improper installation may result in loss of process pressure.
<b>Chemical resistance against the medium</b>	Materials of construction are chosen based on their chemical compatibility (or inertness) for general purposes. For exposure to specific environments, check with chemical compatibility charts before installing.
<b>Mounting location</b>	The right mounting place is significant for a proper function. Observe mounting instructions.
<b>Vibrations</b>	Avoid mounting in applications with strong vibration. Use rubber mounts for absorption in case of light vibrations.

### ! Additional Safety Instructions for Hazardous Locations

<b>Installation regulations</b>	For devices to be used in Hazardous Locations the respective valid installation regulations must be observed.
<b>Sparks</b>	The installation has to be done in a way, that mechanical friction or impact does not cause sparks between the aluminium enclosure and steel.

## Mounting instructions

- Mounting position**
- The unit is mounted vertically on the silo. Max. deviation is 2°.
  - There must be at least 200mm (7.87") space for the sensor weight to move down in case of a full silo. Observe the bottom of the sensor weight at "upper stop position" (dimensions see page G4 - G6).
  - The socket pipe of the unit must protrude at least 50mm (2") into the silo. A version with longer socket pipe is available.
  - Proper movement of the sensor weight must be guaranteed, even if the sensor weight oscillates. Observe enough distance to the silo wall, stanchions and built-in fittings.

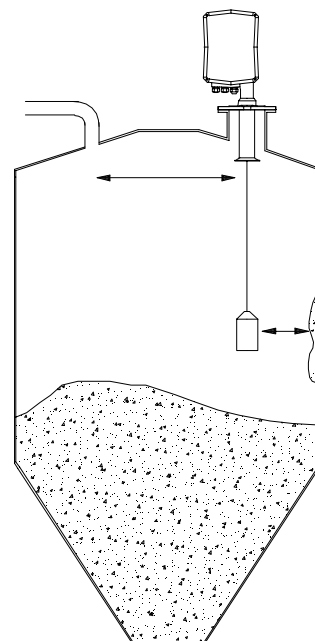
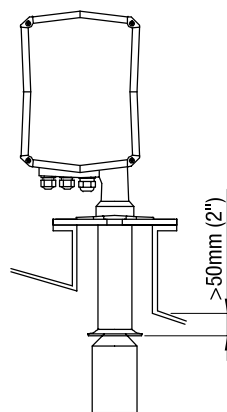

## Mounting

---

**Measurement during filling of the silo** Filling of the silo while measuring might cover the sensor weight with bulk material. Measurements during filling are possible, if there is enough distance to the infeed, so that no material can fall on the sensor weight.

---

**Sensor weight "Bag" and "Float"**

- The weights are filled with plastic granulate or sand. They shall be filled on site with bulk material or liquid, which is not critical if mixed with the material stored in the silo. Consider ageing of the material.
- When filling, observe the total weight of the sensor: rope version 1.0kg (2.2lbs), tape version 2.1kg (4.6lbs)

---

**Sealing**

- A rubber seal must be used to tighten the flange.
- Close both lids of the enclosure tightly.

---

**Sensor weight which does not fit through the mounting hole** The sensor weight must be removed before placing the unit on the silo. An inlet close to the fixing location and a hook is needed.

See installation manual for more details.

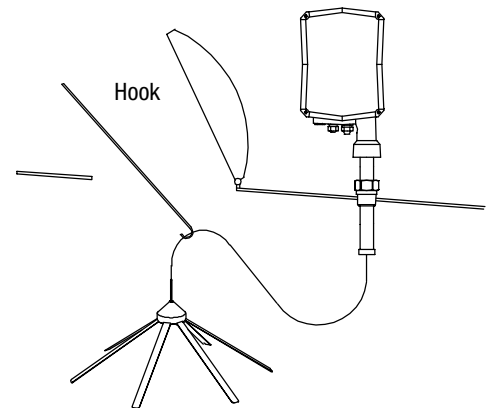

## Electrical installation

### ! General Safety Instructions

<b>Handling</b>	In case of improper handling or handling malpractice, the electric safety of the device cannot be guaranteed.
<b>Installation regulations</b>	The local regulations or VDE 0100 (Regulations of German Electrotechnical Engineers) must be observed.
<b>Fuse</b>	Use a fuse as stated in the connection diagrams.
<b>RCCB protection</b>	In case of a fault, the supply voltage must be automatically switched off by a RCCB protection switch to protect against indirect contact with dangerous voltages.
<b>Power supply switch</b>	A voltage disconnection switch must be provided near the device.
<b>Wiring diagram</b>	The electrical connections are made in accordance with the wiring diagram.
<b>Supply voltage</b>	Compare the supply voltage applied with the specifications given on the name plate before switching the device on.
<b>Cable gland</b>	Make sure that the screwed cable gland safely seals the cable and that it is tight (danger of water intrusion). Cable glands that are not used have to be sealed with a blanking element.
<b>Conduit system</b>	In case of using a conduit system (with NPT thread) instead of a cable gland the regulations of the country, where the unit is installed, must be observed. The conduit must have a tapered thread either NPT 1/2" or NPT 3/4" in accordance with the unit and ANSI B 1.20.1. Not used inlets must be closed tight with a metal blanking element.
<b>Field wiring cables</b>	All field wirings must have insulation suitable for at least 250V AC. The temperature rating must be at least 80°C (176°F).
<b>Relay protection</b>	Provide protection for relay contacts to protect the device against inductive load surges.
<b>Protection against static charging</b>	The housing of the unit must be grounded to avoid static charging of the unit. This is particularly important for applications with pneumatic conveying and non-metallic containers.

### ! Additional Safety Instructions for Hazardous Locations

#### External equipotential bonding terminal

Connect to equipotential bonding of the plant

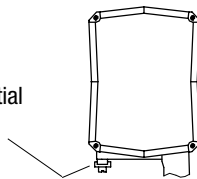

<b>Field wiring</b>	A strain relief must be provided for the field wiring cables, if the device is installed with the factory provided cable glands.
<b>Cable glands for ATEX Hazardous Locations</b>	The used entry devices and blanking elements must have an adequate type approval and a temperature range as defined in the technical data of the unit. In addition they shall be suitable for the conditions and correctly installed. Where applicable the provided original parts of the manufacturer must be used.
<b>Conduit system for ATEX and FM Hazardous Locations</b>	In addition the regulations of the country must be observed. The used flameproof seals and blanking elements must have an adequate type approval and a temperature range as defined in the technical data of the unit. In addition they shall be suitable for the conditions and correctly installed. Where applicable the provided original parts of the manufacturer must be used.
<b>Commissioning / opening the lid</b>	Commissioning only, when there are no dust deposits or swirls present.

## Electrical installation

### Terminal location

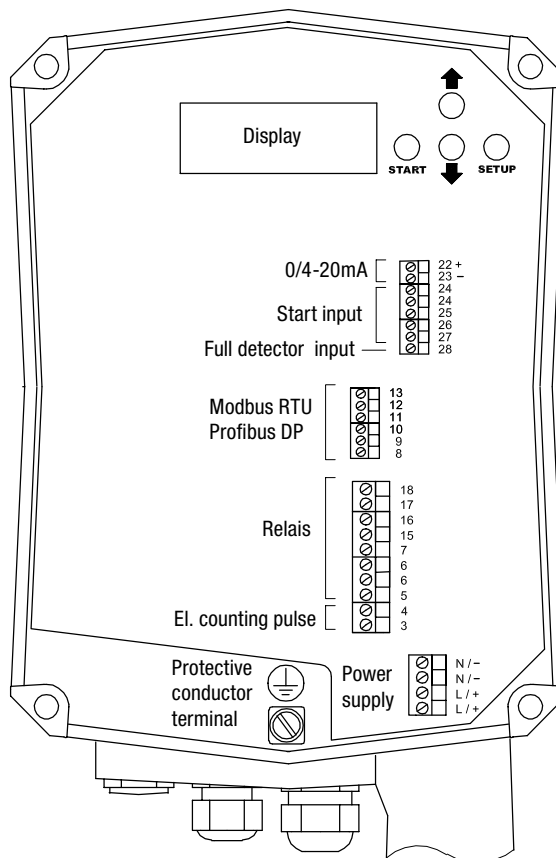

### NB 3000 - Power supply and Signal input /output

#### Power supply

##### AC version

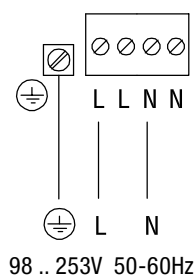

AC or DC supply  
depending on  
ordered version

##### DC version

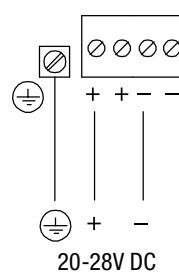

0.14 .. 2.5mm<sup>2</sup>  
(AWG 26 .. 14)

#### Signal input: Start of measurement

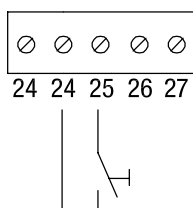

Start contact

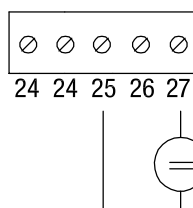

Start +24V

alternative

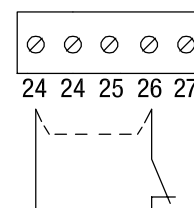

Measurement interruption in  
case of filling. If used, remove  
factory provided connection.

0.14 .. 2.5mm<sup>2</sup>  
(AWG 26 .. 14)

**Signal  
description:**  
See page G22

## Electrical installation

**Signal input:**  
**Full detector**

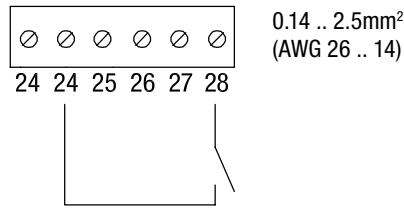

**Signal description:**  
 See page G22

**Signal output:**  
**0/4-20mA**

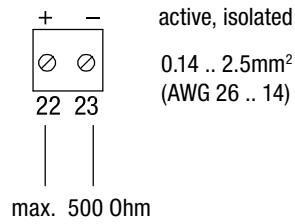

**Signal description:**  
 See page G22

**Signal output:**  
**Relay**

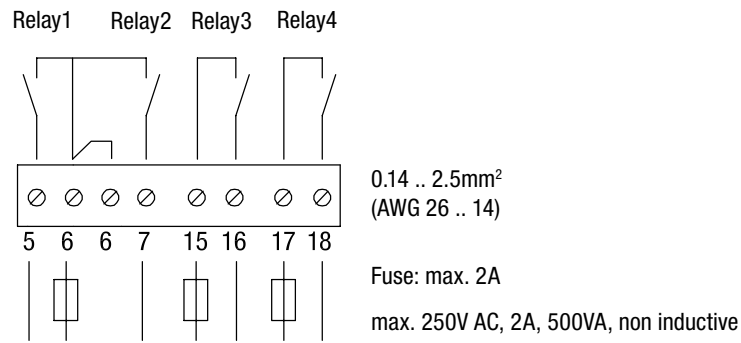

**Signal description:**  
 See page G22

**Signal output:**  
**Electronic counting pulse**

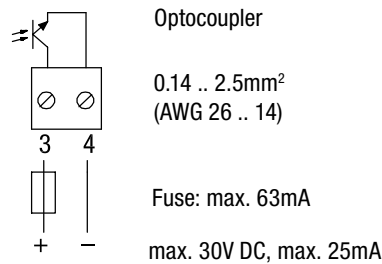

**Note:**  
 Reset pulse is done with Relay 2

**Signal description:**  
 See page G23



## Electrical installation

### Remote Box NB 9000 - Internal wiring and power supply

#### Panel mounting version

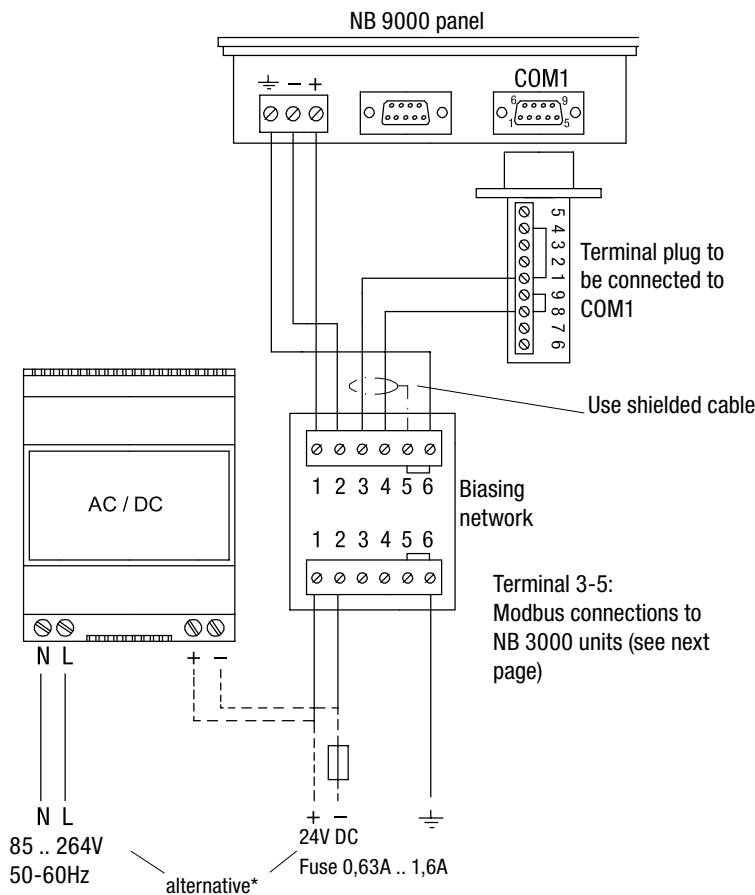

Note:  
 NB 9000 COM1:  
 Modbus D1 =  
 Pin 1 and 4.  
 Modbus D0 =  
 Pin 8 and 9.  
 Cache = shield.

Note:  
 Terminal  
 plug internal  
 connections:  
 Pin 1 and 4.  
 Pin 8 and 9.

If required: Power supply can be taken from one of the NB 3000 power supply terminals (see next page).

\* AC/DC converter:  
 Used, if AC power supply is selected

#### Wall mounting version

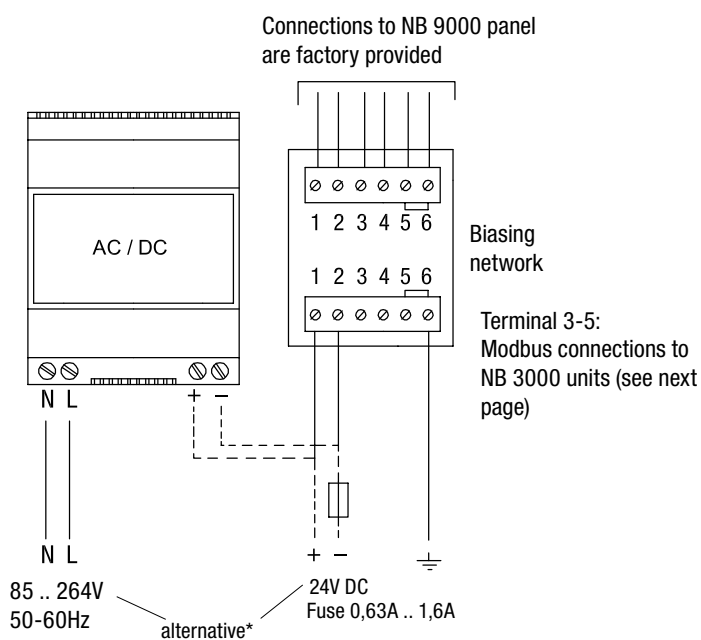

If required: Power supply can be taken from one of the NB 3000 power supply terminals (see next page).

\* AC/DC converter:  
 Used, if AC power supply is selected

## Electrical installation

### Remote Box NB 9000 - Connecting to NB 3000

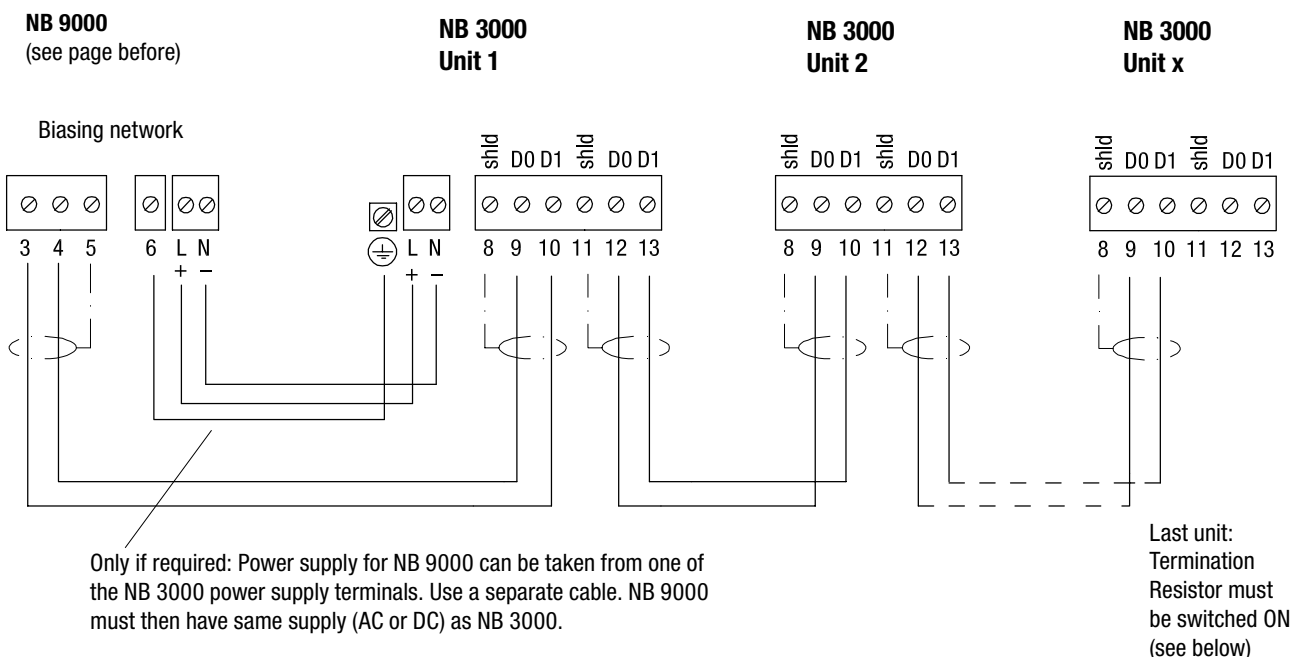

#### Recommended Modbus cables:

Cable length <50m (164 ft):

Cable length >50m (164ft) - 1000m (3270ft):

Shielded cable (specifications see page G13)

Twisted pair cable (specifications see page G13)

#### Notes:

- Installation of NB 9000 only in Non-Hazardous areas permitted
- Max. length of network: 1000m (3270ft)
- Max. 10 units NB 3000 possible
- Additional use of other signal input and output should be wired in a separate cable.
- D0, D1 = Modbus lines

#### Setting the Termination Resistor

A termination resistor must be present at both ends of the modbus network (ca. 150 Ohms between lines D0 and D1).

The biasing network of the NB 9000 implements a termination resistor at the beginning of the network.

The termination resistor of the last NB 3000 in a network must be switched on (jumper setting, see drawing).

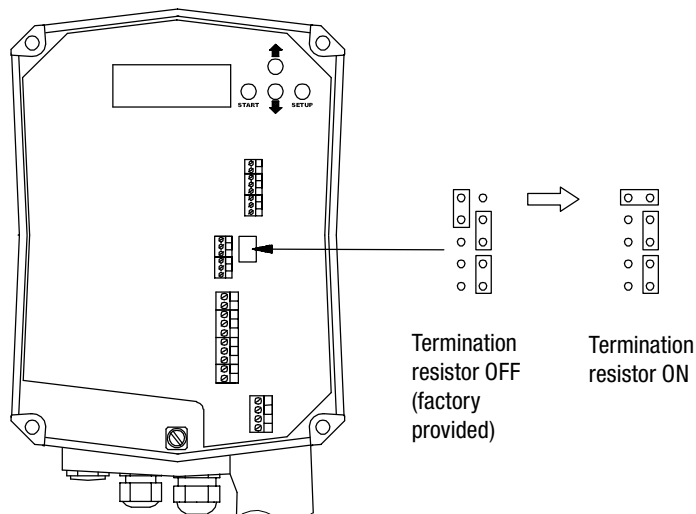

## Signal overview

### Signal input / output

**Signal input:**  
**Start of measurement**

- Floating contact (terminal 24, 25) or
- 24 V DC voltage (terminal 25, 27), current consumption approx. 25mA, observe the polarity.

Duration of starting signal: 0.7 to 5s  
 The contact must be closed or the 24V signal must be present to start.

**Measurement interruption**

Used to avoid a measurement in case of filling and to interrupt a running measurement when filling starts. When the terminal 24 und 26 are opened, the sensor weight returns to the upper stop position. If required, remove factory provided wire between terminal 24 and 26 and connect to the filling coupling. The contact must be closed to enable a measurement.

**Signal input:**  
**Full detector**

Enables to implement a full detector signal in the Modbus or Profibus. When the signal is present (terminal 24-28 closed) the yellow LED next to the display is on.

**Signal output:**  
**0/4-20mA**

Programmable to indicate a level or a volume signal. The output is updated, when the sensor weight touches the surface of the bulk good. It stays until the next measurement is done.

**Signal output:**  
**Relay**

Relais can be setted as shown in the following table:

	Relay 1	Relay 2	Relay 3	Relay 4
Factory settings	Counting pulse	Reset pulse	Failure	Upper stop position
Programmable	Limit switch 1	Limit switch 2	Maintenance	Maintenance

**Relais 1/2 set to Counting/Reset pulse:**

The counting pulse output is used to connect an external digital counter or a PLC with counting input.

**Reset pulse** (terminal 6 and 7):

After start of measurement, a reset pulse is given. It is used to reset the connected evaluation device (counter/ PLC, ...).

**Counting pulse** (terminal 5 and 6):

The counting pulse communicates the measured value to the connected evaluation device. During the downward movement of the sensor weight, this pulse is generated according to the following table:

Timing

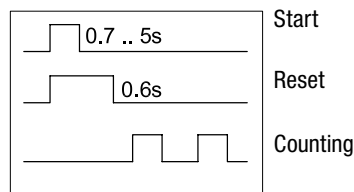

Counting pulse programmed to:	ON	OFF
10cm (1/6ft) / pulse	0.13s	0.13..0.3s
5cm (1/3 ft) / pulse	0.07s	0.07..0.15s

**Relais 1/2 set to Limit switch:**

It is possible to indicate two independent level limit switches. The limit switch signal is derivated from the analogue measurement signal (details see Programming page 27)

**Relay 3 - set to "Failure"**

The relay indicates a failure (see also programming on page 28 and diagnostics "Failure" on page 39)

**Relay 3 - set to "Maintenance"**

The relay indicates a necessary maintenance (see also programming on page 28 and diagnostics "Maintenance" on page 37)

## Signal overview

### Relay 4 - set to "Upper stop position"

The signal allows the user to determine whether the measurement has come to its end. In this case the sensor weight is in its upper stop position, relay contacts are closed.

### Relay 4 - set to "Maintenance"

The relay indicates a necessary maintenance (see also programming on page 28 and diagnostics "Maintenance" on page 37)

### Signal output: Electronic counting pulse

**Counting pulse** (terminal 3 and 4):  
 The electronic counting pulse enables a high amount of pulses to receive a high resolution of the measurement signal.

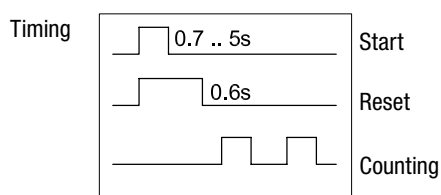

Counting pulse programmed to:	ON	OFF
	2,5cm (1/10ft) / pulse	25ms
1cm (1/20ft) / pulse	10ms	10..30ms

**Note:**

The reset pulse is done with relay 2.

### LED status

LED	Status
	Green is on
	Red is on
	Red is blinking
	Yellow in on
LEDs next to relais terminals	Yellow is on

## Diagnostics signals

### Failure

Result is a non valid measurement.  
 Red LED is on. Relay 3 indicates Failure.  
 The signal indicates critical situations. Evaluation can help to avoid losing the sensor weight inside the silo.

If Failure is indicated, the unit must be checked on site.

Failure codes description see page G39.

### Maintenance

Result is an indication for the user with still valid measurement.  
 Red LED is blinking. Relay 4 indicates Maintenance (programmable).  
 The signal enables a preventive maintenance. Evaluating can help to avoid loosing the sensor weight inside the silo.

If Maintenance is indicated, the measurement process can be continued.

Maintenance codes description see page G37.

## Programming NB 3000 Nivobob

### Quickset menu

The Quickset menu is used for fast and easy start-up of the system.

If the unit is working in normal operation (measurement mode), the SETUP button brings up the Quickset menu.

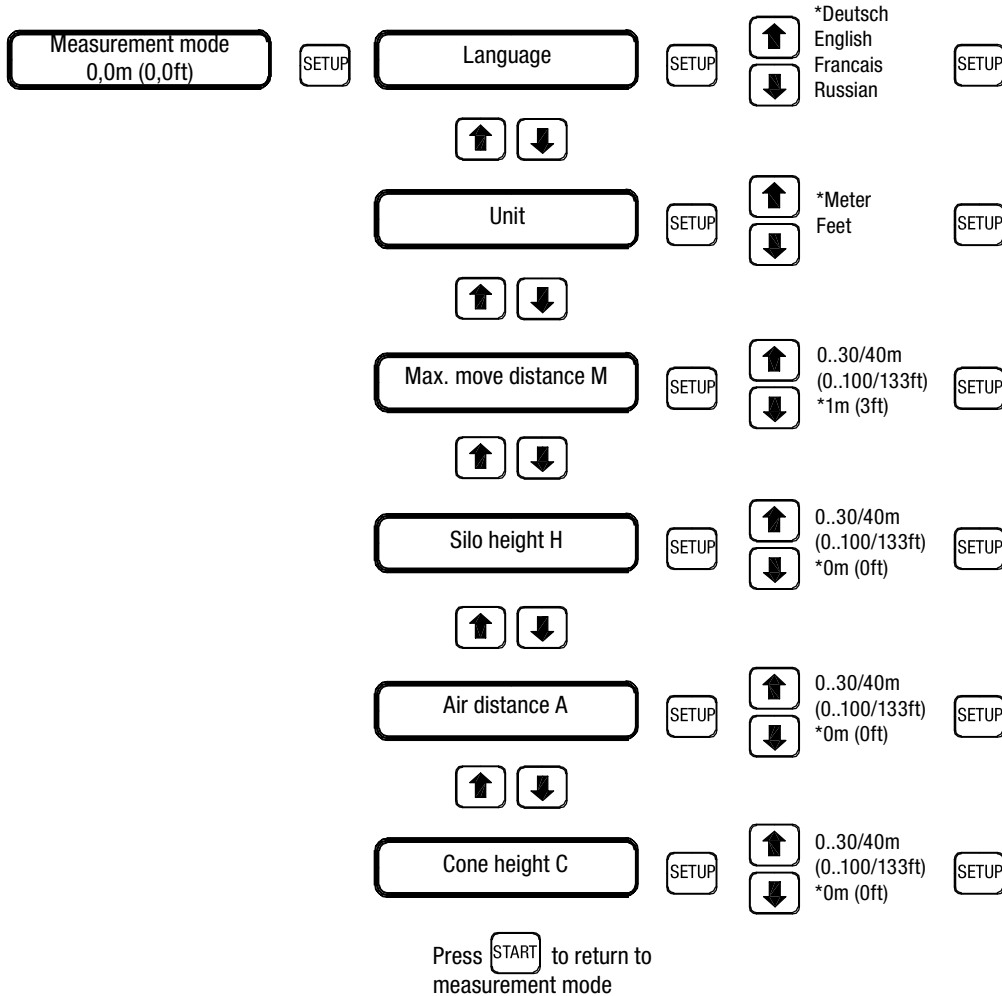

Max. adjustable length of 30/40m depending on ordered version.

\* Factory-provided

**Max. move distance M** Ensures that the weight does not enter into the silo outlet.

**Silo height H** Definition of 0% level output.  
 Note: If the maximum move distance M is smaller than the silo height H, the measured value will always be more than 0%.

**Air distance A** Definition of 100% level output.



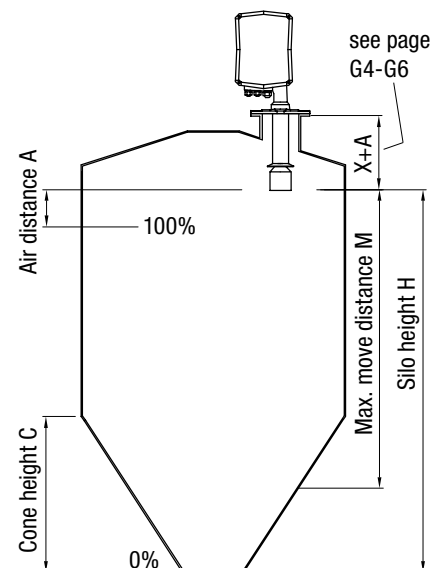

**Cone height C** Enables to set the current output as volume.  
 C = 0 Current output indicates material level  
 C > 0 Current output indicates material volume

**Note:**  
 When using the digital pulse output (terminal 5/6/7, see page G18/22) the parameters silo height H, air distance A and cone height C have no influence on the measurement value.





## Programming NB 3000 Nivobob

### Programming buttons

-  Continues with next adjustment item
-  Continues with measurement display after parameter adjustment  
Starts measurement  
Cancels a Failure or Maintenance message
-  Increases the value to be adjusted
-  Decreases the value to be adjusted

### Runtime messages

During measurement mode, following runtime indications are given:

-  Upper Stop Position is reached
-  Motor is moving the sensor weight downwards resp. upwards (fast mode)
-  Motor is moving in slow mode (shortly after motor start and before Upper Stop Position is reached)
- Blocked 24-26 open** Measurement interruption is active (terminal 24-26 not connected, see page G22)
- Blocked Modbus** Measurement interruption is active (signal is set via Modbus or Remotebox NB 9000, see also page G35)

**Note:**  
Pressing the ARROW DOWN button in measurement mode brings up more service information (not described in this manual)

### Advanced menus

(use only if necessary)

**With the advanced menus it is possible to set the outputs and to display the actual state of the unit.**

Entering the advanced menus:

If the unit is working in normal operation (measurement mode), press both "arrow" buttons together for approx. 2 seconds.

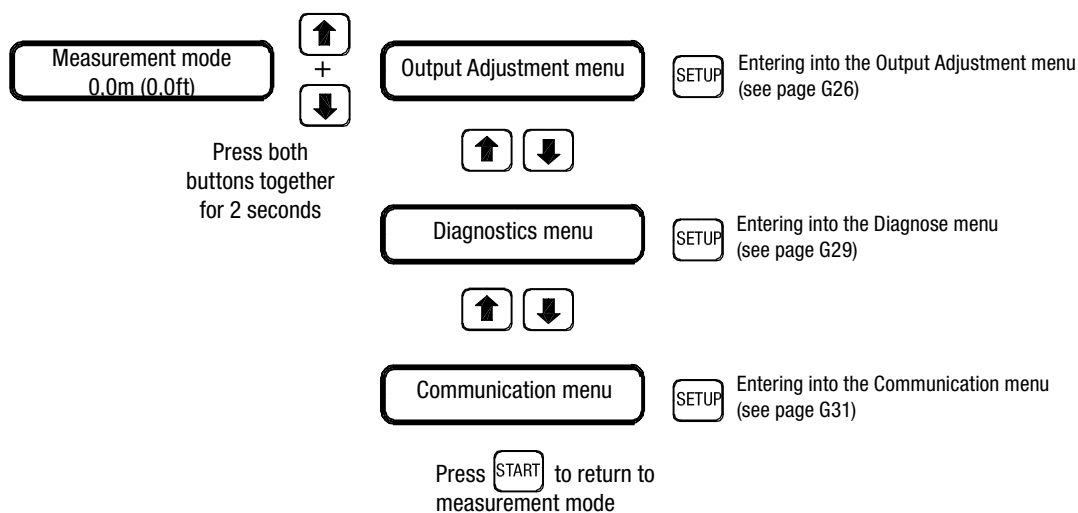

### Factory settings

To reset all programmed parameters to factory setting (default values), press the buttons ARROW UP, ARROW DOWN and SETUP together for approx. 10 seconds.

## Programming NB 3000 Nivobob

### Output Adjustment menu

The Output Adjustment menu is used for setting the 0/4-20mA, relays and internal timer

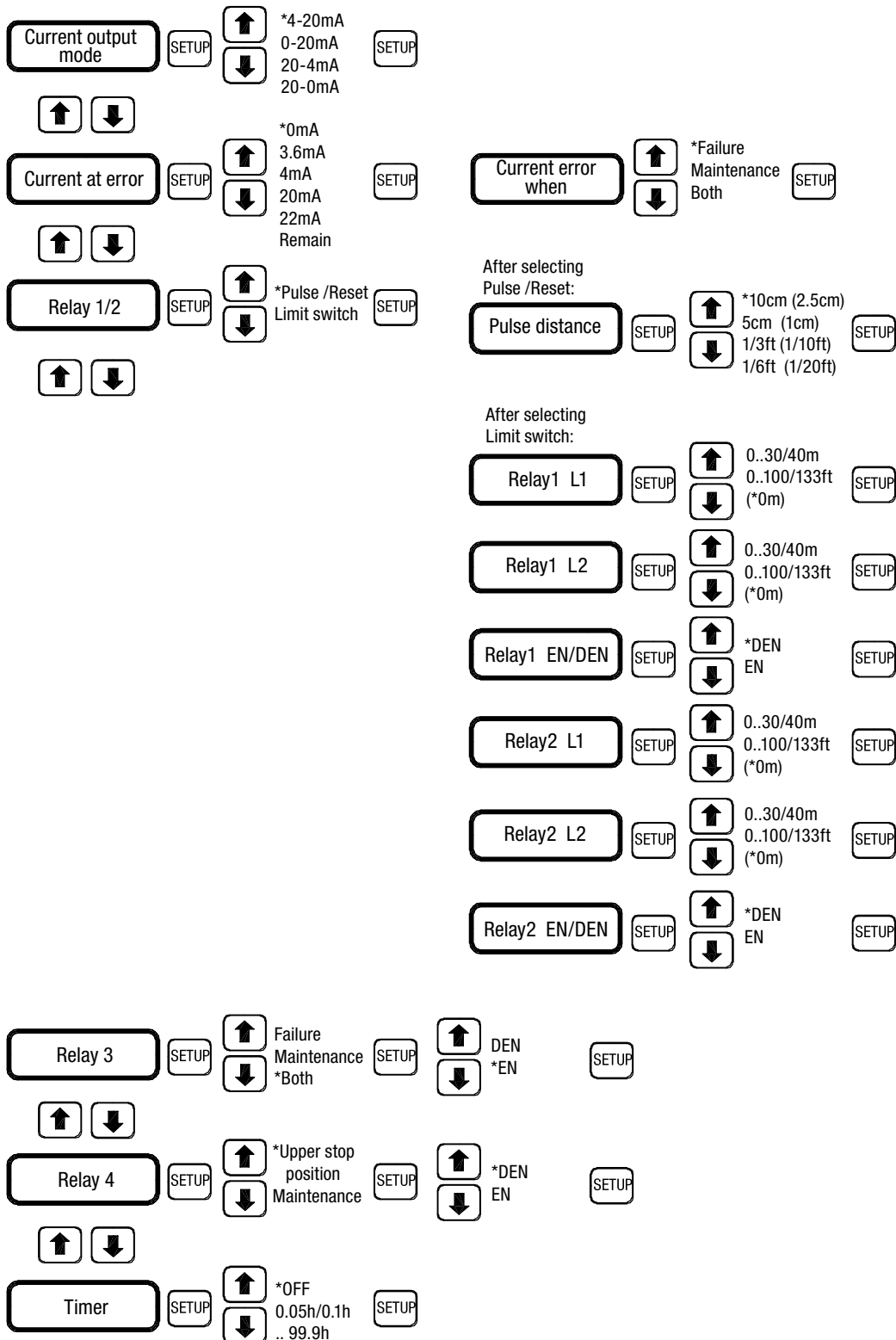

Press **START** to return to measurement mode

\* Factory provided

## Programming NB 3000 Nivobob

### Current output mode

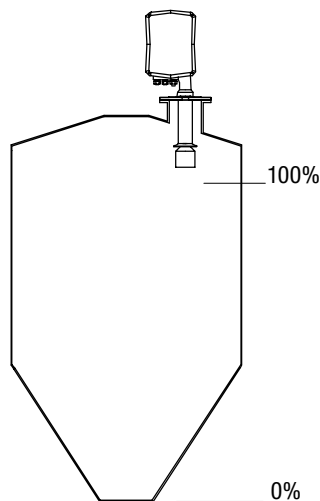

Setting	Current output at level	
	0%	100%
4-20 mA	4 mA	20 mA
0-20 mA	0 mA	20 mA
20-4 mA	20 mA	4 mA
20-0 mA	20 mA	0 mA

### Current at error

In case of error (Failure, Maintenance) the current output shows the adjusted value. It can also be adjusted, whether the current output shall indicate Failure or Maintenance or both situations.

### Relay 1/2

Selects, if Relay 1 and 2 shall work as Counting / Reset pulse output or as two independently programmable limit switches.

#### Selecting Pulse / Reset:

Relay 1 works as Counting pulse output with selected pulse rate (the values in brackets are valid for the version with Electronic counting pulse). Relay 2 works as Reset pulse. Details see Signal Overview on page G22.

#### Selecting Limit switch:

The relays are programmed with the distance from the sensor weight bottom to the required material surface switching point. The relays can be set to energise or de-energise. The relay logic is as follows:

- DEN** The relay is normally de-energised and is energised when the product rises above the L1 level. It remains energised until the product falls below the L2 level.
- EN** The relay is normally energised and is deenergised when the product rises above the L1 level. It remains deenergised until the product falls below the L2 level.
- L1** L1 is the upper switching point.
- L2** L2 is the lower switching point.  
Note: L2 must always be greater than L1.

Note: The limit switch outputs are updated after a measurement cycle.

LED at relay	Relay
○	OFF De-energised
☀	ON Energised

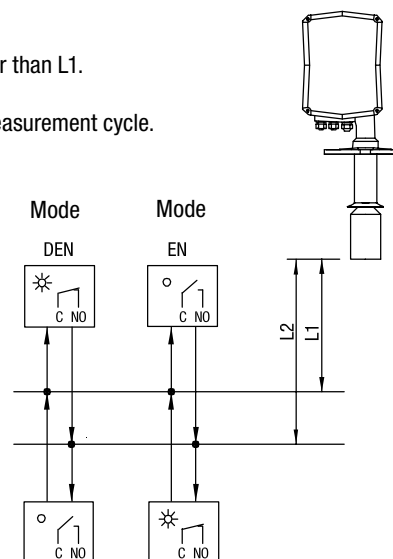





## Programming NB 3000 Nivobob

---





### Relay 3

Selects, if relay 3 shall indicate Failure, Maintenance or both situations.

Failure / Maintenance	Mode DEN	Mode EN
Present		
Not present		

### Relay 4

Selects, if relay 4 shall indicate "Upper stop position" or Maintenance.

Upper stop position / Maintenance	Mode DEN	Mode EN
Present		
Not present		

### Timer

Automatic start of measurement with timer function.

The timing interval between two measurements can be adjusted between 0.05h (3 minutes) for the version with brushless motor (otherwise 0,1h (6 minutes)) and 99.9 hours. Position „off“ causes no automatic measurement start.

The timer will be reset:

- after finishing a measurement
- after linking the terminals 24/26 (measurement interruption during filling)

For automatic measurement at a predetermined time of day, an external start unit connected to terminals 24/25/27 is necessary.

To avoid needless wear and tear, the unit should not be started more often than necessary.

## Programming NB 3000 Nivobob

### Diagnostics menu

The Diagnostics menu is used to diagnose the unit status and for manual motor driving mode

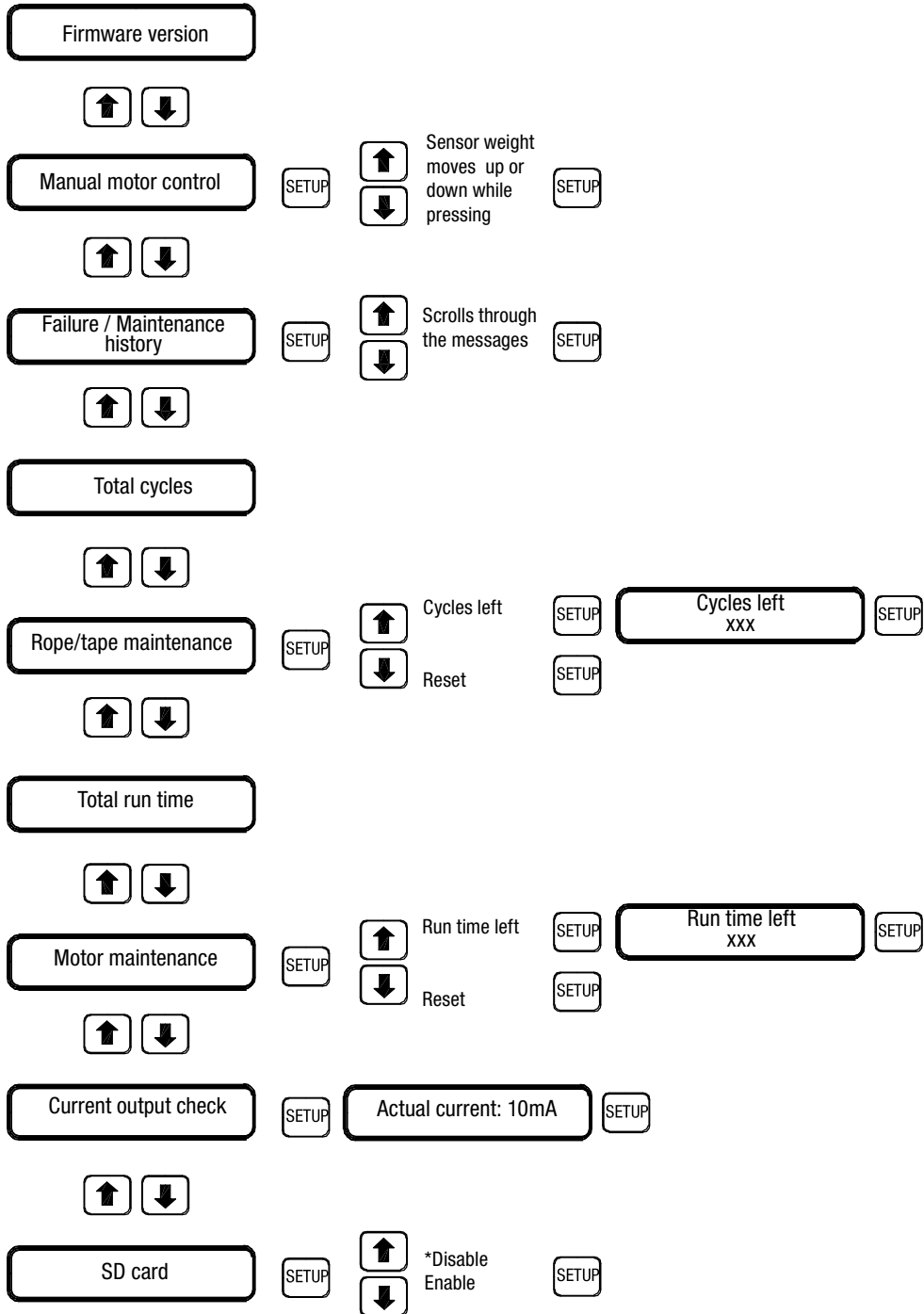

Press **START** to return to measurement mode

## Programming NB 3000 Nivobob

---

<b>Firmware version</b>	States the firmware version of the unit.
<b>Manual motor control</b>	<p>The motor moves the sensor weight upwards while the "ARROW UP" button is being pushed.                  The motor moves the sensor weight downwards while the "ARROW DOWN" button is being pushed.</p> <p>Note: If the sensor weight is in the upper stop position or touching the bulk material surface or after the max. move distance, the motor is automatically stopped.</p> <p><b>CAUTION:</b> Avoid the sensor weight reaching the outlet position of the silo.</p>
<b>Failure / Maintenance history</b>	<p>Indicates the last 93 error messages related to the motor run time after switching on the power supply for the first time. Messages can be scrolled up and down with the "ARROW" buttons. If "None" is indicated, there is no message filed. The messages and the time information are permanently filed even when the power supply is switched off. Details of the messages see page G37 - 39.</p> <p>Examples of indicating a Failure:</p> <p><b>Hist. 0512h 1350s                  0348h 2400s +F11</b>                  Meaning: Actual motor run time is 512 hours and 1350 seconds after first power on. At 348 hours and 2400 seconds the Failure F11 came up</p> <p><b>Hist. 0512h 1350s                  0356h 1920s -F11</b>                  Meaning: Actual motor run time is 512 hours and 1350 seconds after first power on. At 356 hours and 1920 seconds the Failure F11 was resetted</p>
<b>Total cycles</b>	Indicates how many measurement cycles have been performed up to now.
<b>Rope/tape maintenance</b>	<p><b>Cycles left:</b> Indicates how many measurement cycles are left until the next rope/tape failure message F16 will appear and the unit will stop working.</p> <p><b>Reset:</b> Can be done after a rope/tape change, if the Maintenance message was not yet present. It sets the internal counter to zero to have the full amount of measurement cycles until the next maintenance message will appear.</p> <p>Note 1: After a Maintenance message is reset with the "START" button, the rope/tape maintenance counter is automatically set to zero.                  Note 2: The number of preset cycles to the next maintenance message depends on the use of rope or tape version.</p>
<b>Total run time</b>	Indicates, how long the motor has been running up to now (in hours).
<b>Motor maintenance</b>	<p><b>Run time left:</b> Indicates, how much motor run time (in hours) is left, until the motor failure message F17 will appear and the unit will stop working.</p> <p><b>Reset:</b> Can be done after a motor change, if the Maintenance message was not yet present. It sets the internal counter to zero to have the full amount of motor run time until the next maintenance message will appear.</p> <p>Note 1: After a Maintenance message is reset with the "START" button, the motor maintenance counter is automatically set to zero.</p>
<b>Current output check</b>	Enables to check, if the current output is working proper. The current output is forced to 10mA. This can be evaluated by an external connected multimeter.
<b>SD card</b>	<p>Optional use for service aspects (not explained in this manual).                  After connecting a SD card to the electronics, this parameter shall be set to "Enable". Before removing the SD card, it shall be set back to "Disable".</p>

## Programming NB 3000 Nivobob

### Communication menu

The Communication menu is used for setting parameters of Modbus RTU and Profibus DP

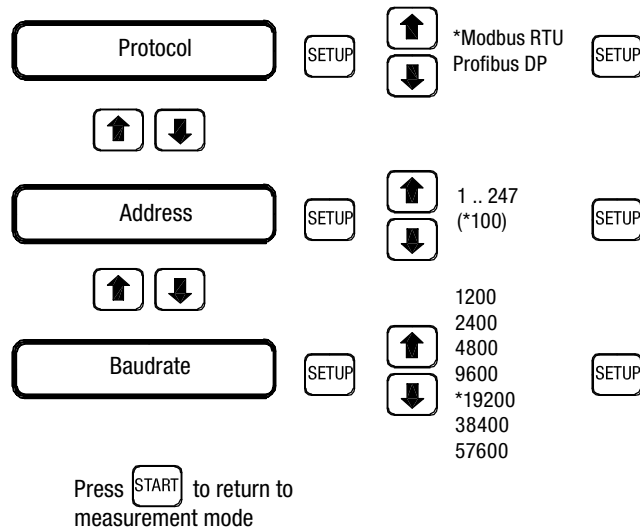

\* Factory provided

**Protocol** Selects if Modbus RTU or Profibus DP protocol is used.

**Adress** Selects the used communication adress.

**Baudrate** Selects the used baudrate.

## Programming NB 3000 Nivobob

### Modbus Register

The following registers describe the communication via Modbus.

#### CAUTION

Writing to the registers different from what is stated will cause a miss function of the unit

Register address	Register name	Register description	Register use	Default value
------------------	---------------	----------------------	--------------	---------------

#### Setup

40001	M_LANGUAGE	Language on the menu DEUTSCH 0 ENGLISH 1 FRANCAIS 2 RUSSIAN 3	R/W	0
40002	M_UNIT	Unit used for distance visualisation METER 0 FEET 1	R/W	0
40003	M_MAX_MOVE_DIST	Max. move distance mm	R/W	1000
40004	M_SILO_HEIGHT	Silo height mm	R/W	0
40005	M_AIR_DIST	Air distance mm	R/W	0
40006	M_CONE_HEIGHT	Cone height mm	R/W	0
40022	M_TIMER	Timer interval (for automatic start of measurements), in 1/100 hours (Off = 0) Notes: 1/100 hour = 36 sec Minimum time for standard motor: 0,10 hours (value =10) Minimum time for brushless motor: 0,05 hours (value = 5)	R/W	0

#### Measurement

40051	M_START	Start of a measurement Start 1 Note: The Modbus master must set the register back to 0 after the measurement has started. The started measurement is indicated as "Busy" in the M_STATUS register	W	
40046	M_DISTANCE	Actual measured distance, in mm Note: After the unit has finished the measurement, the M_STATUS register states "Ready, measurement valid" (the Modbus master must read the M_STATUS register). Then the data on the register M_DISTANCE is valid.	R	
40055	M_VOLUME	Actual measured volume (considering the programmed cone height), in % See note on register M_DISTANCE	R	
40052	M_INHIBIT	Block command (allows to block the unit, so that no measurement can be started) No block 0 Block 1 The unit will remain blocked as long as the register has the value "Block". Note: Unit states the blocked status through the M_STATUS register.	W	0
40045	M_STATUS	States the functional status of the unit Blocked 1 Ready, measurement not valid 2 Ready, measurement valid 6 Busy 8 Failure present 16 Temporary not ready 32 -> Explanation see next page	R	

## Programming NB 3000 Nivobob

		Explanation: Blocked: No measurement can be started. Ready: A new measurement can be started. Measurement valid: Indicates a valid measurement. Measurement not valid: Indicates a maintenance condition (details see M_MAINTENANCE) Busy: A measurement is actually running. Failure present: No new measurement can be started (details see M_FAILURE) Temporary not ready: No measurement can be started due to internal actions (usually during upwards movement of the sensor weight).	R	
40057	M_FULL_DETECTOR	States the full detector input status Contact open (24-28) 0 Contact close (24-28) 1	R	

### Diagnostics

		Total measured cycles up to now = "M_TOTAL_CYCLES" + 36535 * "M_TOTAL_CYCLES_H"		
40026	M_TOTAL_CYCLES	Total measured cycles up to now, in cycles	R	
40044	M_TOTAL_CYCLES_H	Total measured cycles up to now, in 36535 cycles	R	
		Measurement cycles left until failure message F16 will appear = "M_CYCLES_LEFT" + 36535 * "M_CYCLES_LEFT_H"		
40028	M_CYCLES_LEFT	Measurement cycles left until F16 will appear, in cycles	R	
40050	M_CYCLES_LEFT_H	Measurement cycles left until F16 will appear, in 36535 cycles	R	
		Total motor run time up to now = "M_TOTAL_RUN_TIME" hours + "M_TOTAL_RUN_TIME_S" seconds		
40029	M_TOTAL_RUN_TIME	Total motor run time up to now, in hours	R	
40048	M_TOTAL_RUN_TIME_S	Total motor run time up to now, in seconds	R	
40031	M_RUN_TIME_LEFT	Motor run time left until F17 will appear, in hours	R	
40053	M_FAILURE	Failure status of the unit (stated on a bit basis) F10 – Motor or motor-driver-electronic defect                      b0 = 1 F11 – Sensor weight is buried    b1 = 1 F12 – Rope/tape broken    b2 = 1 F13 – Rope/tape too short or jammed in the rope roller                      b3 = 1 F15 – Not enough current from power supply                              b4 = 1 F16 – Service interval rope/tape    b5 = 1 F17 – Service interval motor    b6 = 1	R	
40054	M_MAINTENANCE	Maintenance status of the unit (stated on a bit basis) M10 – Deflection pulley moves not smooth                                      b0 = 1 M11 – Sensor weight blocked in upper position                                      b1 = 1 M16 – Service interval rope/tape    b3 = 1 M17 – Service interval motor    b4 = 1	R	

### Communication

40034	M_PROTOCOL	Bus protocol used for communication Modbus 0	R/W	0
40035	M_ADDRESS	Device address 1 to 247	R/W	31
40036	M_BAUDRATE	Communication speed 1200 baud 0 2400 baud 1 4800 baud 2 9600 baud 3 19200 baud 4 38400 baud 5 57600 baud 6	R/W	4

R/W: read/write      R: read only      W: write only  
 Firmware Version 1.3

## Programming NB 9000 Remote Box

### General

- Programming**
- The programming can be done either directly on the Nivobob NB 3000 unit or via the Remote Box NB 9000. If programming is done on the Nivobob NB 3000 unit, no more programming of the Remote Box NB 9000 is required.
  - All programmed data are stored in the NB 3000 unit and not in the Remote Box NB 9000.

- Addressing**
- The Remote Box NB 9000 addresses are fixed: Silo1 = Address 1, Silo 2 = Address 2 etc. The connected NB 3000 units must be set to these address (see page G31)

- Baudrate**
- The Remote Box NB 9000 always works with 19200 baud. The NB 3000 units are factory provided with 19200 baud. No setting is necessary.

## Programming NB 9000 Remote Box

- General note**
- When operating the display can have a delayed reaction, while the actual data are being loaded.

- Start after Power On**
- The actual Firmware version is displayed
  - Press on the Touchscreen to enter into the the Home page

- Home page**
- Three Silos are indicated per page  
 The actual level is displayed in m (or feet), the volume as a bargraph.
  - NEXT / PREVIOUS switches to the next or previous silos
  - After switching on the power supply, the number of connected NB 3000 must be set (setting on the last page next to Silo 10).
  - If a "!" is stated in the level display, there is no communication between Remote Box NB 9000 and NB 3000. (Check address setting on the NB 3000 units, set the number of connected NB 3000 next to Silo 10)
  - A flashing level display indicates, that a Maintenance or Failure message is present.
  - Press on a Silo to enter in the Overview page per silo

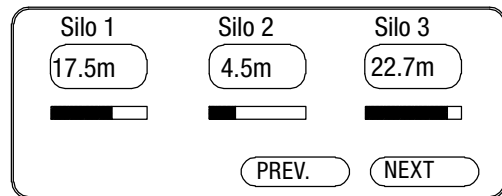

- Overview page per silo**
- There is one page per silo
  - The actual level, volume and volume bargraph is displayed.  
 A flashing display indicates, that a Maintenance or Failure message is present.
  - START will start a measurement of the respective NB 3000. After the sensor weight has reached the material surface, the display is updated.
  - BLOCKED is displayed, if the measurement interruption is active and no measurement can be started. This could be done manually (see Quickset page below) or by the measurement interruption input (see page G17 and G22) .
  - HOME switches back to Home page
  - QUICKSET switches to Quickset page
  - DIAG switches to Diagnose page

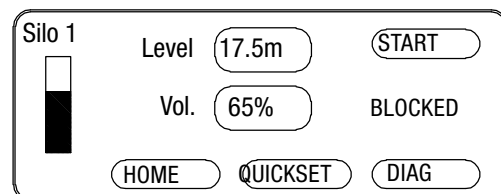

## Programming NB 9000 Remote Box

### Quickset page

- Programming of:  
 Max. move distance M  
 Silo Height H  
 Air Distance A  
 Cone height  
 See page G24 for details.

Programming via keypad after pressing the touchscreen at the spot, where the value is stated. Confirm with ENTER.

If the programmed values are out of range, the values are first stated in the display, but then will be changed to the max. possible values after a few seconds.

A flashing display indicates, that the NB 3000 is actually been programmed on the silo.

Note: The 4-20mA output is automatically programmed by setting these values.

- NEXT switches to Quickset page 2
- TIMER sets the timer for automatic starting (see page G28)
- BLOCKED or ENABLED avoids or enables the start of a measurement (measurement interruption)
- BACK switches to the Overview page per silo.

### Diagnostics page

- Displays if a Failure or Maintenance message is present. The respective box is highlighted and states the Failure or Maintenance code. See page G37-39 for details.

Note 1: In case of Failure or Maintenance, the level display on the Home page and Overview page per silo will flash.

Note 2: The messages cannot be reset from the Remote Box, but must be reset on the silo, because an action on site is required.

NEXT switches to Diagnostics page 2

- ROPE/TAPE CYCLES see page G30
- MOTOR RUN TIME see page G30
- BACK switches to the Overview page per silo.

## Commissioning: Interface measurement

### General items

**Applications** Measurement of solids in water like mud, sand, bed ash, sediment, stones etc.  
**Rope version:** The material surface can be soft / muddy or compact. Sensitivity adjustment possible.  
**Tape version:** The material surface must be compact (the sensor weight cannot sink in). No sensitivity adjustment possible.

**Principle** The sensor weight penetrates into the water and stops when touching the solid surface.

### Sensitivity adjustment (rope version)

**General** The sensitivity (needed release force for the sensor weight when touching the solid surface) can be set to the requirements of the application.  
 Sensitivity adjustment is done by lowering the sensor weight into the water by using the "Manual motor control" (see page G29).

**1. Coarse adjustment** Coarse adjustment is done to avoid the detection of the water surface.

When penetrating into the water, the weight must not float. This can be checked by watching the deflection-pulley-bar. If the deflection-pulley-bar will move briefly upwards while penetrating into the water, the sensor weight floats and needs to be heavier. This is achieved by unscrewing the lid of the sensor weight and replacing one or more plastic discs by stainless steel discs. For soft/muddy surfaces the sensor weight shall be as light as possible to keep it from sinking into the bulk material surface (see step 2).

Note: It is important that the sensor weight is completely filled with discs to avoid intrusion of air.

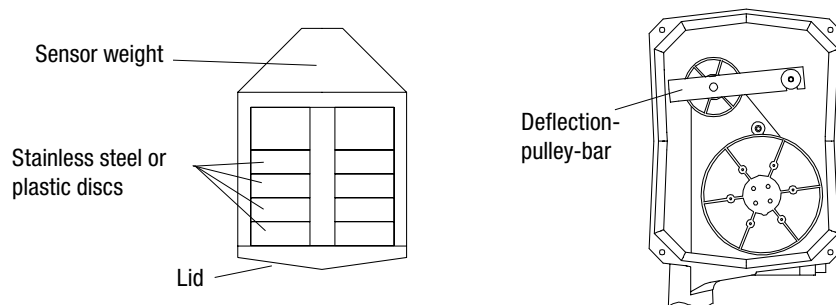

**2. Fine adjustment** Fine adjustment is done to keep the sensor weight from sinking into a soft/muddy material surface.

- Turn adjustment nut anti clockwise: measurement becomes more sensitive (for soft/muddy surface)
- Turn adjustment nut clockwise: measurement becomes less sensitive (for more compact surface)
- Fix the adjustment nut with the counter nut

The adjustment was successful if the sensor weight penetrates the water surface easily and detects the material surface without sinking in.

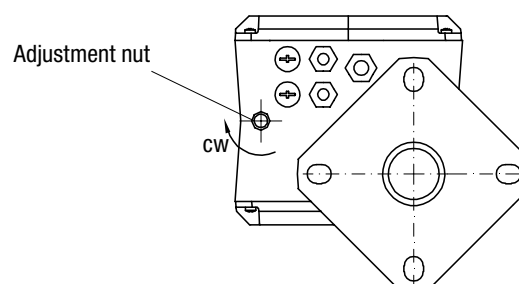

## Diagnostics: Maintenance

Result is an indication for the user with still valid measurement.  
 Red LED is blinking. Relay 4 indicates Maintenance (programmable).  
 The signal enables a preventive maintenance. Evaluating the signal can help to avoid losing the sensor weight inside the silo.  
 If Maintenance was indicated, the measurement process can be continued.

Maintenance code	Description	Performance of the device	Solution
M10	Deflection pulley moves not smooth / regular	Message is shown, measurement can be continued. If the following 5 measurement cycles after indication are o.k., the message will automatically disappear.	Check for proper movement of the pulley. Check for possible slipping of the rope/tape on the pulley.
M11	Sensor weight blocked in "upper stop position" or block distance of sensor weight to short	The unit tries to start 5 times. If the sensor weight is not released during this time, the message is shown. If after a new measurement start the sensor weight is released, the message will automatically disappear.	Release sensor weight. Ensure, that the min. moving distance (block distance) is > 200mm (7.87")
M12	SD card not working properly	In the diagnose menu the setting "SD card Enable" is done but SD card is not present or not working properly	Set the menu to "SD card Disable" or change SD card
M16	Service interval: rope / tape	The amount of measurement cycles has reached 70% of the rope/tape lifetime.  To further guarantee faultless performance, it is strongly recommended to change the rope/tape.  After resetting the message, the internal counter for the rope/tape cycles is reset to zero.  If the message is not reset, the unit will continue measuring, until 90% of the rope/tape lifetime is reached. Then Failure F16 will come up.	Change rope /tape.
M17	Service interval: motor	The actual run time has reached 70% of the motor lifetime.  To further guarantee faultless performance, it is strongly recommended to change the motor.  After resetting the message, the internal counter for the motor run time is reset to zero.  If the message is not reset, the unit will continue measuring, until 90% of the motor lifetime is reached. Then Failure F17 will come up.	Change motor

By pushing the START button the actual stated messages shown on the display can be reset.

If more than one message is present, the one with a lower code is shown on the display. After reset with the START button, the next one will be stated.

Possibilities to see a maintenance history: see page G29.

### CAUTION

**Before removing the rope/tape roller, remount the unit from the silo to avoid, that the sensor weight can fall into the silo.**

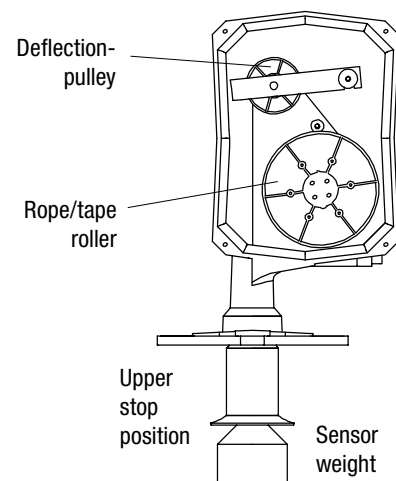

## Diagnostics: Maintenance

### Rope/Tape lifetime

The expected life time (measurement cycles) for the rope/tape is:

Rope version: approx. 100000  
 Tape version: approx. 250000

Note: These values refer to lifetime tests under the following conditions:  
 No excessive material influence. The sensor weight meets an inclined surface, so that an oscillating movement of the sensor weight during upwards movement is caused.

The maintenance message is displayed at 70%, the failure message at 90% of the expected lifetime to provide some safety. For further information see message M16 and F16.

See figure on right hand for the operating time depending on the measurement cycles per day.

For applications with adverse conditions it is recommended to change the rope/tape more frequently.

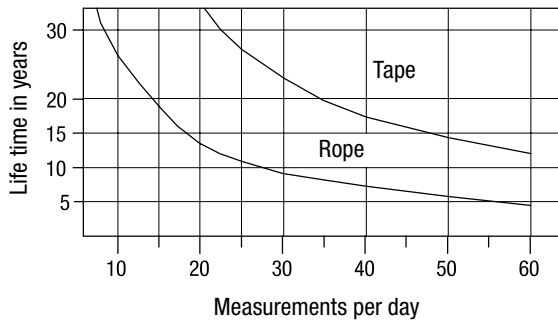

### Motor lifetime

The expected life time (run time) for the motor is:

Version for high measurement frequency (brushless motor):  
 approx. 60000 hours

Version with standard motor (brush motor):  
 approx. 3500 hours

The maintenance message is displayed at 70%, the failure message at 90% of the expected lifetime to consider some safety. For further informations see message M17 and F17.

See figure on right hand for the operating time depending on the measurement cycles per day.

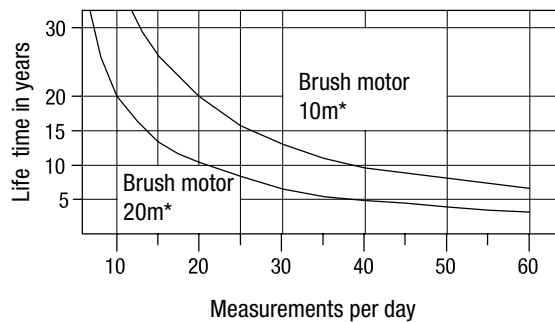

\*average measurement distance

## Diagnostics: Failure

Result is an invalid measurement.

Red LED is on. Relay 3 indicates Failure.

The signal indicates critical situations. Evaluating the signal can help to avoid losing the sensor weight inside the silo.

If Failure is indicated, the unit must be checked on site.

Failure code	Description	Indication	Performance of the device	Solution
F10	Motor or motor-driver-electronic defect	Motor does not rotate when it is actuated. Evaluation by the hallsensor on the rope/tape roller.	If possible, the sensor weight will be moved up to the "Upper stop position".	Check motor connection. Motor or electronic change.
F11	Sensor weight is buried or jammed	Difference of distance between down and up movement too big. Evaluation by the hallsensor on the rope/tape roller.	Motor moves 4 seconds upwards, then waits 10 seconds. After that motor moves shortly downwards and then upwards again. If the sensor weight is still jammed, this cycle is repeated 5 times. After that the cycle goes on with a delaytime of one hour.	Release the sensor weight. Make sure, that the sensor weight can move freely.
F12	Rope / tape broken	Motor is running but the upper stop position is not reached. Evaluation by the hallsensor on the rope/tape roller on the deflection pulley bar.	Motor moves upwards. If after a certain time the upper stop position is not reached, the motor stops.	Repair of rope/tape break. Check, if rope/tape maintenance was properly done. Check possibility of buried sensor weight.
F13	Rope / tape too short or rope jammed in the rope roller	The deflection pulley and the rope/tape roller move in different directions. Evaluation by the Hall sensors on the pulley and the rope/tape roller.	Motor direction is selected so the sensor weight moves upwards until upper stop position is reached.	Check if the rope/tape is too short compared to the adjusted minimum safety setting. Check if the rope is jammed in the rope roller and wound in the wrong direction.
F15	Not enough current available from DC power supply (DC version only)	Supply voltage drops during function.	Sensor weight is moved to the upper stop position.	Enable enough supply current according to the technical data specification.
F16	Service interval: rope/tape	The amount of measurement cycles is 90% of the rope/tape lifetime. See also maintenance message M16.	The measurement cannot be restarted.	Change rope or tape.
F17	Service interval: motor	The actual run time is 90% of the motor lifetime. See also maintenance message M17.	The measurement cannot be restarted.	Change motor.

**By pushing the START and SETUP button together for 2 seconds, the message shown on the display can be reset.**

Possibilities to see a failure history: see page G29.

### CAUTION

**Resetting F16 or F17 without changing the rope/tape respective the motor will cause material damage by a broken rope/tape.**

**Before removing the rope/tape roller, remount the unit from the silo to avoid, that the sensor weight can fall into the silo.**

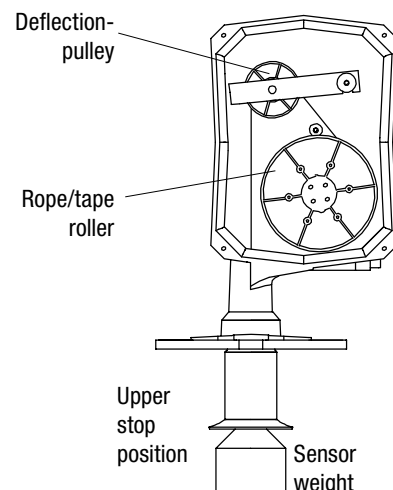

## Notes for use in Hazardous Locations

### ATEX Zone classification

Category	useable in zone	
1 D	20, 21, 22	* in case of conductive dust, additional requirements for installation are necessary.
2 D	21, 22	
3 D*	22	

### ! Permitted zones (categories) for mounting in partition wall

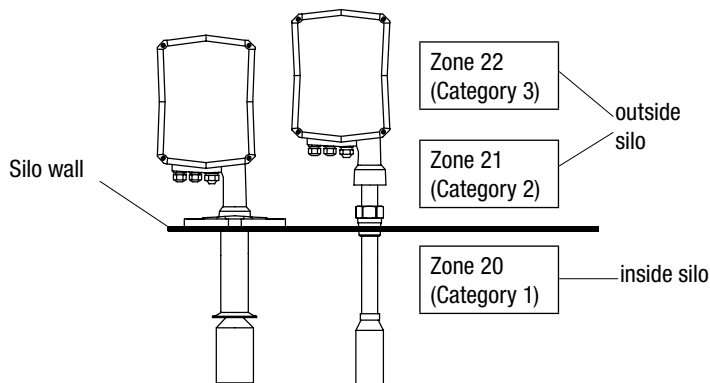

### ! General notes

#### Marking

Devices with Ex-approval are marked on the type plate.

#### Process pressure for ATEX

The device construction allows process over-pressure up to 0.3bar (4.4psi) (option 1.7bar (25psi)). These pressures are allowed for test purposes. The definition of the ATEX is only valid for a silo-over-pressure between -0.2..+0.1 bar (-2.9..+1.45psi). Outside of these pressures the approval is not valid.

#### Process and ambient temperature

The permitted temperature ranges are marked on the type plate.

## Notes for use in Hazardous Locations

### ! Maximum Surface Temperature

The temperature marking on the name plate  refers to the instruction manual. On the following table the relevant temperature ratings are shown.

The maximum surface temperature and the temperature class refer to the warmest area outside on the unit which can occur in failure case (according to EX definition).

**Version for process temperature max. 80°C (176°F) / max. 150°C (302°F)**

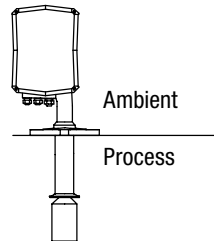

**Version for process temperature max. 250°C (482°F)**

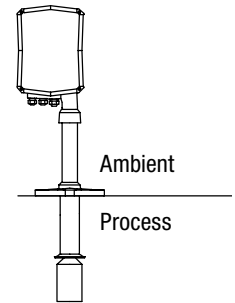

Max. ambient temperature	Max. process temperature	Max. surface temperature	Temp. class
60°C (140°F)	80°C (176°F)	130°C (266°F)	T4
40°C (104°F)	90°C (194°F)	130°C (266°F)	T4
	100°C (212°F)	130°C (266°F)	T4
	110°C (230°F)	130°C (266°F)	T4
	120°C (248°F)	130°C (266°F)	T4
	130°C (266°F)	130°C (266°F)	T4
	135°C (275°F)	135°C (275°F)	T4
	140°C (284°F)	140°C (284°F)	T3C
	150°C (302°F)	150°C (302°F)	T3C

Max. ambient temperature	Max. process temperature	Max. surface temperature	Temp. class
60°C (140°F)	80°C (176°F)	130°C (266°F)	T4
	130°C (266°F)	130°C (266°F)	T4
	135°C (275°F)	135°C (275°F)	T4
	140°C (284°F)	140°C (284°F)	T3C
	150°C (302°F)	150°C (302°F)	T3C
	160°C (320°F)	160°C (320°F)	T3C
	165°C (329°F)	165°C (329°F)	T3B
	170°C (338°F)	170°C (338°F)	T3A
	180°C (356°F)	180°C (356°F)	T3A
	190°C (374°F)	190°C (374°F)	T3
	200°C (392°F)	200°C (392°F)	T3
	210°C (410°F)	210°C (410°F)	T2D
	215°C (419°F)	215°C (419°F)	T2D
	220°C (428°F)	220°C (428°F)	T2C
	230°C (446°F)	230°C (446°F)	T2C
	240°C (464°F)	240°C (464°F)	T2B
	250°C (482°F)	250°C (482°F)	T2B

### ! Static discharge of the material surface

It must be ensured that no static discharge can occur when the grounded metal sensor weight or rope /tape touches the surface of the bulk material. If this can not be ensured, the safe use of the unit is NOT guaranteed. The responsibility for this rests with the user. In case of in clarity an assessment from a notified body is necessary.

From the manufacturer side a version with a plastic sensor weight and additional plastic rope insulation part is available on request. This keeps a 500mm (19.7") distance from the material surface to the grounded rope/tape.