

## Table of contents

---

	Page
NT 10 Digital meter, current loop display 4-20 mA	G2
-----	
NT 20 Digital meter, signal input 0-20 mA, 4-20 mA, 0-10 V 2 point levels programmable	G7
-----	
NT 30 Digital meter, impulse counter 2 point levels programmable	G11
-----	
NT 40 Analogue meter, signal input 4-20 mA	G16

Technical information subject to change

We assume no liability for printing errors

Different variations to those specified are possible

Please contact our technical staff

## NT 10

The NT 10 is powered by the 4-20mA current loop. The 4-digit display shows the level on a 7 segment display.

### Operation

The NT 10 is configured using 3 buttons.



- Programme button P:                      The programme button P accesses the programme mode and executes the various functions in programme mode.
- Arrow DOWN button (minus button):    The arrow DOWN button is used for adjustment of the parameters.
- Arrow UP button (plus button):         The arrow UP button is used for adjustment of the parameters.

### Mounting

The user and display elements are on the front. The NT 10 is fixed in place with a plastic seal. The terminal block for electrical wiring is on the back.

The NT 10 is intended for mounting on the control panel. Before fitting, the panel cut-out must be prepared according to the dimensions and tolerances shown in the technical data.

Before inserting the instrument, the plastic seal must be removed carefully using a suitable screwdriver. Insert the instrument into the panel and then replace the plastic seal. Hold the NT 10 in place and press the seal gently with the screwdriver so that it is flush against the panel. To remove the NT 10 follow the above steps in the reverse order.

### Electrical connection

Electrical connection is on the rear of the NT 10. The NT 10 is powered via the current loop and therefore does not require its own power supply.

#### Wiring plan

clamp	Clamp label
1	I <sub>B</sub>
2	I <sub>OUT</sub>
3	I <sub>IN</sub>
4	I <sub>B</sub>

## NT 10

### Wiring example

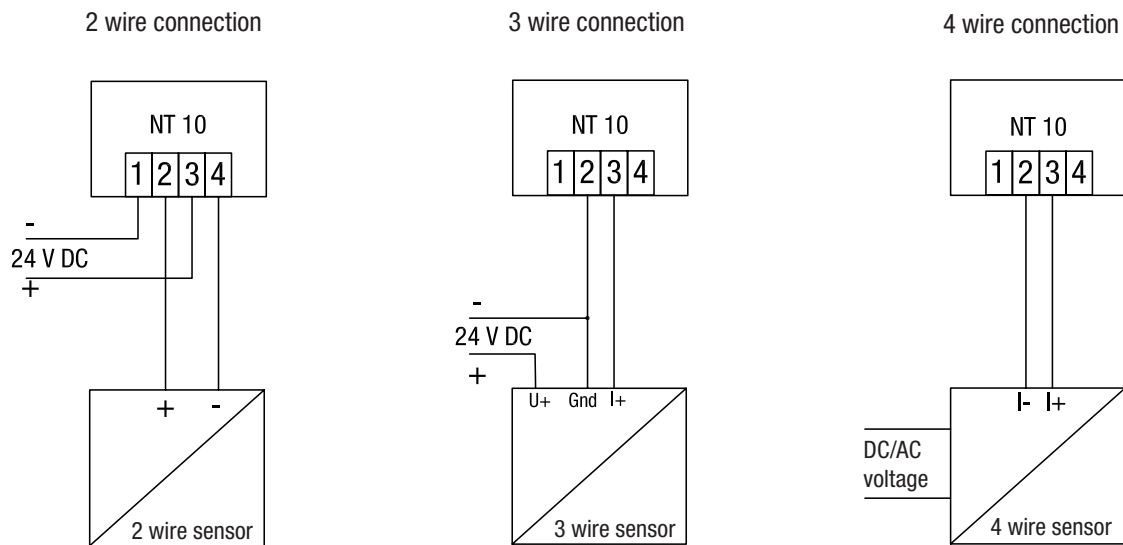

### Programming steps

To change into programming mode

Press the P button for the first programme number PN 0

To change between the programme numbers

Press the P button and the arrow UP button to show the range of PN 0 to PN200.

To show the programmed value in the programme number

Once the required programme number is shown in the display, press the arrow UP button to shown the programmed value.

To change the programmed value

Follow the steps above to display the value. The first digit on the right will flash  
 Use the UP and DOWN buttons to change to the required value. Press P and then the second digit from the right will flash.  
 Repeat as before until all digits have been set. Then press P for 1 second to save the new value. For a brief moment the NT 10 will show dashes in the display.

After approximately 7 seconds the NT 10 will return to operating mode.

## NT 10

### Table of the programme numbers

PN	Function	Value range	Factory setting
Input			
0	Type of measurement signal	0 = programming of the display of the min value and the max value of the input signal 1 = 4 - 20mA	0
1	Display by 20mA or max value of the input signal	-999...9999	1000
2	Display by 4mA or min value of the input signal	-999...9999	0
3	Decimal place setting	1 = 8 2 = 888°C 3 = 888°F 4 = 8.888 5 = 8.88 6 = 8.8	1
General settings			
4	Measurement update in seconds	0.5...10.0	1.0
5	Zero point setting (plus-/minus area in which zero is displayed)	0...100	1
Security settings			
50	Programming lock	0000...9999	0000
51	Release code	0000...9999	0000
Linearisation			
100	Number of sampling points	0...30	0
101...130	Sampling points programming	-999...9999	0
Information			
200	Serial number	0...9999	0

### Programme number functions

- PN 0 Either for the standard input signal setting 4-20mA or the display with self programmed input signal
- PN 1 This programme number defines the display at 20mA or the max value of the input signal
- PN 2 This programme number defines the display at 4mA or the min value of the input signal
- PN 3 This parameter sets the number of decimal places shown in the display

## NT 10

- PN 4 This sets the measurement update time.
- PN 5 This sets the range in which a zero reading will be provided (for example caused by false echoes)  
 The value relates to PN2 setting.
- PN 50 Access to the set up parameters is only possible, when the same access code for PN 51 has been entered in PN50. When an access code is in use, PN51 will always jump to PN50D.
- PN 51 Programming of the access code for use in PN50.
- PN 100 This parameter allows a linealisation of the measurement area to be programmed. The number of sampling points in addition to PN1 and PN2 can be programmed.
- PN 101 to PN 130 These additional sampling points are programmed via the input signal. That means that upcoming input signals are programmed according to the desired value.

### Example

Sampling point PN	Distance in m	Input signal in mA	Display before correction in %	Desired display is programmed in %
2	0	4,4	3	0
101	1,5	6,64	16	15
102	3	8,96	31	30
103	4	11,36	45	40
104	5	13,12	48	50
105	6	15,76	63	65
1	9	20,00	100	100

### Diagramm

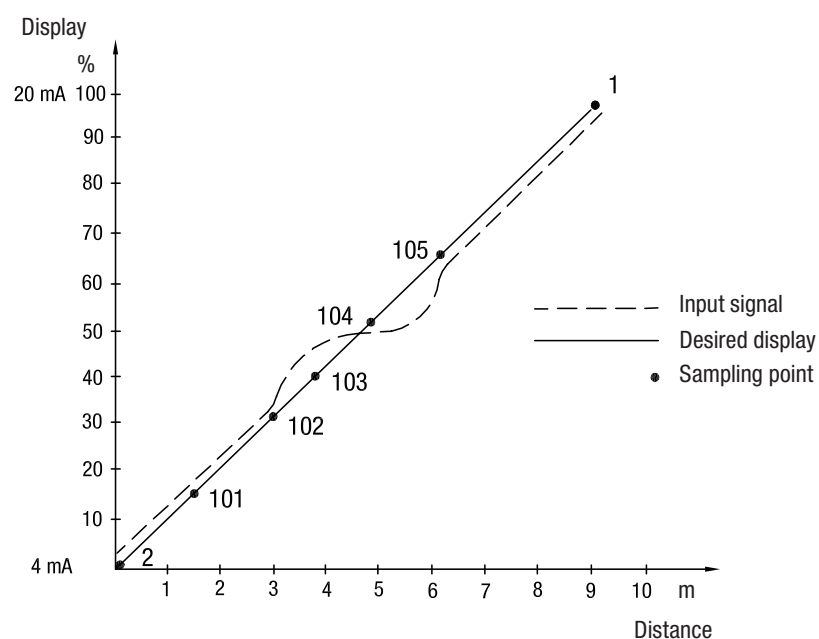

## NT 10

### Technical data

<b>Dimensions</b>	NT 10-1	
	Housing	48mm x 24mm x 42mm incl. mounting
	Cut-out dimensions	45.0 <sup>+0.6</sup> mm x 22.2 <sup>+0.3</sup> mm
	NT 10-2	
	Housing	72mm x 36mm x 43mm incl. mounting
	Cut-out dimensions	68.0 <sup>+0.7</sup> mm x 22.0 <sup>+0.6</sup> mm
	Mounting	snap in sealing
<b>Input</b>	Housing material	PC/ABS blend. black colour, UL94V-0
	Protection class	Front IP54, connections IP00
	Elect. connection	Terminal board on the rear up to 1.5mm <sup>2</sup>
	Measurement range	4-20 mA
<b>Accuracy</b>	Input resistance	Ri at 20 mA < 280 Ohm
	Resolution	-999 to +9999 Digits
	Measurement error	+/-0.2% of measurement area, +/- 1 digit
<b>Display</b>	Temp. coeff.	120 ppm/K
	Display	7 Segment LED, 10mm (Housing 48mm x 24mm) or 14mm (Housing 72mm x 36mm), red
	Overflow / Underflow	4 decimal places = display 9999 digits
<b>Memory</b>	Display time	cross beam above / cross beam below
	parameter saving	0.5 ... 10 s adjustable
<b>Operating conditions</b>	Data preservation	EEPROM
	Operating temperature	> 100 years
	Storage temperature	0 to +60°C
<b>EMC</b>		-20°C to +80°C
	EN61326-1 (1997) A1, A2	
<b>Electrical safety</b>		
	EN61010-1 (1998) A1, A2	

### Trouble shooting

1. The display is not working.

- Check the current loop.
- If it is OK, then the fault can only be repaired by the supplier ( faulty meter)

2. "HELP" is shown on the display

- The NT 10 has a fault in the configuration memory. It must be reset to the factory settings and then newly configured.
- Reset:
  1. Turn off the current loop power supply.
  2. Press P button and hold down.
  3. Switch on the current loop (minimum of 10mA) and press P button for approximately 2 s.

## NT 20

The NT 20 is used for the evaluation of the normal signals 0..10 V, 0..20 mA or 4..20 mA of the level sensors.  
 The 4 digit display shows the level on a 7 segment display

### Operation

The NT 20 is configured using 3 buttons.



Programme button P:

The programme button P accesses the programme mode and executes the various functions in programme mode.

Arrow DOWN button (minus button):

The arrow DOWN button is used for adjustment of the parameters.

Arrow UP button (plus button):

The arrow UP button is used for adjustment of the parameters.  
 functions in programme mode.

### Mounting

The user and display elements are on the front. The NT 20 is fixed in place with clamp screws. The terminal block for electrical wiring is on the back.

The NT 20 is intended for mounting on the control panel. Before fitting, the panel cut-out must be prepared according to the dimensions and tolerances shown in the technical data.

Before inserting the instrument, the mounting screws must be unclamped. Insert the instrument into the panel and then replace the screws. Hold the NT 20 in place and screw in by hand so that it is flush against the panel.  
 To remove the NT 20 follow the above steps in the reverse order.

### Electrical connection

Electrical connection is on the rear of the NT 20. A separate supply voltage is required and it not possible to be powered via a current loop.

#### Wiring plan

Clamp	Function	Clamp	Function
1	Input signal 10V	11	Relay S1 NO
2	Input signal 0/4-20mA	12	Relay S1 NC
3	Input signal 0V	13	Relay S1 COM
4-7	Not in use	14	Supply voltage -
8	Relay S2 NO	15	Supply voltage +
9	Relay S2 NC		

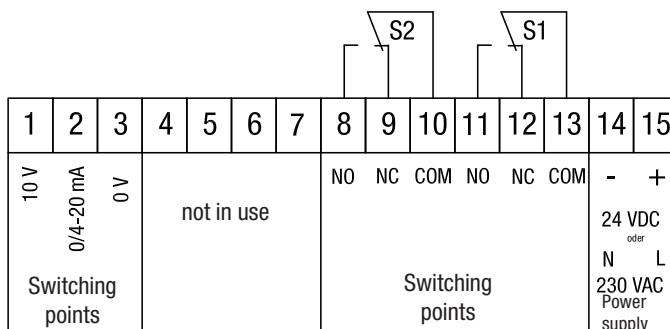

## Programming steps

To change into programming mode

Press the P button for the first programme number PNO

To change between the programme numbers

Press the P button and the arrow UP button to show the range of PNO to PN68.

To show the programmed value in the programme number

Once the required programme number is shown in the display, press the arrow UP or DOWN button to shown the programmed value

To change the programmed value

Follow the steps above to display the value. The first digit to the right will flash.

Use the UP and DOWN buttons to change to the required value. Press P and then the second digit from the right will flash.

Repeat as before until all digits have been set. Then press P for 1 second to save the new value. For a brief moment the NT 20 will show dashes in the display.

After approximately 7 seconds the NT12 will return to operating mode.

## Table of the programme numbers

PN	Function	Value range	Factory setting
Input			
0	Type of measurement signal	0 = Programming of the display over the max and min vlaues of the input signal 1 = 0 - 10V 2 = 0 - 20mA 3 = 4 - 20mA	0
1	Display by 10V, 20mA or max value of the input signal	-999...9999	2000
2	Display by 0V, 0mA, 4mA or min value of the input signal	-999...9999	0
3	Decimal place setting	use arrow UP for the required number	no decimal places
4	Measurement update time in seconds	0.1...10.0	1.0

## NT 20

Switching point relay S1			
61	Switching threshold based on the display value	-999...9999	500
62	Hysteresis based on the display value	0...9999	1
63	Mode 0 = EN 1 = DEN	0 / 1	1
Switching point relay S2			
66	Switching threshold based on the display value	-999...9999	1500
67	Hysteresis based on the display value	0...9999	1
68	Mode 0 = EN 1 = DEN	0 / 1	1

### Programme number functions

- PN 0 Defines whether input signal 1 - 3 is to be used or if the display is to be programmed with the input signal
- PN 1 This programme number defines the display at 0V, 20mA or the max value of the input signal
- PN 2 This programme number defines the display at 0V, 20mA or the min value of the input signal
- PN 3 This parameter sets the number of decimal places shown in the display
- PN 4 This sets the measurement update time.
- PN 61 -63 and PN 66 - 68 switching threshold, hysteresis, EN / DEN

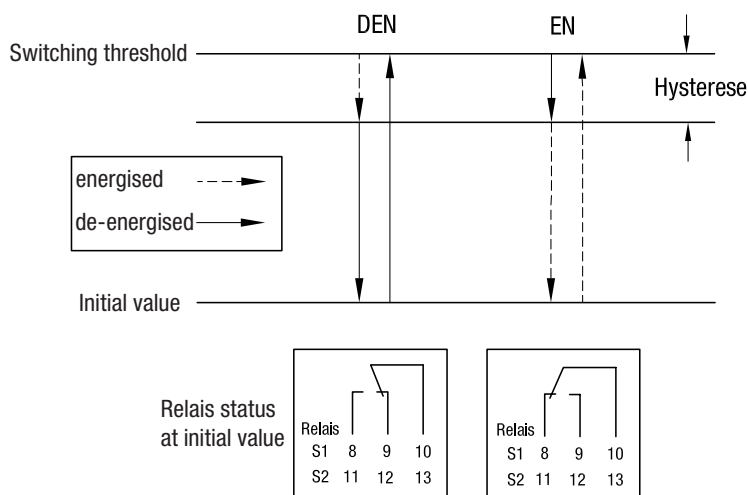

The hysteresis is freely programmable for each switching point. The function DEN activates the respective relay when the switching threshold is reached. In the function EN the respective relay is released when the switching threshold is reached. The function EN can be used for example to signal an alarm when there is a power supply outage.

### Programming lock

There are 2 jumpers on the back of the NT 20. These can be used to set a programming lock.

Variation 1: Unlimited programming possible.  
 The programmer can access all PNs.

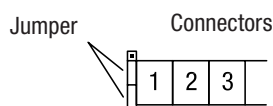

## NT 20

Variation 2: Programming is locked.  
 The programming mode is blocked.

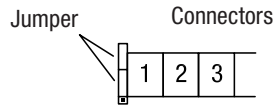

### Technical data

<b>Dimensions</b>	Housing	96mm x 24mm x 134mm incl. screw elements	
	Cut-out dimensions	92.0 <sup>+0.8</sup> mm x 22.0 <sup>+0.6</sup> mm	
	Mounting	snap in screw element	
	Housing material	PC/ABS blend, black colour, UL94V-0	
	Protection class	Front IP40; connections IP00	
	Elect. connection	Screw clamps on the back up to 2.5mm <sup>2</sup>	
<b>Input</b>	Measurement range	0-10 V, 0-20 mA, 4-20 mA	
	Input resistance	Ri at 10 V =100kOhm, 20 mA =100 Ohm	
<b>Output</b>	Relays S1 and S2		
	Change over contact	240 VAC / 0,25 A and 24 VDC / 1 A; resistive load	
	Switching cycle	2 x 10 <sup>5</sup> at max. contact load; 10 x 10 <sup>6</sup> mechanical	
<b>Accuracy</b>	Resolution	-999 bis +9999 digits	
	Measurement error	+/- 0.2% of measurement area, +/- 1 digit	
	Temp. coeff.	100 ppm/K	
<b>Supply voltage</b>	Voltage	NT 20-1:	230 VAC +/- 10% 50-60 Hz
		NT 20-2:	24 VDC +/- 10%
	Power drain	max. 5 VA	
<b>Display</b>	Display	7 Segment LED, 10mm high, red; 4 decimal places = display 9999 digit	
	Overflow / Underflow	cross beam above / Cross beam below	
	Display time	0.1 ... 10 s adjustable	
<b>Memory</b>	Parameter saving	EEPROM	
	Data preservation	> 30 years	
<b>Operating conditions</b>	Operating temperature	0 to +60°C	
	Storage temperature	-20°C to +80°C	
<b>EMC</b>	EN61326-1 (1997) A1, A2		
<b>Electrical safety</b>	EN61010-1 (1998) A1, A2		

### Trouble shooting

1. The display is not working.

- Check the power.
- If it is ok, then the fault can only be repaired by the supplier ( faulty meter)

2. "HELP" is shown on the display

- The NT 20 has a fault in the configuration memory. It must be reset to the factory settings and then newly configured.
- Reset:
  1. Turn off the power supply.
  2. Press P button and hold down.
  3. Switch on the power and press P button for approximately 2 s.

## NT 30

The NT 30 is used for the fill level display of counter impulse input signals such as the electromechanical SLS Lot. The 4-digit display shows the level on a 7 segment display

### Operation

The NT 30 is configured using 3 buttons.



**Programme button P:** The programme button P accesses the programme mode and executes the various functions in programme mode.

**Arrow DOWN button (Minus button):** The arrow DOWN button is used for adjustment of the parameters.

**Arrow UP button (plus button):** The arrow UP button is used for adjustment of the parameters functions in programme mode.

### Mounting

The user and display elements are on the front. The NT 30 is fixed in place with clamp screws. The terminal block for electrical wiring is on the back.

The NT 30 is intended for mounting on the control panel. Before fitting, the panel cut-out must be prepared according to the dimensions and tolerances shown in the technical data.

Before inserting the instrument, the mounting screws must be unclamped. Insert the instrument into the panel and then replace the screws. Hold the NT 30 in place and screw in by hand so that it is flush against the panel. To remove the NT 30 follow the above steps in the reverse order.

### Electrical connection

Electrical connection is on the rear of the NT 30. A separate supply voltage is required and it not possible to be powered via a current loop.

#### Wiring plan

Clamp	Function	Clamp	Function
1	Counter impulse (SLS 3000)	7	Switching point S2
2	Reset impulse (SLS 3000)	8	Switching point S2
3	Not in use	9	GND
4	+12 VDC	10	supply voltage -
5	Switching point S1	11	supply voltage +
6	Switching point S1		

### Electrical connections of the signal input of the UWT-Lot SLS 3000

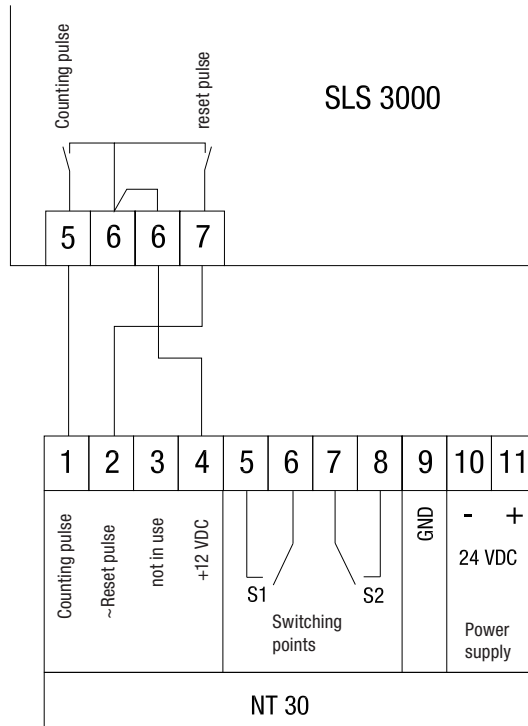

### Programming steps

To change into programming mode

Press the P button for the first programme number PNO

To change between the programme numbers

Press the P button and the arrow UP button to show the range of PNO to PN73.

To show the programmed value in the programme number

Once the required programme number is shown in the display, press the arrow UP or DOWN button to show the programmed value

To change the programmed value

Follow the steps above to display the value. The first digit from the right will flash  
 Use the UP and DOWN buttons to change to the required value. Press P and then the second digit from the right will flash.  
 Repeat as before until all digits have been set. Then press P for 1 second to save the new value. For a brief moment the NT 30 will show dashes in the display.

After approximately 7 seconds the NT 30 will return to operating mode.

## NT 30

### Table of programme numbers

PN	Function	Value range	Factory setting	with SLS 3000
1	Polarity of the input 0 = climbing / npn 1 = falling / pnp	0 / 1	0	0
2	Counter operation 0 = normal impulse counter without filter 1 = Filter >30Hz Other operations available on request	0	0	1
3	Scaling function 0 = subtracting/adding (dependant on PN 9) Function 1 and 2 are not relevant for contents measurement	0 / 1 / 2	0	0
4	Scaling factor	1...9999	1	Programme desired display
5	Decimal place setting	use arrow UP for the required number	no decimal place	Programme desired display
6	Reset to start value mode 0 = none 1 = UP button 2 = Reset input Reset 3 = Reset button or input Mode 4 - 7 not relevant for contents measurement	0 - 7	3	2 or 3
7	Reset handling 0 = static 1 = shoulder triggered	0 / 1	0	0
8	Counter start value	0000...max.	1000	Programme desired display
9	Counting directing 0 = count up 1 = count down	0 / 1	0	1
50	Programming lock	0000...9999	0000	Dependant on PN 51
51	Release code	0000...9999	0000	Programme desired display
<b>Programming of switching points S1 and S2</b>				
60/S1 70/S2	Level limit function 0 = deactivated 1 = standard signal output Function 2 is not relevant for contents measurement	0 / 1 / 2	0	Programme required function
61/S1 71/S2	Switching threshold	0000...max.	1000	Programmed required threshold
62/S1 72/S2	Decay time in ms	0...100	0	0
63/S1 73/S2	Operation type 0 = EN when > threshold 1 = DEN when > threshold	0 / 1	1	Programme required function

### Programme number functions

PN 1	This parameter defines the shoulder which is used to evaluate a level input as logic 1.
PN 2	This parameter sets the operation type. 0 is for standard impulse counting. In setting 1, frequencies over 30 Hz are not counted. Therefore mechanical contacts are ignored.
PN 3	This is used to set how the scaling factor in the calculation of the display result works. The scaling factor is either subtracted or added to each impulse, dependant on PN9.
PN 4	The scaling factor is programmed here. This depends on whether the display is in height, weight or volume.
PN 5	This parameter is used to set the number of decimal places.
PN 6	The reset mode can be set to determine which incident returns the counter to the start value.
PN 7	This programme number is used to determine the handling of the reset signal. For static evaluations the counter remains at 0 for the duration of the incident. For evaluations of the shoulder, the counter will be reset to 0 with the respective shoulder change and then counting will immediately continue.
PN 8	This sets the start value of the counter.
PN 9	This sets the counting direction. With counting up the display value that has been programmed in PN 3 / 4 incrementally increases and conversely with counting down, it will be incrementally decreased.
PN 50	Access to the set up parameters is only possible, when the same access code for PN 51 has been entered in PN50. When an access code is in use, PN51 will always jump to PN50D.
PN 51	Programming of the access code for use in PN50.
PN 60 / 70	This parameter sets whether switch S1 and S2 are deactivated or are used for a level limit function. Dependant on the operation type, the digital output will either be switched on or switched off when the switching threshold is exceeded.
PN 61/ 71	This programmes the switch threshold for the digital output switching.
PN 62 / 72	This programmes the decay time of the digital output signal
PN 63 / 73	This programmes the logic of the digital output. By 1, S1 and S2 are turned on when the threshold value of PN 61 / 71 is exceeded. By 0, S1 and S2 are turned off when the threshold value of PN 61 / 71 is exceeded.

## NT 30

### Technical data

<b>Dimensions</b>	Housing	72mm x 36mm x 103mm incl. screw elements
	Cut-out dimensions	68.0 <sup>+0.7</sup> mm x 33.0 <sup>+0.6</sup> mm
	Mounting	Snap in screw element
	Housing material	PC/ABS blend, black colour, UL94V-0
	Protection class	Front IP54; connections IP00
	Elect connections	Screw clamps on the back up to 2.5mm <sup>2</sup>
<b>Input</b>	Impulse rate	10.000 Impulse / s max 30 Impulses / s be active damping
	Input resistance	approx 5 kOhm
	Input voltage	+5...24V
	High- / Low level	>=3V / <2V
<b>Output</b>	Switching point	30 VAC / 0.4 A - 30 VDC / 0.4 A
	Photo Mosfet	Input / output strength 100 VAC
<b>Power</b>	Voltage	230 VAC +/- 10% 50-60 Hz 24 VDC +/- 10%
	Power drain	max. 5 VA
<b>Display</b>	Display	7 segment LED, 14mm high, red 4 digits = display 9999 digits
<b>Memory</b>	Parameter saving	EEPROM
	Data preservation	> 30 years
<b>Operating conditions</b>	Operating temperature	0 bis +60°C
	Storage temperature	-20°C bis +80°C
<b>EMC</b>	EN61326-1 (1997) A1, A2	
<b>Electrical safety</b>	EN61010-1 (1998) A1, A2	

### Trouble shooting

1. The display is not working.

- Check the power.
- If it is ok, then the fault can only be repaired by the supplier ( faulty meter)

2. "HELP" is shown on the display

- The NT 30 has a fault in the configuration memory. It must be reset to the factory settings and then newly configured.
- Reset:
  1. Turn off the power supply.
  2. Press P button and hold down.
  3. Switch on the power and press P button for approximately 2 s.

3. Overflow- / Underflow characteristics.

- When there is an overflow of the counter (when counting up), then all digits are shown with a flashing 9  
This error can only be reset by resetting the counter.
- When there is an underflow of the counter (when counting down), then all digits are shown with a flashing 0  
It is not possible to display negative values.

## NT 40

The NT 40 is a coil meter that is used to show the fill level in percentage. The input signal is 4-20 mA.



### Mounting

The user and display elements are on the front. The NT 40 is supplied with mounting elements in place with a plastic seal. The terminal block for electrical wiring is on the back.

The NT 40 is intended for mounting on the control panel. Before fitting, the panel cut-out must be prepared according to the dimensions and tolerances shown in the technical data.

### Electrical connection

Electrical connection is on the rear of the NT40. The NT40 does not require its own power supply.

#### Wiring plan

Clamp	Function
1	signal input +
2	signal input -

### Technische Daten

<b>Dimensions</b>	NT 40-1	
	Housing	72mm x 72mm x 38.5mm incl screw elements
	Cut-out dimensions	68.0 <sup>+0.3</sup> mm x 68.0 <sup>+0.3</sup> mm
	NT 40-2	
	Housing	96mm x 96mm x 60mm incl screw elements
	Cut-out dimensions	92.0 <sup>+0.3</sup> mm x 92.0 <sup>+0.3</sup> mm
	Mounting	Snap in clamp elements
	Housing material	PC/ABS bend, UL94V-1
	Protection class	Front IP52; connection IP00
	Elect connection	Terminal board on the rear
<b>Input</b>	Measurement range	4 - 20mA
	Internal resistance	10 Ohm
<b>Operating conditions</b>	Operating temperature	-25°C to +40°C
<b>Accuracy</b>	Class 1.5	1.5% of end value
<b>Display</b>	Scale	0 - 100 (corresponds to 4-20 mA), needle deflection 90°