

Table of contents

	Page
Safety notes / Technical support	G2

Applications / Overview	G3

Function	G4

Transducer selection guide	G5

Evaluation overview	G6

Technical data	
Dimensions	G7
Electrical Data / Electronic	G9
Mechanical Data	G10
Operating conditions	G11
Approvals	G11

Accessories	G12
Options	G15

Mounting	G16

Electrical installation	
Safety Instructions	G18
Connection NW 1000 to NW 2001	G19
Power supply, 4-20mA, Relay output	G20
Avoid of Cross Talking of multiple Transducers	G23
Nivowave PC-converter	G24
Modbus network	G25
Profibus DP	G27

Fieldbus Software	G27

Notes for use in Hazardous Locations	G29

Subject to technical change.
 We assume no liability for typing errors.

Different variations than specified are possible.
 Please contact our technical consultants.

Safety notes / Technical support

Notes

- Installation, maintenance and commissioning may be accomplished only by qualified technical personnel.
- The product must be used only in the manner outlined in this instruction manual.

Special attention must be paid to warnings and notes as follows:



WARNING

Relates to a caution symbol on the product: A failure to observe the necessary precautions can result in death, serious injury and/or considerable material damage.



WARNING



A failure to observe the necessary precautions can result in death, serious injury and/or considerable material damage.

This symbol is used, when there is no corresponding caution symbol on the product.

CAUTION

A failure to observe the necessary precautions can result in considerable material damage.

Safety symbols

In manual and on product	Description
	CAUTION: refer to accompanying documents (manual) for details.
	Earth (ground) Terminal
	Protective Conductor Terminal

Technical support

Please get in contact to your local supplier (address see under uwt.de). Otherwise you can contact:

UWT GmbH
 Westendstr. 5
 D-87488 Betzigau

Tel.: 0049 (0)831 57123-0
 Fax. 0049 (0)831 76879
info@uwt.de
www.uwt.de

Applications / Overview

The Nivowave is a non intrusive acoustic wave measurement system. It is used for level monitoring of solids and liquids.

It can be delivered with ATEX approval for use in Hazardous Locations.

The Nivowave system is normally mounted at the top of the silo or tank.

A selection of fields of applications and industries:

• **Water / Waste water:**

Inlet screens, sumps, pump stations, water towers, dam level, chemical, open channel flow etc.

• **Mining:**

Crushers, surge bins, ore passes, conveyor profile, blocked chute, stockpile, stackers, reclaimers, storage silos etc.

• **Powers stations:**

Boiler bunkers, raw coal bunkers, ash pits, fly ash silos, etc.

• **Food**

• **Plastics**

• **Chemicals**

• **Irrigation**

• **Cement**

• **Grain**

• **Paper**

• **Quarries**

Level measurement in solids

Standard Series

with horn for high performance in complex solid applications

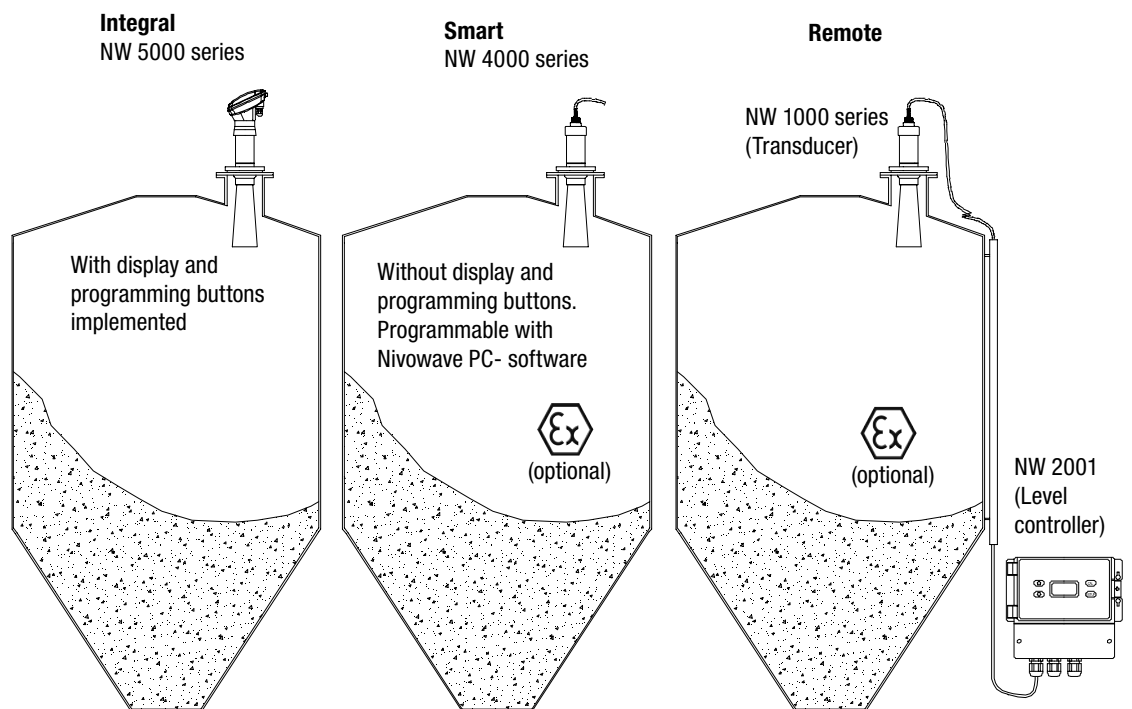

Light series

without horn for easy solid measurements in small vessels

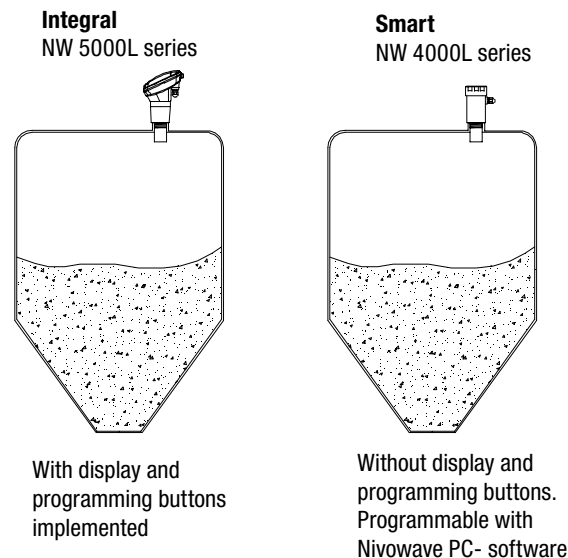

Overview / Function

Level measurement in liquids

Light series
 without horn for
 normal liquid
 applications

Integral
 NW 5000L series

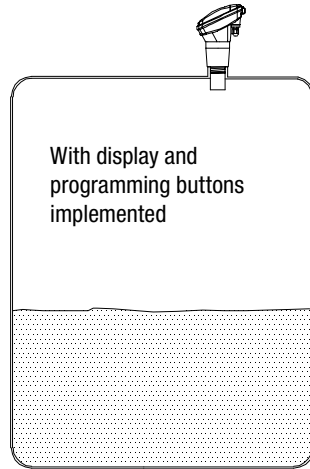

Smart
 NW 4000L series

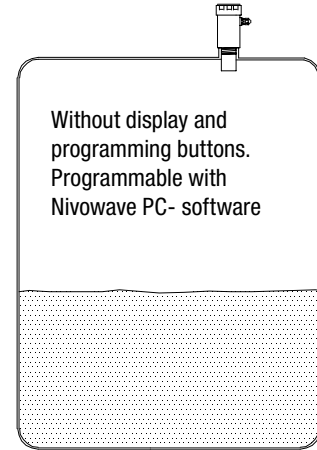

Standard Series
 with horn for high
 performance in
 complex liquid
 applications

Integral
 NW 5000 series

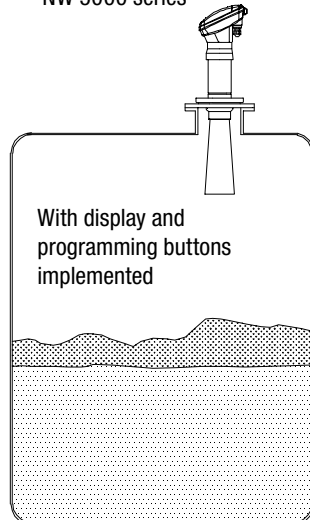

Smart
 NW 4000 series

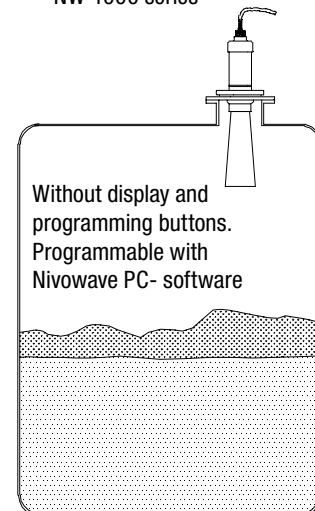

Function

The Nivowave emits a high powered acoustic wave transmit pulse which is reflected from the surface of the material being measured.

The reflected signal is processed using specially developed software to enhance the correct signal and reject false or spurious echoes.

The transmission of these high powered waves ensures minimal losses through the environment where the sensor is located. Due to the high powered emitted pulse, any losses have a far less effect than traditional ultrasonic devices.

More energy is transmitted hence more energy is returned.

The receiver circuitry is designed to identify and monitor low level return signals even when noise levels are quite high.

The measured signal is temperature compensated to provide maximum accuracy to the outputs and display.

Advantages

- Large selection of transducers.
- No contact between the transducer and the material.
- Suitable for measuring many different applications.
- Easy to calibrate and commission.

Transducer Selection guide

Transducer selection by applications

The following graphic is a guideline for the selection of the right transducer depending on the application. Anyway it is recommended to contact the local distributor to ensure a proper transducer selection fitting to the individual application.

Liquids	waveless	x	o			
	rippy		x	o		
Solids	granular			x	o	
	powder			x		o
Degree of difficulty		1	2	3	4	5

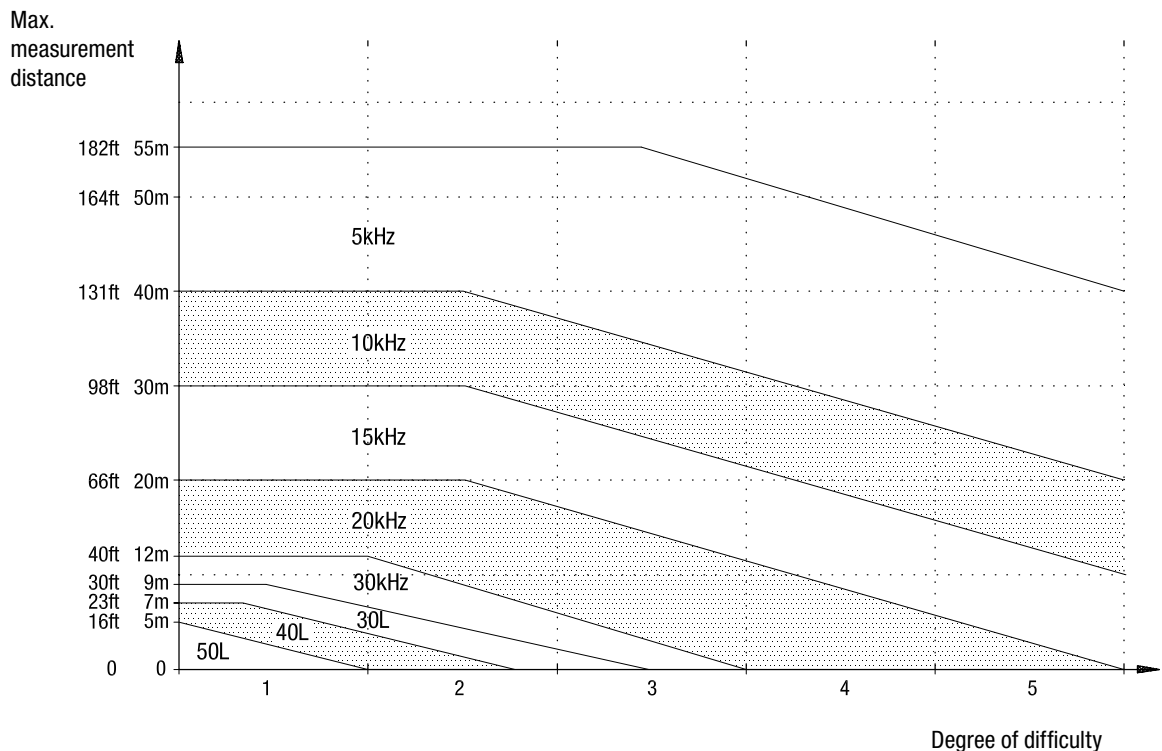

Note: x Normal measurement
 o Measurement also during filling process or with strongly absorbent surface (e.g. cellulose, wood chips, foil snippet, foam formation)
 Measurement distance >55m (182 ft) on request

Transducer ratings

		Frequency	Min. Blanking Distance	Measurement Accuracy at ideal conditions (of adjusted range)	Beam Angle	Number of pulses per minute		
						3/4-Wire 24V DC / 230V AC	2-Wire 4mA	2-Wire 20mA
Light Series	NW ...50L	50kHz	0,25 m (10")	+/- 0,25%	7.5°	180	30	100
	NW ...40L	40kHz	0,30m (12")	+/- 0,25%	7.5°	180	30	100
	NW ...30L	30kHz	0,35m (14")	+/- 0,25%	7.5°	180	30	100
Standard Series	NW30	30kHz	0,35 m (14")	+/- 0,25%	6°	180	30	100
	NW20	20kHz	0,45m (17")	+/- 0,25%	6°	130	18	70
	NW15	15kHz	0,60m (24")	+/- 0,25%	6°	90	8	40
	NW10	10kHz	1,0m (39")	+/- 0,25%	6°	50	3	22
	NW05	05kHz	1,5m (59")	+/- 0,25%	6°	40	0,75	14

Evaluation overview

Signal interface

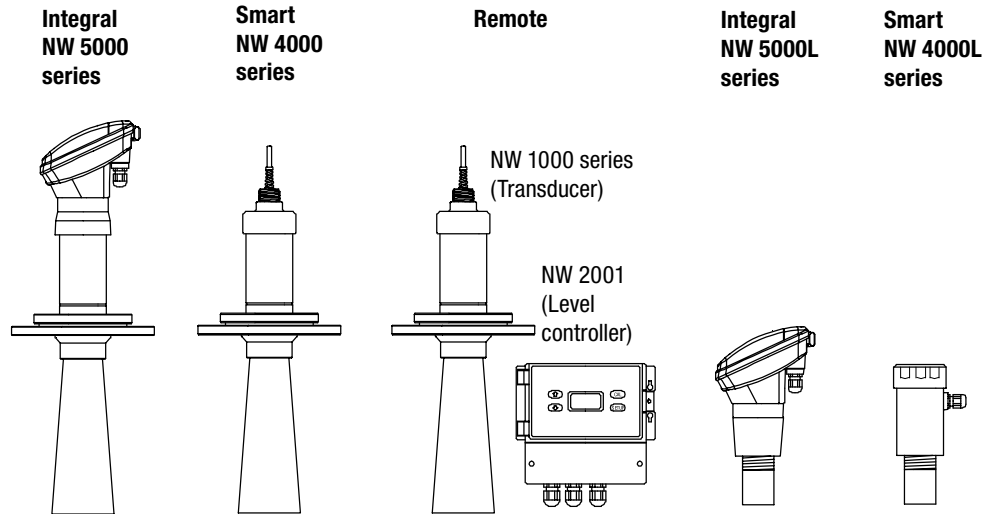

4-20mA active	•			•	•	
4-20mA passive	•	•		•	•	•
4-20mA HART	•			•	•	
Modbus	•	•		•	•	•
Profibus DP ⁽¹⁾				•		

(1) Note: Available as GSD file; Read Only of measurement value

Remote control

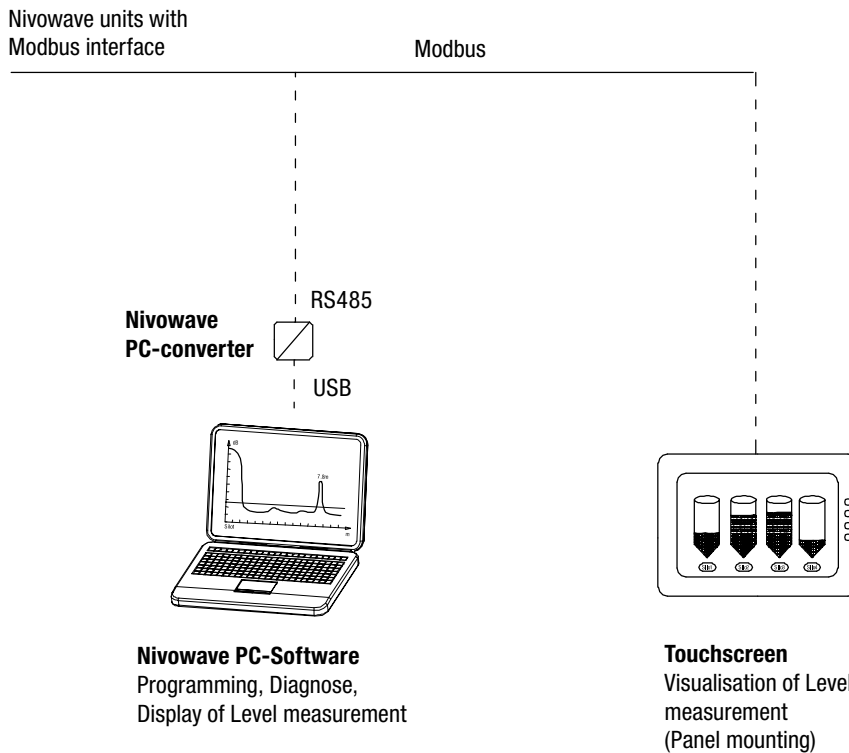

Technical Data

Dimensions

Standard series

Integral NW 5000 series

Smart NW 4000 series Remote NW 1000 series

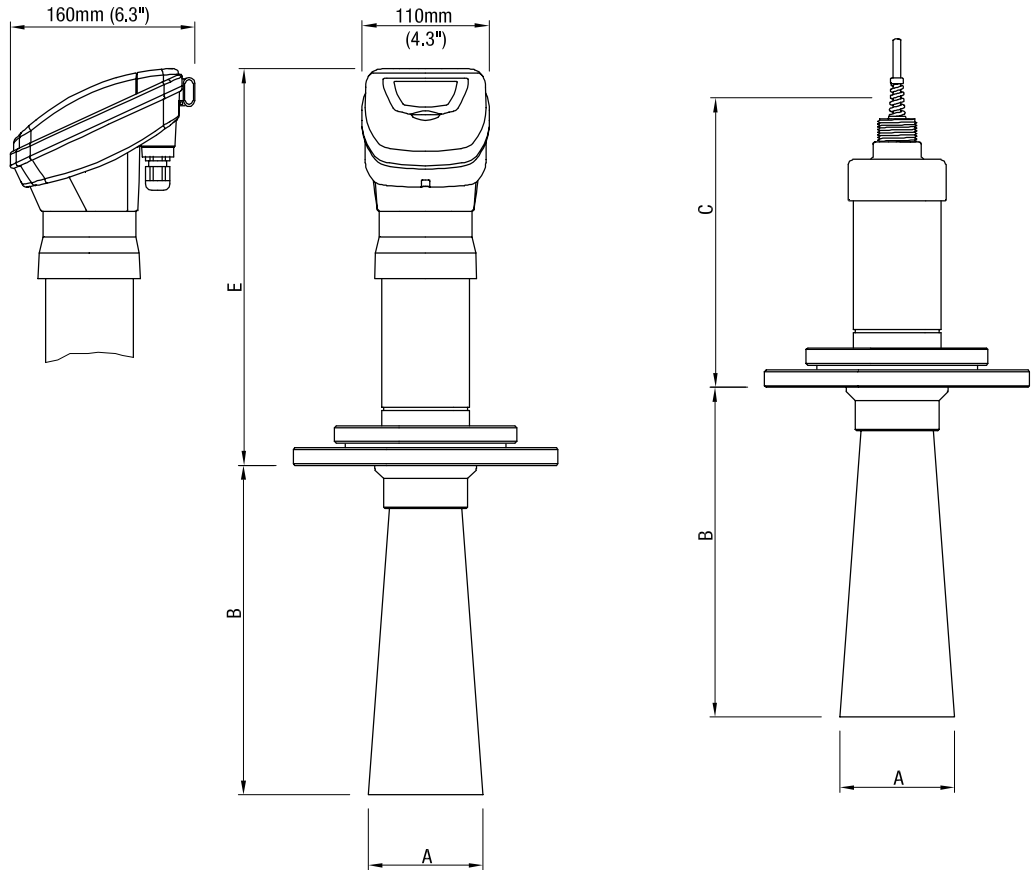

Integral NW 5000 series	Smart NW 4000 series	Remote NW 1000 series	Selected Flange	A		B		C		E	
				mm	inch	mm	inch	mm	inch	mm	inch
NW 5030	NW 4030	NW 1030	DN100 / 4"	98.5	3.9	260	10.2	260	10.2	350	13.8
NW 5020	NW 4020	NW 1020	DN100 / 4"	98.5	3.9	260	10.2	300	11.8	390	15.4
			DN150 / 6"	98.5	3.9	260	10.2	300	11.8	390	15.4
NW 5015	NW 4015	NW 1015	DN150 / 6"	195 (1)	7.6 (1)	280	11.0	350	13.8	440	17.3
			DN200 / 8"	195	7.6	280	11.0	350	13.8	440	17.3
			DN250 / 10"	236	9.2	415	16.3	350	13.8	440	17.3
NW 5010	NW 4010	NW 1010	DN200 / 8"	195	7.6	280	11.0	450	17.7	540	21.3
			DN200 / 8"	236 (1)	9.2 (1)	415	16.3	450	17.7	540	21.3
			DN250 / 10"	236	9.2	415	16.3	450	17.7	540	21.3
NW 5005	NW 4005	NW 1005	DN200 / 8"	236 (1)	9.2 (1)	415	16.3	750	29.5	840	33.1
			DN250 / 10"	236	9.2	415	16.3	750	29.5	840	33.1

Note: (1) Flexible polyurethan horn is used, which can be folded together to fit in the mounting nozzle.

Technical data

Dimensions

Light series

Integral NW 5000L series

Smart NW 4000L series

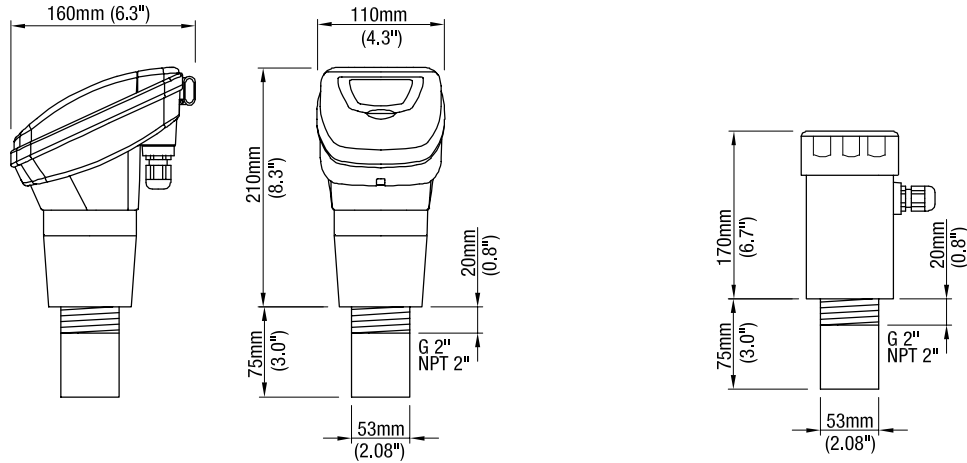

Level controller NW 2001

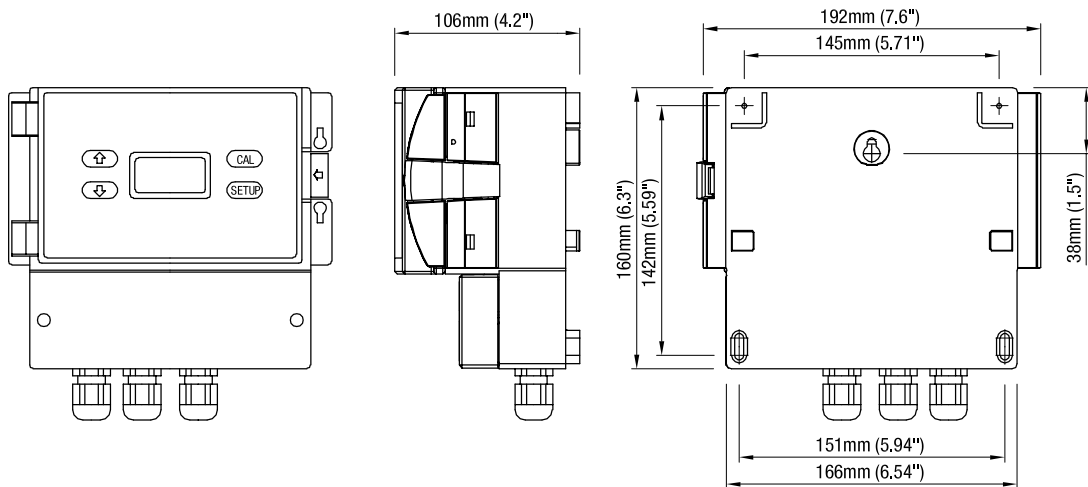

Flanges

NW flanges fitting to	Lk		D		d2		Holes number
	mm	inch	mm	inch	mm	inch	
DN100 PN16	180	7.0	220	8.7	18	0.7	8
DN150 PN16	240	9.4	285	11.2	22	0.85	8
DN200 PN16	295	11.6	340	13.4	22	0.85	12
DN250 PN10	350	13.8	395	15.6	22	0.85	12
4" 150bs ANSI	190.5	7.5	228	9.0	19	0.75	8
6" 150bs ANSI	241	9.5	279.5	11.0	22	0.85	8
8" 150bs ANSI	298.5	11.8	343	13.5	22	0.85	8
10" 150bs ANSI	362	14.3	406	16.0	25	1.0	12

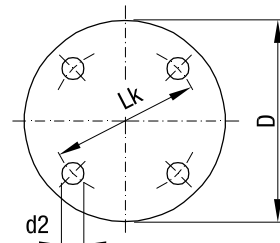

Technical data

Electrical data

Connection terminals	max. 1.5mm ² (AWG 14)	
Cable entry	NW 2001:	2 pieces M20 x 1.5 srewed cable gland and 2 pieces blind plug
	NW 4000L series,	1 piece M20 x 1.5 srewed cable gland
	NW 5000, NW 5000L series,	2 pieces M16 x 1.5 srewed cable gland and 1 piece blind plug
	NW 9000:	2 pieces M20 x 1.5 srewed cable gland
Extension cables for Remote Transducer and Modbus	Specifications see in chapter "Electrical installation". Suggested cable types see in chapter "Accessories".	
Extension cables for Profibus DP	Use common recommended Profibus cables	
Protection class	I	
Installation category	II	
Pollution degree	2	

Electronic

	2-wire version	3/4-wire version
Supply voltage	NW 2001, NW 5000, NW 5000L series: 12 - 30V DC (max. ripple = 100mV) NW 4000, NW 4000L series: 9 - 24V DC (max. ripple = 100mV) All voltages incl. 10% of EN 61010	NW 2001, NW 5000, NW 5000L series: 12 - 30V DC (max. ripple = 100mV) 90 - 260V 50/60Hz (option) NW 4000, NW 4000L series: 9 - 24V DC (max. ripple = 100mV) All voltages incl. 10% of EN 61010
Installed load	max. 0,6W	max. 10W at 24V DC max. 10VA at 240V AC
Signal output 4-20mA	max. 750 Ohms (at 24V DC supply voltage)	max. 750 Ohms (passive, at 24V DC supply voltage) max. 500 Ohms (active)
Signal output Relay	no relais available	5x SPDT (NW 2001) 1x SPST (NW 4000, NW 4000L series) 2x SPDT (NW 5000, NW 5000L series) Relay SPDT: max. 250V AC, 0.5A, 125VA, non inductive max. 220V DC, 0.27A, 60W Relay SPST: max. 30V DC, 0.5A, non inductive
Communication HART 4-20mA	HART Rev 5 Baud Rate = 1200 Device number range 0-15 (selectable in menu) Voltage range: 24V DC Typical load: 250 Ohms	same as for 2-wire version
Communication Modbus		Physical layer: RS 485 and Ground Mode: RTU, Modbus type: Slave Device number range: 1 - 255 (selectable in menu) Baudrate: 19200 Baud, Data bits: 8, Stop Bits: 1 Parity: None Multi-drop configuration possible

Technical data

Communication Profibus DP		Physical layer: RS 485, isolated Type: Slave Device number range: 0 - 126 (selectable in menu) Baudrate: 9.6 kbps to 12 Mbps
		Available communication by GSD file, Read only
Display	LCD display: 2 line x 8 digit (no display for Smart NW 4000, NW 4000L series)	LCD display: 2 line x 8 digit (no display for Smart NW 4000, NW 4000L series)
Indicating light		Status of relais by build in LED
Memory	Non-volatile (no backup battery required) > 10 years data retention	Non-volatile (no backup battery required) > 10 years data retention
Isolation		AC Power supply to any output: 3000Vrms DC Power supply to any output*: 500Vrms * Modbus is not isolated against DC power supply.

Mechanical data

Electronic Housing	NW 2001: NW 5000, NW 5000L series:	Material: Plastic PC Colour: RAL 7035 grey Material: Plastic Valox 357U Colour: RAL 5010 gentian blue
Transducer body	NW 1000, NW 4000, NW 4000L, NW 5000, NW 5000L series:	Housing material: Plastic Polypropylen (for ATEX: polypropylen / aluminium) Colour: RAL 7035 grey
Transducer face	Standard series NW 1000, NW 4000, NW 5000 series, depending on selected model: Light series NW 4000L, NW 5000L series:	Polyolfin version for dry/ condensed atmosphere, max +70°C (+158°F) Teflon version for dry/ wet/ steamy atmosphere, max. +85°C (+185°F) Titanium version for dry/ wet/ steamy atmosphere, max +150°C (+302°F) Tefzel for dry/ wet/ steamy atmosphere, max. +85°C (+185°F)
Process connection	Standard series NW 1000, NW 4000, NW 5000 series: Flange material: Flange type:	Polypropylen version for 70°C (158°F) and 85°C (185°F) Carbon version for 150°C (302°F) DIN or ANSI according to selection
	Light series NW 4000L, NW 5000L series:	Tefzel
Horn	Standard series NW 1000, NW 4000, NW 5000 series: Horn material:	Polypropylen or PUR version for 70°C (158°F) and 85°C (185°F) Carbon version for 150°C (302°F)
Ingress protection	Standard series: NW 2001: NW 1000, NW 4000 series: NW 5000 series: Light series: NW 4000L, NW 5000L series:	IP 65 (EN 60529), NEMA 4X IP 67 (EN 60529) IP 67 (EN 60529) IP 67 (EN 60529)

Technical data

Overall weight (ca.)	NW 2001:	1kg (2.2lbs)			
	NW 1000, NW 4000 series:	Transducer (without flange / horn)		Flange incl. horn	
		NW 1030, NW 4030	2kg (4.4 lbs)	DN100 PN16	0.8kg (1.8lbs)
		NW 1020, NW 4020	2.5kg (5.5 lbs)	DN150 PN16	1.8kg (4.0lbs)
		NW 1015, NW 4015	10kg (21 lbs)	DN200 PN16	2.8kg (6.2lbs)
		NW 1010, NW 4010	10kg (21 lbs)	DN250 PN16	3.6kg (8.0lbs)
		NW 1005, NW 4005	15kg (33 lbs)	4" 150lbs	0.8kg (1.8lbs)
				6" 150lbs	1.8kg (4.0lbs)
				8" 150lbs	2.8kg (6.2lbs)
				10" 150lbs	3.6kg (8.0lbs)
	NW 5000 series:	Housing with Transducer (without flange / horn)		Flange incl. horn	
		NW 5030	3kg (6.6 lbs)	DN100 PN16	0.8kg (1.8lbs)
		NW 5020	3.5kg (10 lbs)	DN150 PN16	1.8kg (4.0lbs)
		NW 5015	12kg (25 lbs)	DN200 PN16	2.8kg (6.2lbs)
		NW 5010	12kg (25 lbs)	DN250 PN16	3.6kg (8.0lbs)
		NW 5005	17kg (36 lbs)	4" 150lbs	0.8kg (1.8lbs)
				6" 150lbs	1.8kg (4.0lbs)
				8" 150lbs	2.8kg (6.2lbs)
				10" 150lbs	3.6kg (8.0lbs)
	NW 4000L series:	2kg (4.4 lbs)			
	NW 5000L series:	3kg (6.6 lbs)			

Operating conditions

Ambient temperature (housing, outside process)	All series:	-40 .. +70°C (-40 .. +158°F) -20 .. +70°C (-4 .. +158°F) ATEX version
Process temperature	Depending on selected model:	
	NW 1000 series:	-40°C (-40°F) .. +70°C (158°F) / 85°C (185°F) / 150°C (302°F) -20°C (-4°F) .. +70°C (158°F) / 75°C (167°F) ATEX version
	NW 4000, NW 5000 series:	-40°C (-40°F) .. +70°C (158°F) / 85°C (185°F) -20°C (-4°F) .. +70°C (158°F) / 75°C (167°F) ATEX version NW 4000
	NW 4000L, NW 5000L series:	-40°C (-40°F) .. +85°C (185°F)
Max. process overpressure	NW 1000, NW 4000, NW 5000 series:	100mbar (1.5psi)
	NW 4000L, NW 5000L series:	1bar (15psi)
Relative Humidity	0-100%, suitable for outdoor use	
Altitude	max. 2.000m (6.562ft)	

Approvals

General purpose	CE	EN 61010-1
Hazardous Locations (optional)	ATEX	Dust Explosion ATEX II 1 D and 1/2D Ex tD A20/21 IP67 T85°C
EMC	EN 61326 -A1	

Pressure Equipment Directive (97/23/EC) The units are not subject to this directive, because they are classified as „pressure-keeping equipment“ and do not have a pressurized housing (see Art.1, Abs. 2.1.4).
 The unit is NOT intended for use as a “equipment part with safety function (Art.1, Abs. 2.1.3).
 If the units should be used as „equipment part with safety function, please contact the manufacturer.

Accessories

Nivowave PC-Software

- PC Software for
- Programming
 - Diagnose
 - Display of Level measurement

Connection via RS 485 (Modbus) to PC.
To connect the PC, use the Nivowave PC-Converter

More detailed information:
See external manual of Nivowave PC-Software

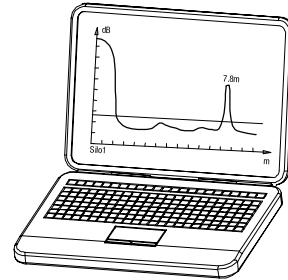

Nivowave PC-Converter

USB to RS 485 (Modbus) converter

Connects a PC via USB to the Modbus output of series NW 2001, NW 4000, NW 4000L, NW 5000 and NW 5000L.

It works as a Modbus Master.
It is used mainly for programming and diagnose of the Nivowave units. It provides no galvanic isolation between USB and RS485.

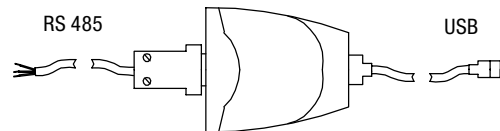

Accessories

Overview of mounting accessories

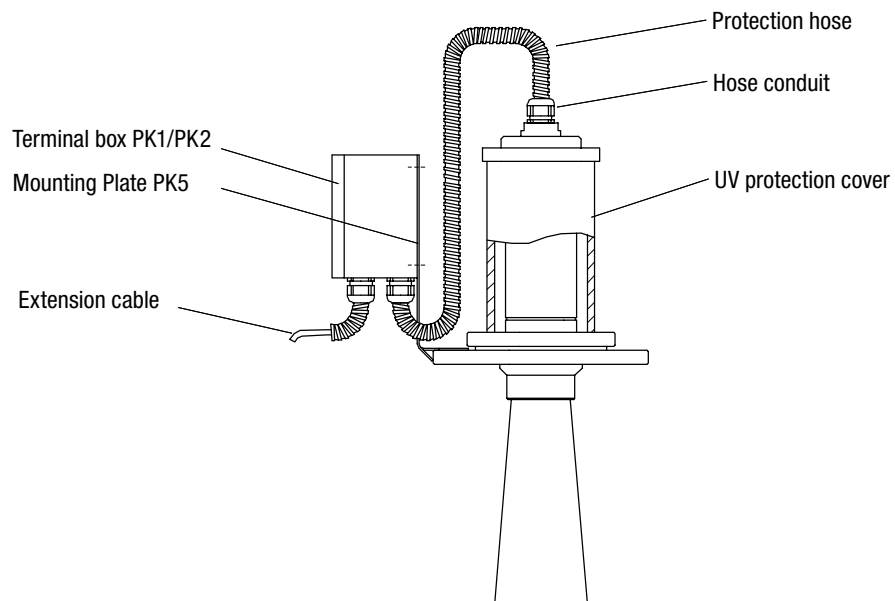

Terminal Box PK1

For extension of the connection cable of NW 1000, NW 4000, NW 4000L series.

Terminals integrated
 Cable glands 2 pieces M16x1.5 + 1 blind plug
 Including Mounting Plate PK5

Ingress protection IP 65
 Ambient temperature: -20°C .. + 60°C (-4°C .. 140°F)
 Dimensions
 PK1: 130mm x 130mm (5.1" x 5.1")
 PK1 ATEX: 160mm x 160mm (6.3" x 6.3")

Version PK1 ATEX for installation in ATEX Zone 21
 Certificate: ATEX II 2D Ex tD A21 IP65 T80°C

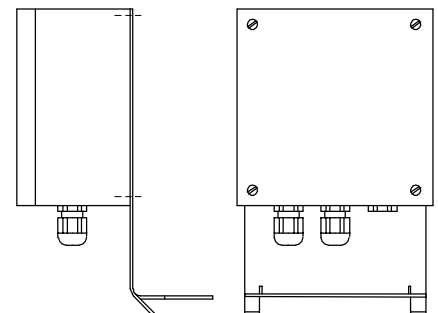

Modbus Terminal Box PK2

For installing a Modbus network with the Nivowave units

Terminals integrated
 Cable glands 3 pieces M16x1.5 + 1 blind plug

Ingress protection IP 65
 Ambient temperature: -20°C .. + 60°C (-4°C .. 140°F)
 Dimensions:
 PK2: 130mm x 130mm (5.1" x 5.1")
 PK2 ATEX: 160mm x 160mm (6.3" x 6.3")

Version PK2 ATEX for installation in ATEX Zone 21
 Certificate: ATEX II 2D Ex tD A21 IP65 T80°C

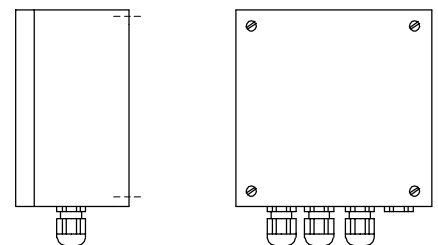

Accessories

Cabeling system:

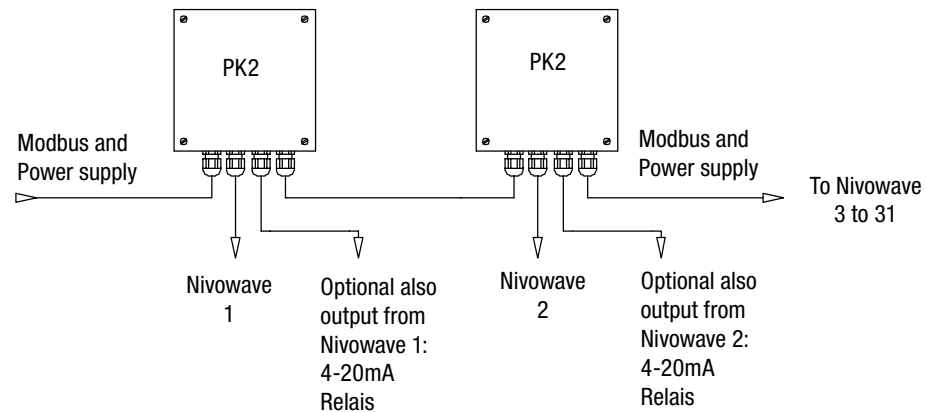

Mounting Plate PK5

Used for mounting the Terminal box PK2 directly on the flange of the transducers

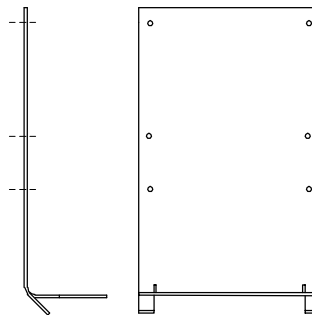

Extension cables / cable protection

- For extending the cables of the Transducer NW 1000 series and Smart NW 4000, NW 4000L series
- For wiring a Modbus network
- Notes for choosing the right cable see chapter "Electrical Installation"
- It is generally recommended to protect PVC signal cables from UV influence by installing them in pipes

Shielded cable

Cross section 0,34mm² (AWG22)
 Capacitance 120nF/km (between wires) / 160nF/km (wire to shield)
 Common shield
 -30°C (-22°F) to 80°C (176°F), PVC (LiYCY)
 Available with 10 wires

Twisted pair cable

4 conductor twisted pair instrument cable
 Each twisted pair has a separate shield plus one common shield
 One twisted pair: cross section 0,33mm² (AWG22), used for Power Supply line
 One twisted pair: cross section 0,2mm² (AWG24), used for A/B line
 Impedance 120 Ohms
 Capacitance 40nF/km (between twisted pair wires)
 -10°C (14°F) to 80°C (176°F), PVC

Protection hose

For installation of transducer cable or modbus cable in ATEX Zone 21

Threaded hose coupling

With thread M16x1.5. Fitting with protection hose. Applicable for ATEX Zone 21

UV protection cover

For installation of ATEX transducers in the sun
 With connection thread M16x1,5 for mounting the threaded hose coupling

Mounting kit

Sealings, screws and washers for fixing the unit on a flange.

Accessories / Options

Modbus Biasing Network PK6

Stabilizer for Modbus communication.
 Supports the needed Biasing voltages to ensure a proper function in a network with long installed cables.
 Implements the needed termination resistor for the beginning of the Modbus network.

To be connected to 24V DC supply voltage.

DIN Rail mounting. Can be placed in the PK2 Terminal box or in a cabinet.

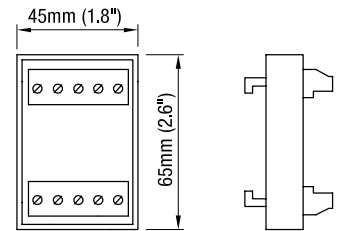

Modbus Termination Resistor PK7

120 Ohms resistor for the end of the Modbus network.

DIN Rail mounting.
 Can be placed in the PK2 Terminal box.

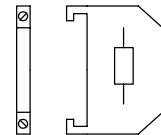

Modbus Terminal Clamps PK8

Used for wiring a Modbus network inside the terminal compartment of the NW 2001.

Dimensions: 14x17x20mm (0.55x0.67x0.79")
 1 Set includes 5 terminals (needed for one NW 2001)

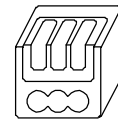

Option: Aiming kit

For aiming the Transducer in the application.

Necessary only in case of wrong echoes caused by ladders, beams and other fixtures in the vessel.
 Normal measurement of solids does NOT require aiming to the material angle of repose.

The Aiming kit is optional available to the straight Transducer fixing, which is delivered as standard.

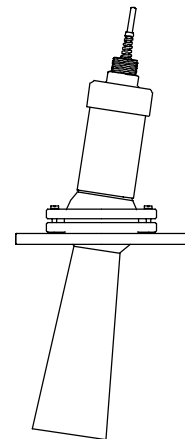

Mounting

! General Safety Instructions

Process pressure	Improper installation may result in loss of process pressure.
Chemical resistance against the medium	Materials of construction are chosen based on their chemical compatibility (or inertness) for general purposes. For exposure to specific environments, check with chemical compatibility charts before installing. Do not put into service where there is a possibility of contact with acetic acid.
Environment and installation conditions	Environment and installation conditions should be checked regularly
Industrial conditions	This equipment is designed for use in normal industrial conditions relating to humidity, vibration, etc. If the user intends to operate the equipment in more severe environmental conditions, the manufacturer or local distributor should be consulted for advice.
Working temperature	The working must not exceed the operating temperature range stated in the technical data.
Mounting location	The right mounting place is significant for a proper function. Observe mounting instructions.
Flange mounting	A plastic sealing must be used to tighten the flange.

! Additional Safety Instructions for Hazardous Locations

Installation regulations	For devices to use in Hazardous Locations the respectively valid installation regulations must be observed.
UV	To prevent the effect of long term UV exposure, the transducers must be protected from direct sunlight.

Amplifier mounting

Mounting NW 2001	<ul style="list-style-type: none"> • Select a suitable mounting position that is not in direct sunlight. If necessary, utilize a sunshade. • Observe the minimum and maximum temperature limits. • Do not mount near sources of high E.M.F. such as high current cables, motor starters, or S.C.R. variable speed drives. • Avoid mounting in high vibration areas. If necessary, use rubber absorption mounts if mounting in light vibration areas.
-------------------------	--

Mounting

Transducer mounting

Mounting position

- Selecting a suitable position to mount the transducer on the vessel is the most important step. Please read the following installation guide and contact your representative if you have any doubts or questions.
- A clear line of sight from the transducer to the product being monitored is preferred.
- First priority is to keep the transducer away from fill pipes, ladders, beams etc.
- Normal measurement of solids does NOT require aiming to the material angle of repose. Aiming the Transducer to the material angle of repose is only in seldom cases necessary. It is required, if any ladders, beams etc cause wrong echoes. In this case, use the Aiming kit to blank these wrong echoes.

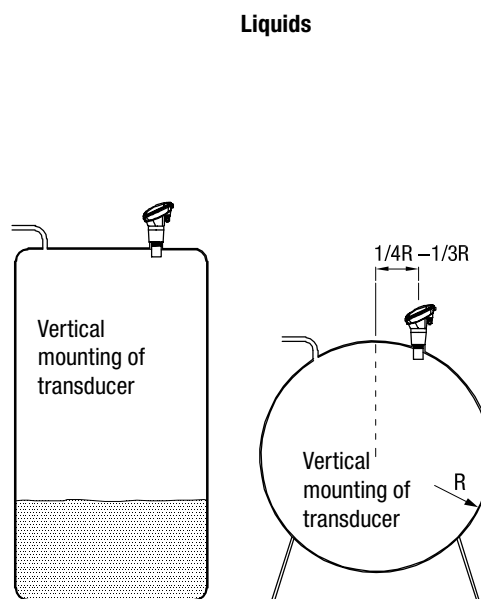
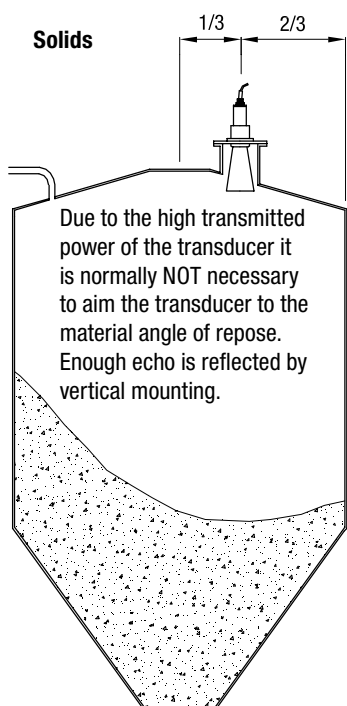

Distance to vessel roof

Standard series

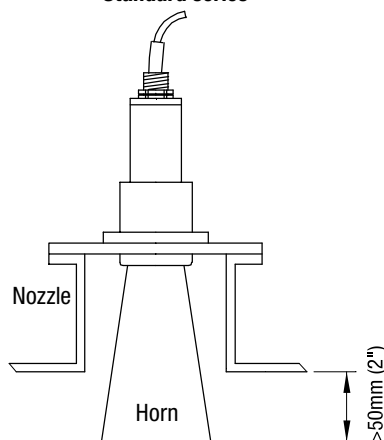

The horn must protrude at least 50mm (2") into the vessel.
 See in table on page G7 the dimension "B" of the horn.
 Use this value as a reference to define the max. height of the nozzle.

Light series

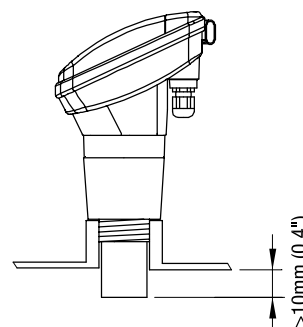

The face (membran) of transducer must extend at least 10mm (0.4") into the vessel.
 See dimension on page G8.

Mounting / Electrical installation

Blanking distance

- The transducer face must be at least the Blanking distance away from highest product level at all times.
- Increase the distance of the stated values by 50% if there is foam, dust, steam, or condensation in the vessel.

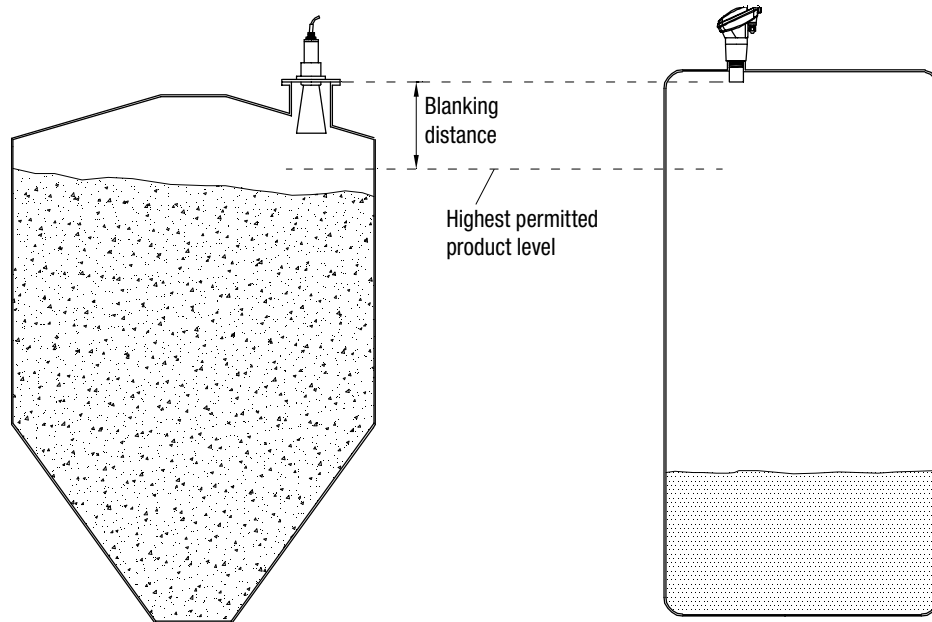

Standard series			
Integral NW 5000 series	Smart NW 4000 series	Remote NW 1000 series	Min. Blanking Distance
NW 5030	NW 4030	NW 1030	0.35 m (14")
NW 5020	NW 4020	NW 1020	0.45m (17")
NW 5015	NW 4015	NW 1015	0.60m (24")
NW 5010	NW 4010	NW 1010	1.0m (39")
NW 5005	NW 4005	NW 1005	1.5m (59")

Light series		
Integral NW 5000L series	Smart NW 4000L series	Min. Blanking Distance
NW 5050L	NW 4050L	0.25 m (10")
NW 5040L	NW 4040L	0.30m (12")
NW 5030L	NW 4030L	0.35m (14")

Electrical installation

! General Safety Instructions

Handling	In the case of inexpert handling or handling malpractice, the electric safety of the device cannot be guaranteed.
Installation regulations	The local regulations must be observed.
Fuse	Use a fuse to protect the power supply circuit and the output circuits.
RCCB protection	In the case of a defect, the distribution voltage must automatically be cut off by a RCCB protection switch so as to protect the user of the device from indirect contact with dangerous electric tensions.
Power supply switch	A voltage-disconnecting switch must be provided near the device.
Wiring diagram	The electrical connections are made in accordance with the wiring diagram.
Supply voltage	Compare the supply voltage applied with the specifications given on the name plate before switching the device on.
Cable gland	Make sure that the screwed cable gland safely seals the cable and that it is tight (danger of water intrusion). Cable glands that are not used have to be locked with a closing element.

Electrical installation

Field wiring cables	All field wirings must have insulation suitable for at least 250V AC. The temperature rating must be at least 80°C (176°F).
Connecting the terminals	Make sure that max. 8mm (0,31") of the pigtails are bared (danger of contact with live parts).
Relay protection	Provide protection for relay contacts as to protect the device against spikes with inductive loads.

! Additional Safety Instructions for Hazardous Locations

Installation regulations	For devices to use in Hazardous Locations the respectively valid installation regulations must be observed.
Cable glands	The used entry devices and blanking elements must have an adequate type approval and a temperature range of at least -20°C (-4°F) to +60°C (140°F). In addition they shall be suitable for the conditions and correctly installed. Where applicable the provided original parts of the manufacturer must be used.
Cables	To be compliant, the equipment must be installed with suitable protection for the cable. It must be protected in a suitable manner and terminated in an enclosure suitable for the environment. A pull relief must be provided for the cables, when the device is installed with the factory provided cable glands. Cables must only be replaced by the same cable type. If extending the cable, it must be protected in a junction box and terminated in an enclosure suitable for the environment.
Earthing	Where earth connection is present, the units must be earthed.
Wiring / Hardware configurations	Before making any wiring or hardware configuration changes, it is important to disconnect power from the equipment.

Connection NW 1000 to NW 2001

Connection Transducer

Recommended cables:

Cable length <50m (164 ft):

Cable length >50m (164ft) - 500m (1640ft):

Shielded cable (specifications see page G14)

Twisted pair cable (specifications see page G14)

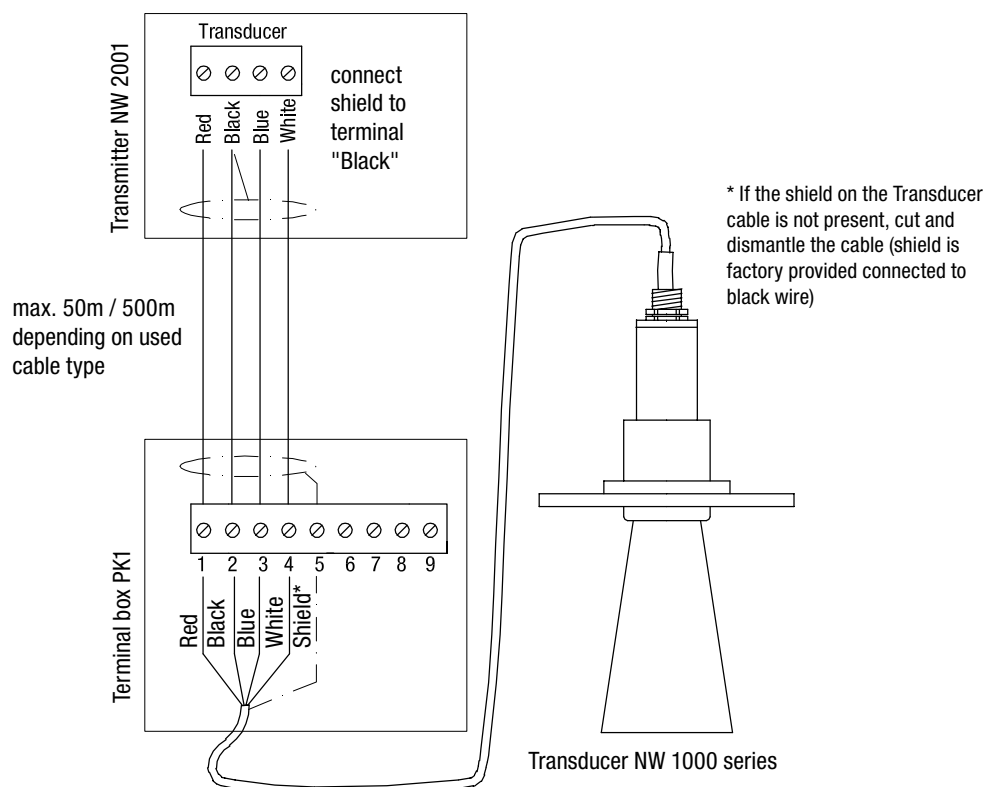

Electrical installation

NW 2001, NW 5000, NW 5000L series
 Power supply, 4-20mA output, Relay output

Power supply

3/4-wire

DC supply



+ -

+ -

12-30V DC

AC or DC supply
 depending on
 ordered version

AC supply



L1 N ⊕

L1 N ⊕

90-260V AC

max. 1.5mm²
 (AWG14)

Note:
 Terminal "DC-IN -" and
 "Earth" are internally
 connected

4-20mA output

2 wire
 2 wire HART
 3/4 wire
 3/4 wire HART

Active

(3/4 wire version)



- + Is

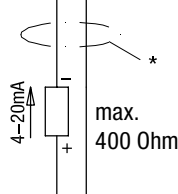

max.
 400 Ohm

Passive

(2 wire, 3/4 wire version)



- + Is

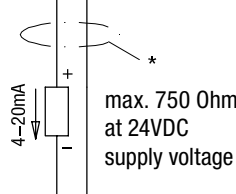

max. 750 Ohm
 at 24VDC
 supply voltage

Power supply
 12-30V DC

max. 1.5mm²
 (AWG14)

3/4 wire: Isolated
 output: can be made
 common with + or - of
 DC supply supply

* Use shielded
 cable. Connect
 shield to either DC-
 or Earth

Relay output

3/4 wire

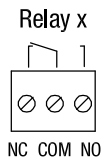

NC COM NO

Relay 1 to max. Relay 5
 (depending on selected version)

Independent programmable

Switching logic:

See description in the
 programming manual
 under "Output Adjustment
 Menu"

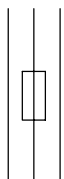

Fuse: max. 0,5A

max. 240V AC, 0,5A, 120VA, non inductive

Electrical installation

NW 4000, NW 4000L series
 Version with cable

Cable colours

Signal	DC IN		Comms		4-20mA		Relais		
Connection	+	-	B	A	-	+	COM	NO	TEST IN

Cable colour	Red	Black	Blue	White	Green	Yellow	Brown	Orange or pink	Purple
--------------	-----	-------	------	-------	-------	--------	-------	----------------	--------

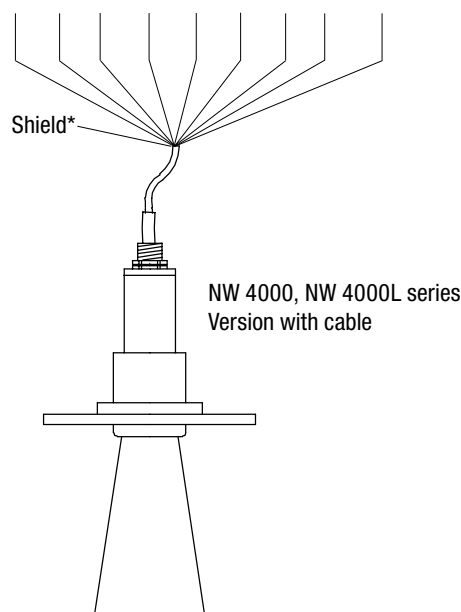

Cables are present according to the ordered version

* If the shield on the cable is not present, cut and dismantle the cable (shield is factory provided connected to black wire)

Cable extension with Terminal Box PK1

Recommended cables:

- If "Comms" connection is only used to program or diagnose the unit (no evaluation in a Modbus network): Shielded cable (specifications see page G14), max. cable length 50m (164ft)
- If "Comms" connection is used in a Modbus network for evaluation: Twisted pair cable (specifications see page G14), max. cable length 1000m (3270ft)

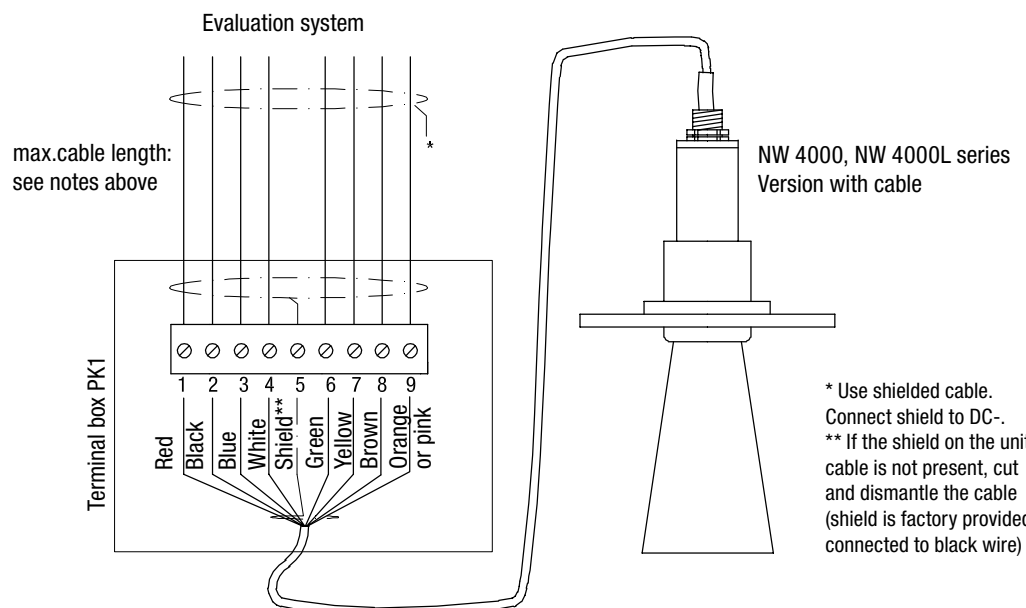

* Use shielded cable. Connect shield to DC-.
 ** If the shield on the unit cable is not present, cut and dismantle the cable (shield is factory provided connected to black wire)

Electrical installation

NW 4000, NW 4000L series

Power supply, 4-20mA output, Relay output

Power supply

3/4-wire

Version with junction box

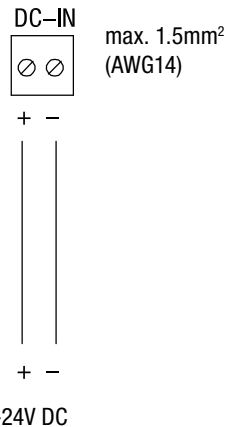

Version with cable

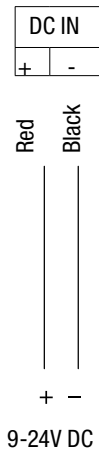

4-20mA output (passive)

2 wire
3/4 wire

Version with junction box

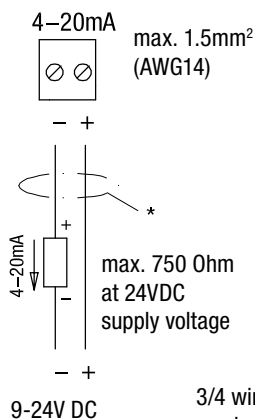

Version with cable

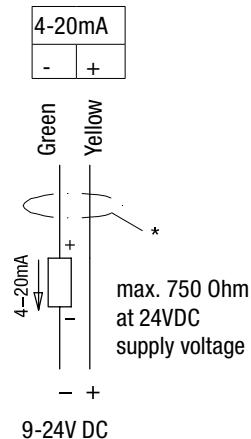

3/4 wire: Isolated output:
can be made common
with + or - of DC power
supply

* Use shielded
cable. Connect
shield to DC-

Relay output

3/4 wire

Version with junction box

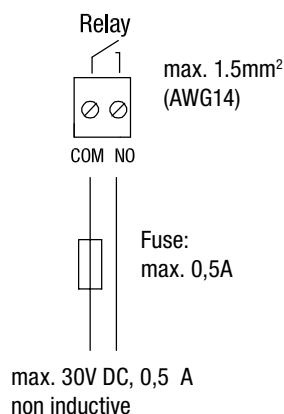

Version with cable

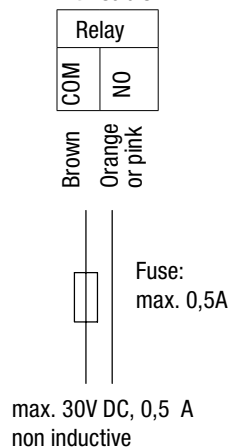

1 Relay
available

Electrical installation

NW 2001, NW 4000, NW 4000L, NW 5000, NW 5000L series
 Avoidance of Cross Talking of multiple Transducers

Cross Talking situation

When installing more than one Transducer in a silo, it can happen, that one Transducer influences the other, which can lead to a wrong measurement. To avoid this, following wiring and programming is recommended:

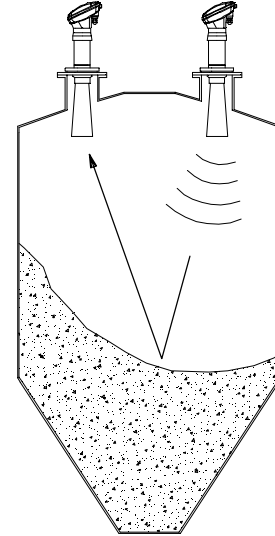

Wiring

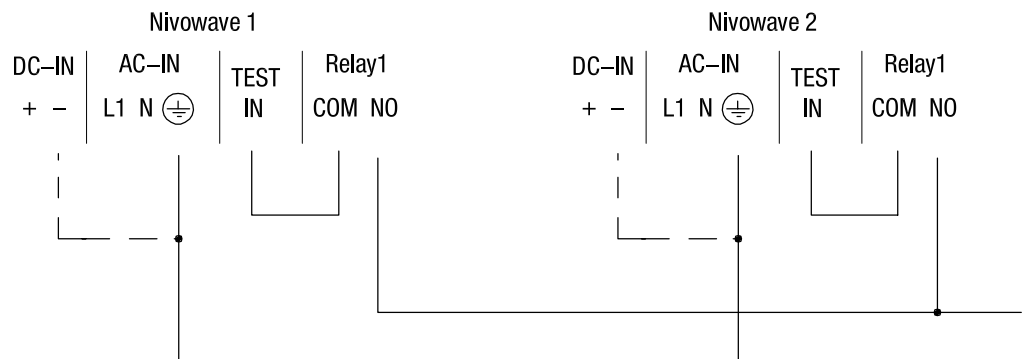

To reach a common ground for all Nivowaves, it is necessary either to connect all DC-IN - or all Earth terminals in parallel.

Note: DC-IN - and Earth are connected together inside the Nivowave.

Programming

In the software setup of each Nivowave (Output Adjust Menu), program Relay 1 to ,FS' (Failsafe) mode. You could use a different Relay number in the same way, if Relay 1 is needed for another function.

Function

TEST IN connection:

- While the Transducer is pulsing, the TEST IN connection is driven to 0V by this Nivowave.
 - While the TEST IN is set to 0V from outside (by another Nivowave), the Transducer will not pulse.
- The combination of these two functions avoid, that the Transducers can pulse at the same time. This means that no crosstalking can happen.

To reach this, it is necessary to connect the TEST IN terminals of the Nivowaves together.

Relay:

The Relay (programmed into Failsafe mode) is in line with the TEST IN connection.

The function of this is to prevent a possible lock up of the whole system if one Nivowave has a problem (such as power failure). Any time that a Nivowave is in the failed state, it will be disconnected by the Relay from the other Nivowaves, so they can continue working together.

Electrical installation

Nivowave PC-converter

Use of Nivowave PC-converter

The Nivowave PC-converter works as a Modbus Master. It is used mainly for programming and diagnose. Powers supply is supported through USB.

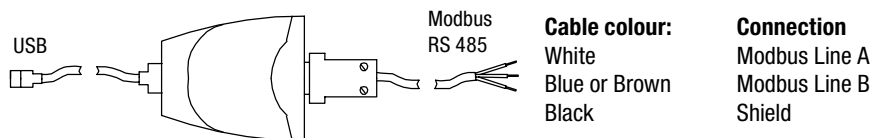

Connecting Nivowave PC-converter to a single Nivowave unit

CAUTION The converter is not isolated between USB and RS485 side. Take care, that the used PC or Laptop is galvanically isolated from Earth.

Connection without Biasing network

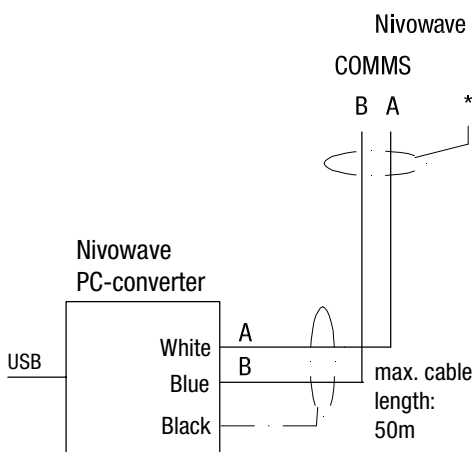

Connection with Biasing network PK6

In case of a unstable network the use of the Biasing network PK6 is recommended.

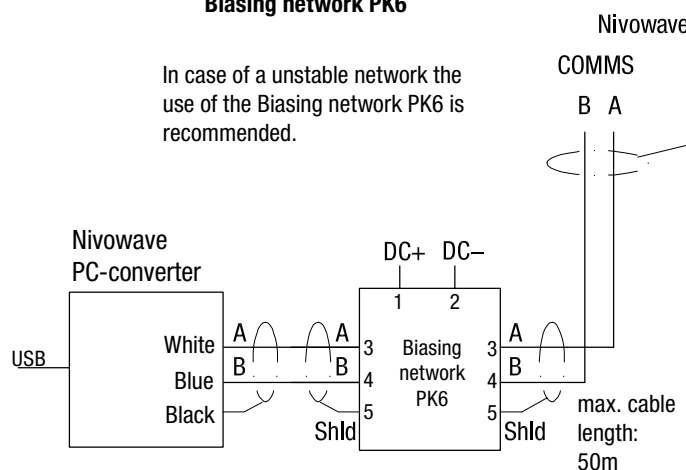

DC-, DC+ = 24V Supporting voltage for the Biasing network

* Connect shield to either "DC-IN -" or "Shld" or "Earth"

Connecting Nivowave PC-converter to a Modbus Network

CAUTION It should be avoided, that another Modbus Master is connected together with the Nivowave PC-converter. The converter is not isolated between USB and RS485 side. Take care, that the used PC or Laptop is galvanically isolated from Earth. For permant installation it is recommended to use a converter, which has a galvanic isolation implemented.

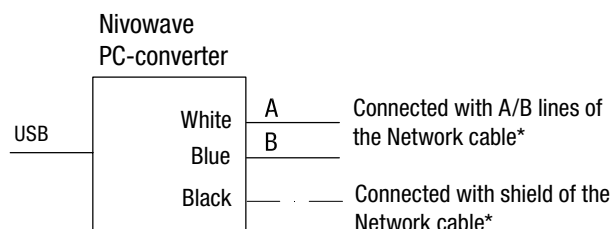

*See Modbus networks on page G23

Electrical installation

Modbus: Installing a Modbus Network

General note The mentioned line "A" is connected to Modbus line "D1", and line "B" to "D0".

Recommended cable for Modbus network Twisted pair cable (specifications see page G14)

Modbus and DC supply in the same cable

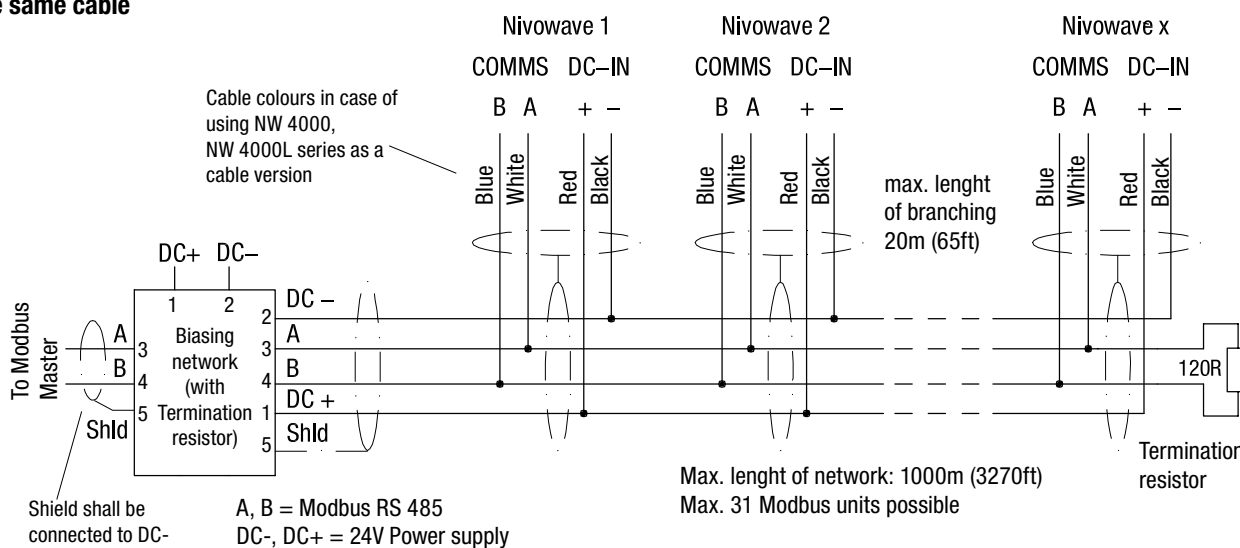

Additional use of 4-20mA output and Relay should be wired in a separate cable, not mixed with the Modbus network.

Note: Terminal "DC-IN -" and "Earth" are internally connected

Modbus in a separate cable

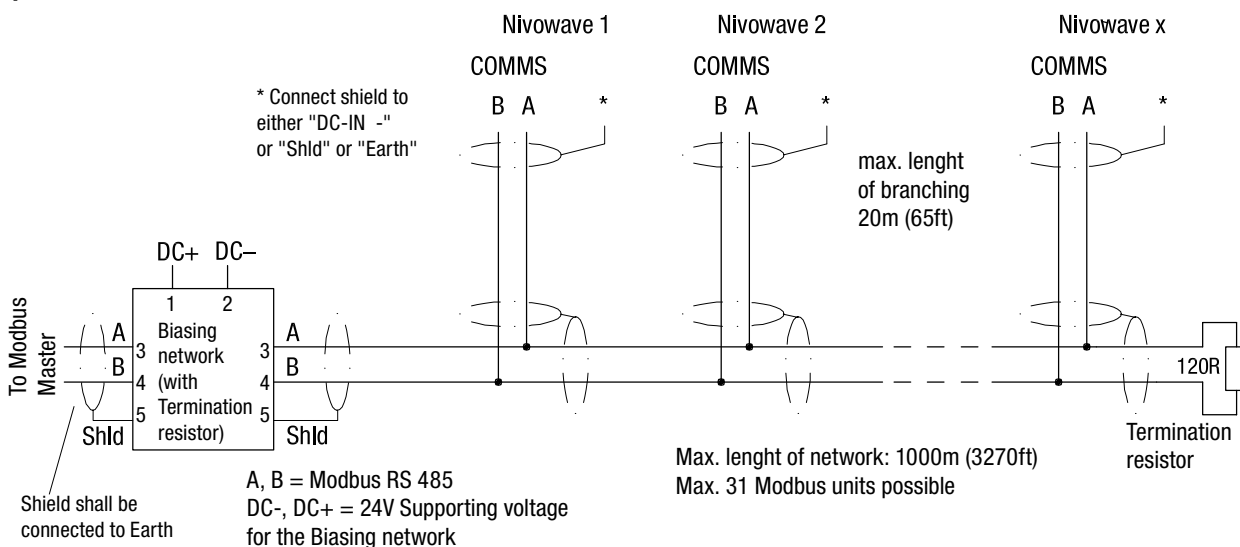

Additional use of 4-20mA output and Relay should be wired in a separate cable, not mixed with the Modbus network.

Electrical installation

Modbus: Accessories for a Modbus Network

Use of Biasing network PK6

PK6 is used to stabilize the Modbus network, if long cables are used. It implements also the needed Terminal resistor at the beginning of the network.

Required voltage: DC+/DC- 24V DC

The Biasing network with Terminal resistor can be part of a Modbus Master, or be a separate module.

The design or the values of the components can be different, when using other suppliers of a biasing network. It must be able to ensure a proper working voltage of ca. 300mV between A and B, if none of the connected Modbus units is talking.

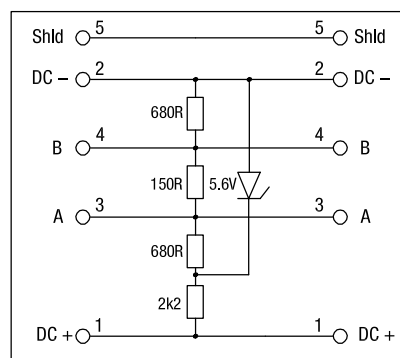

Biasing network PK6 with integrated Terminal resistor

Use of Terminal Box PK2

Termination resistor PK7 at the end of the Modbus network. To be connected to terminal 3 and 4.

Implementation on the Branching points of Modbus

Incoming Modbus cable

Outgoing Modbus cable

Modbus cable to Nivowave

Terminal: Connection

- 1 Power supply DC+
- 2 Power supply DC-
- 3 Modbus Line B
- 4 Modbus Line A
- 5 Modbus Shield

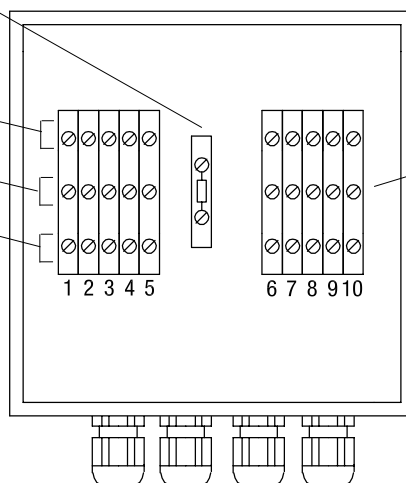

Terminals for cable-extension of the 4-20mA and Relay output from NW 4000 and NW 4000L series (cable version) additional to the Modbus connection:

Terminal: Connection

- 6 4-20mA -
- 7 4-20mA +
- 8 Relay COM
- 9 Relay NO
- 10 Free terminal

Use of Terminal clamps PK8

The terminal clamps PK8 enables safe and easy wiring of the Modbus cable inside the terminal compartment of NW 2001. No extra terminal box is required.

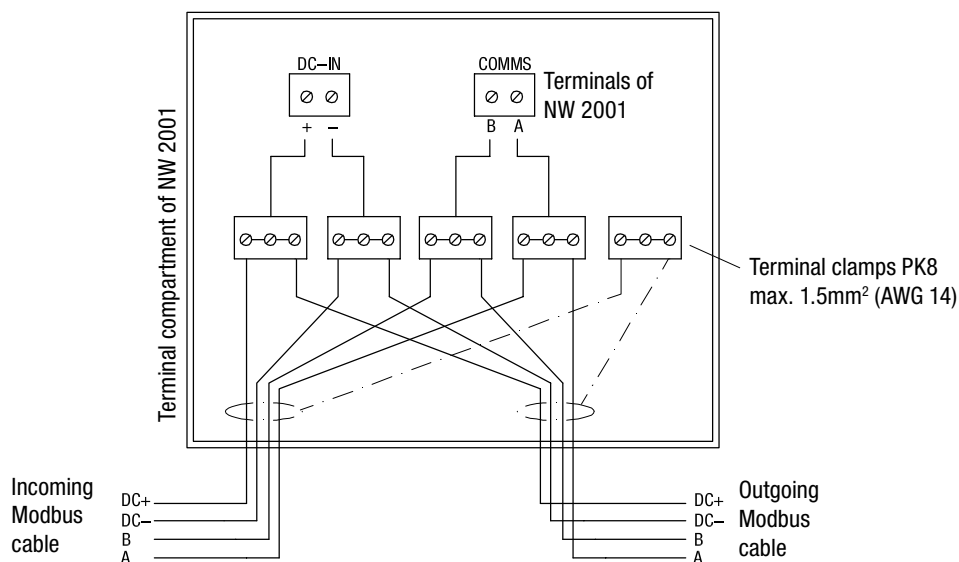

Electrical installation / Fieldbus Software

Profibus DP

Connection on NW 2001

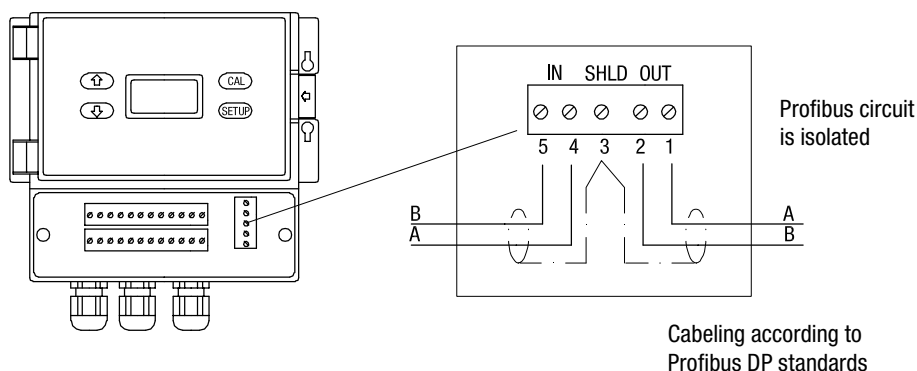

Fieldbus Software

HART

Supported commands

Universal commands:

Command (Dec):	Function:
0	Read Unique Identifier
1	Read Primary Variable
2	Read Current and Percent Range
3	Read Dynamic Variables and PV Current
6	Write Polling Address
11	Read Unique Identifier by Tag
12	Read Message
13	Read Tag, Descriptor and Date
14	Read PV sensor information
15	Read PV Output information
16	Read Final Assembly Number
17	Write Message
18	Write Tag, Descriptor and Date
19	Write Final Assembly Number

Common practice commands:

Command (Dec):	Function:
34	Write Primary Variable Damping value
35	Write Primary Variable Range values
44	Write Primary Variable Units
109	Burst Mode Control

HART Multidrop

The units will work in this way, if the current output at "4mA Adj" and "20mA Adj" (in the "Output adjustment menu") is set to nearly the same value (according to the system requirement). The command to go to fixed current mode is not supported.

Combination with other fieldbusses

Only one fieldbus can be used at the same time. The required bus can be chosen in the "Output Adjustment Menu" under "Comm Type".

Fieldbus Software

Modbus

Supported commands

Reading:
 Support of all diagnostics and parameters using command 03_{HEX}: Read Holding Register
 Main important registers to be used are:
 40124_{Dec} Low Level Setpoint in mm
 40125_{Dec} High Level Setpoint in mm
 40126_{Dec} Displayed Distance in mm
 Note: Depending on the used Modbus Master the "40" of the register address is not used.

Writing:
 Support of all parameters using command 06_{HEX}: Write Single Register
 Not supported is command 10_{HEX}: Write Multiple Register.

Multi-drop network

Factory setting of address is 1. Each unit which takes part of the network must be set to a individual address. This is done in the "Output Adjustment Menu" under "Comm Type".

Combination with other fieldbusses

Only one fieldbus can be used at the same time. The required bus can be chosen in the "Output Adjustment Menu" under "Comm Type".

Profibus DP

Data in GSD file

Reading of measured distance between Transducer face and material (in mm):

Byte:	Description:	Type:	Value:
1	Most significant Byte	Unsigned 16	Binary
2	Less significant Byte	Unsigned 16	Binary

Example:
 Byte 1 = 00000100 = 4_{Dec}
 Byte 2 = 00100011 = 35_{Dec}
 Value = 4 x 256 + 35 = 1059mm

Combination with other fieldbusses

Only one fieldbus can be used at the same time. The required bus can be chosen in the "Output Adjustment Menu" under "Comm Type".

Notes for use in Hazardous Locations

ATEX Zone classification

	category	usable in zone
Dust applications	1 D	20, 21, 22
	2 D	21, 22
	3 D *	22

*) in case of conductive dust additional demands for the installation are possible

General Notes

Marking

Devices with Ex approval are marked on name the plate

! Max. Surface Temperature

Rated max. surface temperature (valid for max. ambient and process temperature as stated in the technical data):

Nivowave units: 85°C (185°F)

Terminal boxes PK1 ATEX and PK2 ATEX: 80°C (176°F)

! Permitted zones for installation

