

Table of contents

	Page
Introduction	G2

Mode of operation	G2

Approvals	G2

Technical data	G3

Electrical connection	G4

Safety items	G5

Mounting	G5

Remarks for use in Hazardous Locations	G7

Subject to technical change and price change.

We assume no liability for typing errors.

All dimensions in mm (inches).

Different variations to those specified are possible.
Please contact our technical consultants.

All units of this information are CE - certified.

Introduction / Mode of operation

Introduction

- The ROTONIVO RN 4000 is a cost effective electromechanical level-limit-switch and is used for level monitoring of bulk goods. It is used wherever

- dustlike
- powdery
- granulated
- granular

media are handled.

Mainly it is used in easy applications with little mechanical loads

- Designed like a modular system, ROTONIVO level limit switches are used as

- Full detectors
- Demand detectors
- Empty detectors

in

- Silos
- Hoppers
- Storage containers
- Small containers
- Bunkers
- Weigher containers
- Discharge pipes

- ROTONIVO RN 4000 level limit switches are

- compact
- robust
- maintenance-free
- simple
- reliable
- insensitive to environmental influences

- ROTONIVO level limit switches have proved themselves in different industries such as:

- Chemical industry
- Wood industry
- Building industry
- Food processing industry
- Mechanical industry
- Plastics industry

Mode of operation

A low revolution synchronized gear motor drives a rotating measuring vane, which is for example mounted in a container (picture 1).

As soon as the material level, which is to be monitored, reaches the measuring vane, the vane is hindered in its rotation. The motor is freely suspended within the housing. The caused reaction torque is used to operate a micro switch giving a suitable electrical signal and to stop the motor (picture 2).

When the vane becomes free again due to the drop in material level, a spring draws the motor back into operating position, the micro switch returns to its initial position and the motor is switched on. The electrical output signal is then switched over (picture 1).

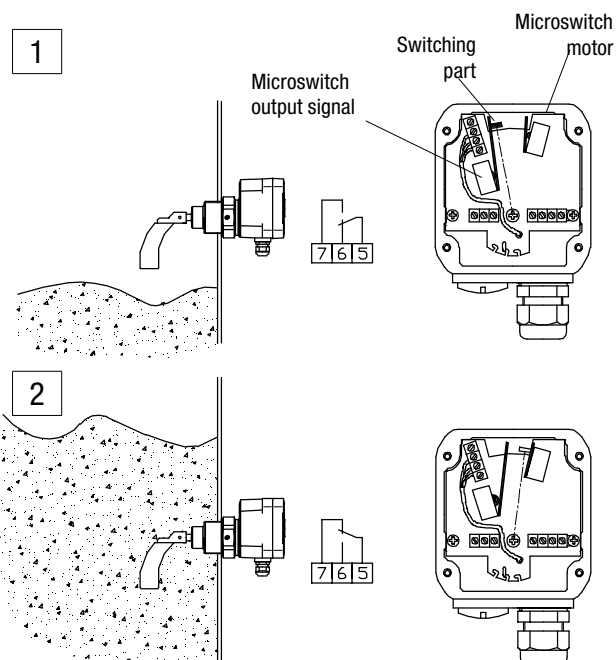

Approvals

For the ROTONIVO type RN 4001 approvals for Hazardous Locations category 1/3 D (zone 20/22) according directive 94/9/EG are available.

CE	EMC	EN 61326/A1
	Gen. purpose	EN 61010-1

Technical data

Dimensions

For detailed dimensions of the types RN 4001 see pricelist.

Mechanical data

Housing:	die-casted housing plastic PA6 with fibreglass; RAL 5012 blue
Enclosure:	IP 66 to EN 60529
Process connection:	thread according to selection; flanges on request
Material process connection:	plastic PA6 with fibreglas, black; version with approval ATEX 1/3 D (zone 20/22): aluminium
Material vane shaft:	stainless steel (1.4305/303)
Material measuring vane:	stainless steel (1.4301/304) or plastic PP, black
Tolerance length „L“:	± 10mm (pendulum shaft or rope extension)
Bearing:	slide bearing, high-grade
Sealing:	radial rotary shaft sealing DIN 3760 material : NBR (Acrylnitril-Butadien-rubber)
Friction clutch:	protection of the gear against impacts of the measuring vane
Pickup delay:	approx. 1,3sec
Sensitivity:	adjustable via the restoring force of the spring or geometry of measuring vane
Speed of measuring vane:	1 1/min

Electrical data

Supply voltage:	220..230V 50-60Hz (changeable to 110..120V) 110..120V 50-60Hz (changeable to 230..240V) 48V 50-60Hz (changeable to 24V) 24V 50-60Hz (changeable to 48V) 24V DC all voltages + 10% / -15%
-----------------	---

Multivoltage

230V 50Hz / 115V 50-60Hz / 24V DC
all voltages ± 15%

Installed load:	3VA (3W)
Connection terminal:	1x max. 1,5mm ²
Screwed cable gland:	1 x M20x1,5 (option 2x M20x1.5)
Signal output:	floating microswitch AC max. 250V, 2A, 500VA (cosφ = 1) DC max. 300V, 2A, 60W
Connection diagram:	inside of cover, datasheet
Protection class:	I

Operating conditions

Container over-pressure:	-0.5bar ... +0.8bar version with approval ATEX 1/3 D (zone 20/21): see page G7
Power density:	min. 100g/l
Feature of bulk material:	dustlike, powdery, granulated, granular
Maintenance:	not required
Temperature inside container:	-20°C upto +80°C
Ambient temperature of the housing:	-20°C upto +60°C

Max. surface temperature for use in Hazardous Locations (ATEX): see page G7

AC design

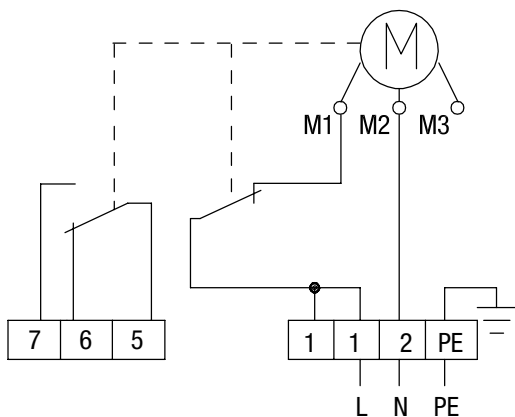

Multivoltage

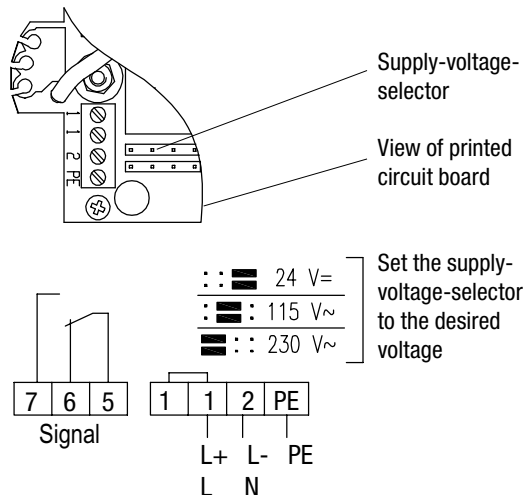

DC design

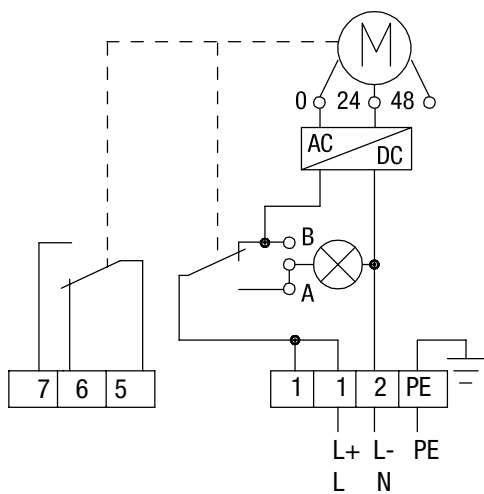

Switching logic

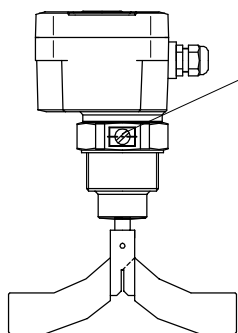
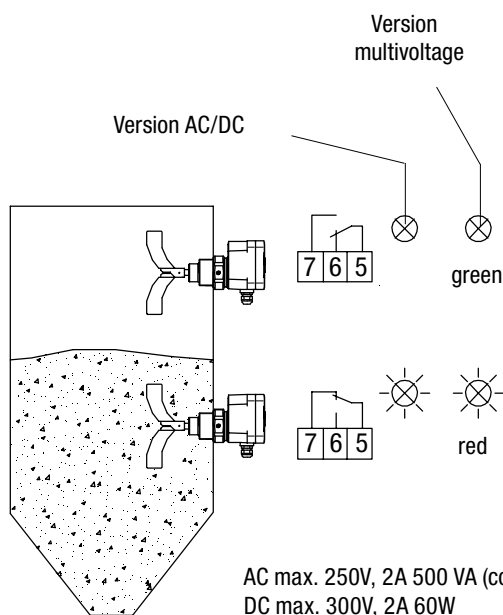

External equipotential bonding terminal

For ATEX 1/3 D zone 20/22): Connect with equipotential bonding of the plant.

Protection against static charging:

The PE terminal of the unit must be grounded to avoid static charging of the unit.

This is particularly important for applications with pneumatic conveying.

Safety items

- Installation, maintenance and commissioning must be carried out by qualified technical personnel.
- Compare the mains voltage applied with the specifications given on the label before switching the device on.
- For devices to use in Hazardous Locations ATEX1/3 D (zone 20/22) the requirements of the EN 50281-1-2 (e. g. regarding dust deposits and temperatures) must be observed.
- For terminal connection of the device, the local regulations or VDE 0100 (regulations of German electrotechnical engineers) must be observed.
- Switch off the supply voltage before opening the housing.
Dangerous voltage!
- In the case of incorrect handling or handling malpractice, the electric safety of the device cannot be guaranteed.
- Operate only with closed lid of the housing.
- For devices to use in Hazardous Locations ATEX 1/3D (zone 20/22) the respectively valid installation regulations must be observed.
- Use a fuse for the supply voltage (max. 4A).
- Isolating signal output - mains voltage: 3kV~
- A voltage disconnecting switch must be provided near the switch. A RCCB protection switch is necessary.
- Provide protection for relay contacts to protect the device against spikes, if inductive loads are connected.

Mounting

The unit must be mounted with the thread or the flange on the container. Mounting may be vertical, oblique or horizontal. For the individual mounting of the several ROTONIVO-models see pricelist.

The electrical connections are made in accordance with the connection diagram. Make sure, that the cable in the screwed cable gland is seated tightly without fail. For models according to ATEX 1/3D a pull relief must be provided for the connection cables.

After mounting, turn the housing in the right direction. The screwed cable gland must show downwards (see drawing right hand). This makes sure, that the unit works fine and protects, that water enters into the housing through the screwed cable gland.

When the unit is used outside, we recommend to use the weather-protection-cover. It protects the unit against moisture, heat, cold and prevents the formation of condensation water in the interior of the housing.

Adjusting the unit onsite is not required.

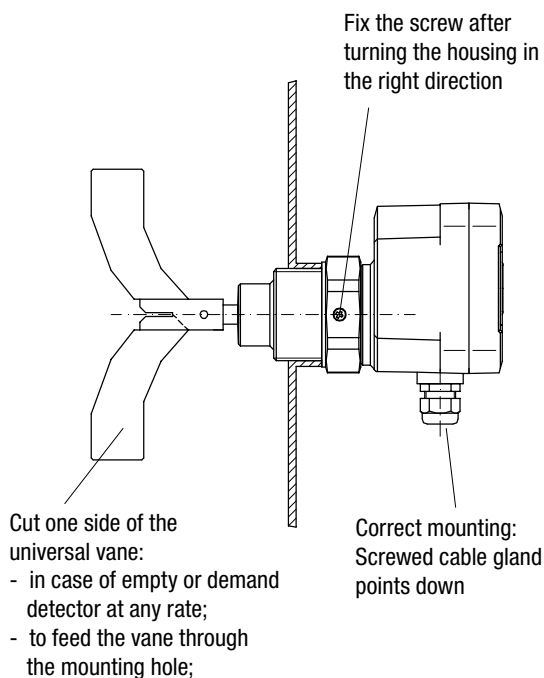

Adjustment of the spring

The spring is adjustable in 3 positions. It should be changed only if necessary.

„Fine“: for light material;
 „Medium“: suitable for nearly every material;
 „Coarse“: for very sticky material;
 Factory setting is „medium“.

The spring can be changed via small pliers.

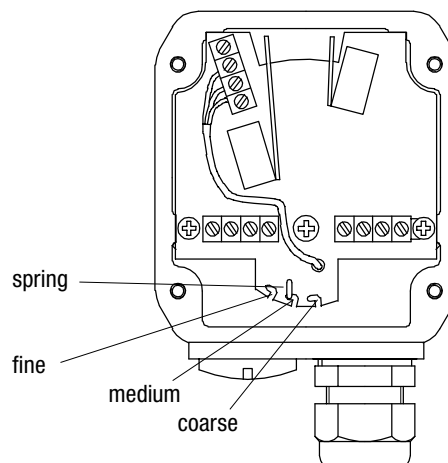

Mounting

Shaft extensions

There are two different shaft extensions available:
 Either upto 1m with the kit „Pendulum shaft“ or more robust upto 2m with the kit „Rope extension“.

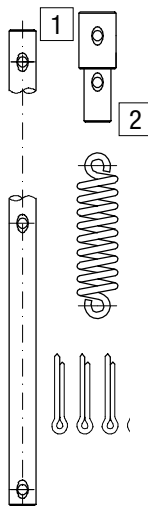

Kit „Pendulum shaft“

The kit „Pendulum shaft“ consists of an extension shaft (1) to be mounted with a spring (2) on the shaft of the RN 4001. Each 100mm there are drilled holes in the shaft for mounting the measuring vane. This enables to mount the vane at different extension length "L". In case of high material density it is recommended to cut the shaft below the vane.

The kit „Pendulum shaft“ is available for max. L=0.5m or max. L=1.0m.

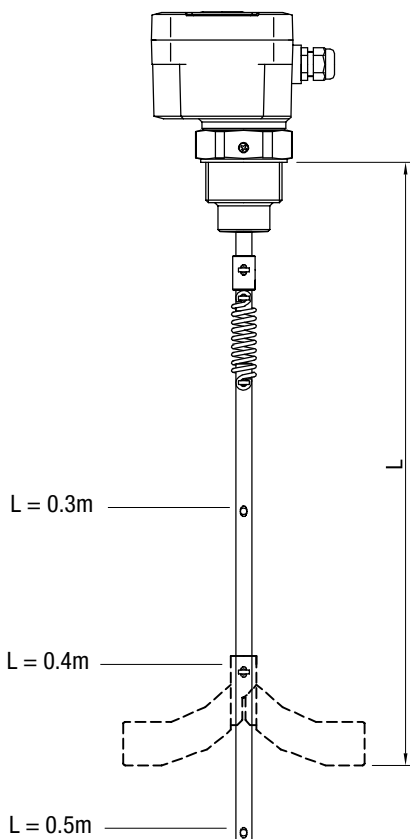

Example:
 RN 4001 with pendulum shaft
 L = 0.5m;
 measuring vane mounted at
 L = 0.4m

Kit „Rope extension“

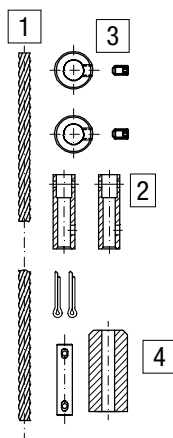

With the kit „Rope extension“ the shaft of the RN 4001 is extended by a 8mm stainless steel rope (1). The rope is mounted with the shaft and the measuring vane by each a bush (2) and a clamp ring (3). The rope weight (4) is put over the rope to tight it.

The kit is available for L=2m. Other extension lengths are possible by cutting the rop to the required length.

RN 4001 with rope extension

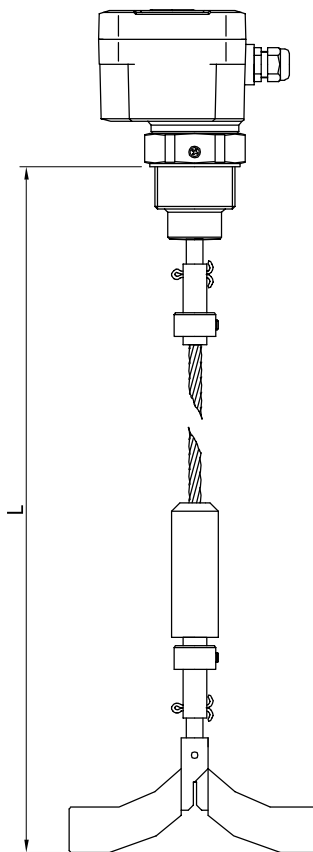

Length of rope:

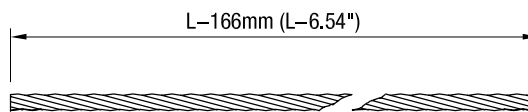

Remarks: ATEX

Remarks for use in Hazardous Locations according to ATEX

Zone classification

The approval according to ATEX (directive 94/9/EC) for Hazardous Areas category 1/3 D (zone 20/22) determines the following classification:

Device category to 94/9/EG	usable in zone
1 D	20, 21, 22
3 D*)	22

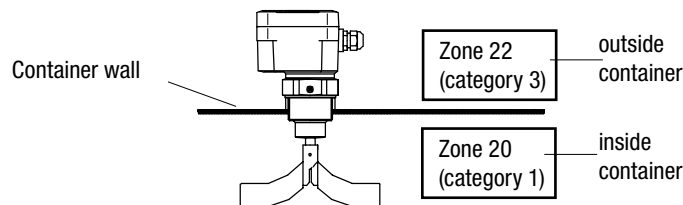

*) in case of conductive dust, additional requirements for the installation are necessary.

General Notes

Marking

Devices with EX approval are marked on the name plate.



Process pressure for ATEX



The device construction allows process over-pressure upto 0.8 bars (11.6psi) (see name plate). These pressures are allowed for test purposes. The definition of the ATEX is only valid for a container overpressure between -0.2..+0.1 bar (-2.9..+1.45psi). For higher or lower pressures the approval is not valid.

Process and ambient temperature

The permitted temperature ranges are marked on the name plate.

Maximum operating temperature

The following information shows the maximum surface temperature at the warmest part of the unit which can occur in failure case (according to ATEX definition).

maximum Surface temperature in °C	Ambient temperature in zone 22 in °C	Medium temperature in zone 20 in °C
95	60	80
85	50	70
75	40	60

