

## Table of contents

---

	Page
Dimensions	P2
Selection / Option	P3
-----	
Spare parts	P4
-----	
Electrical installation	P5

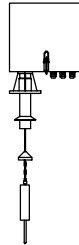

Subject to technical change.

All dimensions in mm (inches).

We assume no liability for typing errors.

Valid from 01.04.2010 until 31.03.2011 unless otherwise agreed.

By publishing this option list all other option lists become invalid.

Different variations to those specified are possible. Please contact our technical consultants.

## Dimensions

### Electromechanical measuring system for bulk goods

Protection class IP54, low maintenance, easy to service.

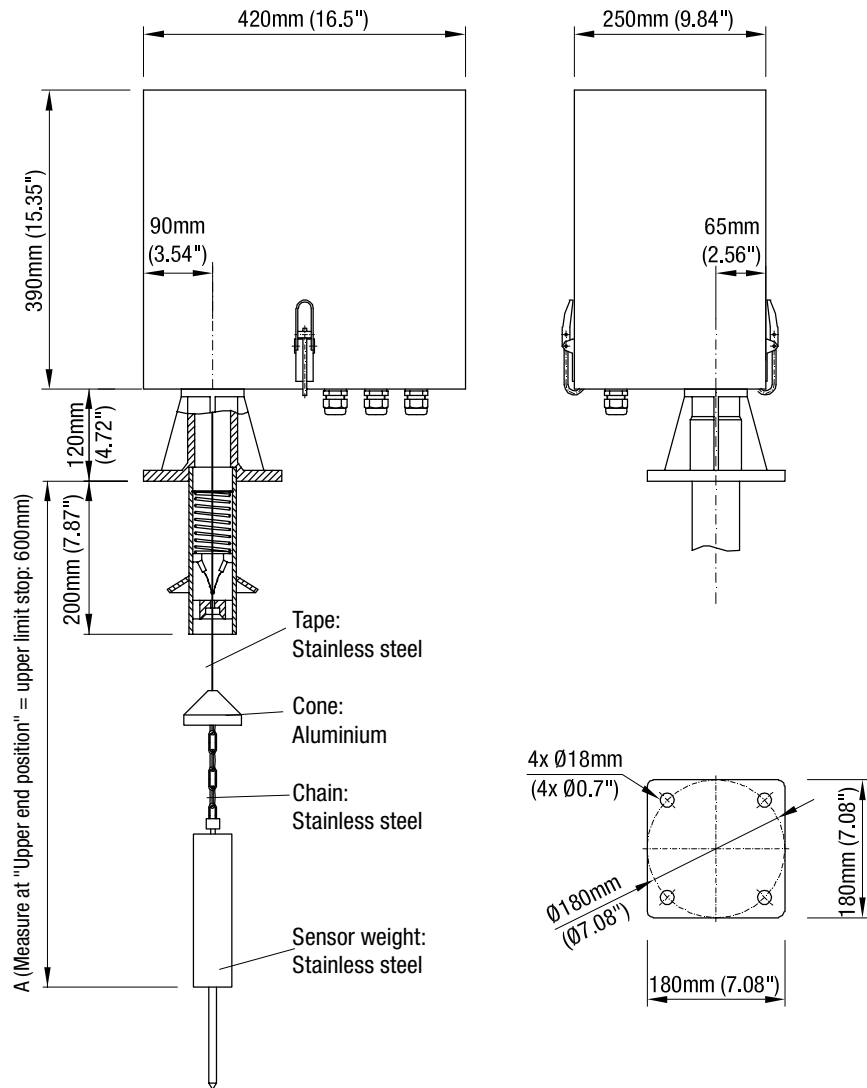

pos. 21  
**Mounting set Ø18**

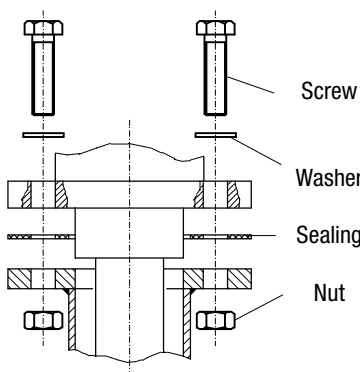

pos. 22  
**Mounting set M16**

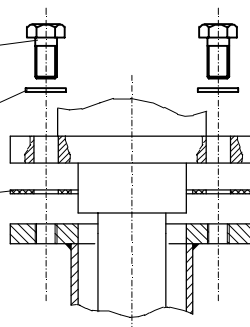

pos. 23  
**Weather protection cover**  
 (Aluminium)

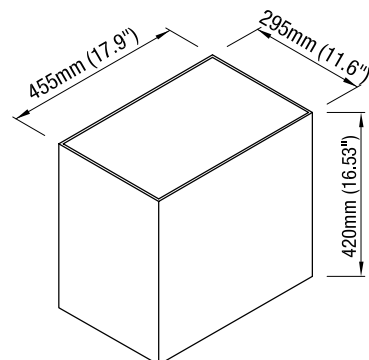

## Selection / Options

### Selection

### Basic type SLB 300

- pos. 2     **Power supply**  
           2 3x400V + N, 50–60 Hz <sup>(1)</sup> .....
- pos. 3     **Evaluation**  
           B current signal 0/4–20mA analogue (volume specific) and  
           digital counting pulse output (volume specific) .....
- pos. 4     **Sensor weight**  
           1 stainless steel (standard) .....
- 2 folding cover / canvas .....
- (others on request)
- pos. 5     **Measuring range**  
           A max. 30m .....
- B max. 50m .....
- C max. 70m .....
- pos. 6     **Software language**  
           D German .....
- E English .....
- F French .....

Position	1	2	3	4	5	6	
	SLB	B	B				← Order code

All positions are available in special design (use code "Z").

<sup>(1)</sup> other voltages on request

### Options

- pos. 21    **Mounting set ø18 (for opposite flange with hole ø18)** .....
- 4 pieces screw M16x60 A2
- 4 pieces nut M16 A2
- 4 pieces washer A2
- 1 piece sealing, max. 125°C
- pos. 22    **Mounting set M16 (for opposite flange with thread M16)** .....
- 4 pieces screw M16x30 A2
- 4 pieces washer A2
- 1 piece sealing, max. 125°C
- pos. 23    **Weather protection cover** .....

Version with other pulse output or other pressure and temperature features on request.

## Spare parts

### Spare parts

<b>Loose tape</b>	mf-va-012 x 0.2	loose tape (price per 1m) .....
<b>Tape roller complete</b>	sb110040 + mf-va-012 x 0.2 (30m)	tape roller with 30m tape .....
	sb110040 + mf-va-012 x 0.2 (50m)	tape roller with 50m tape .....
	sb110040 + mf-va-012 x 0.2 (70m)	tape roller with 70m tape .....
<b>Sensor weight</b> (delivery parts: see figure below)	sb100600	stainles steel 1.4301 .....
	sb100620	folding cover 1.4301 / canvas .....

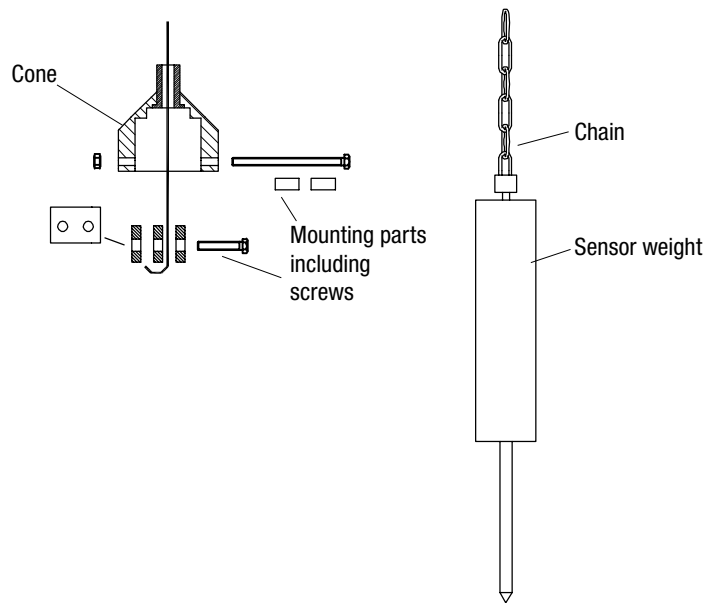

## Electrical connection

