

Table of contents

	Page
Safety notes / Technical support	G2

Introduction	G3

Technical data	G4

Approvals	G11

Options	G12

Mounting	G13

Electrical installation	G16

Signal output / Diagnose	G21

Sensitivity / Maintenance	G26

Notes for use in Hazardous Locations	G27

Assembly VN ..040	G31

Assembly VN ..020 with separate housing	G36

Subject to technical change and price change.

We assume no liability for typing errors.

All dimensions in mm (inches).

Different variations to those specified are possible.
Please contact our technical consultants.

Safety notes / Technical support

Notes

- Installation, maintenance and commissioning must be carried out only by qualified technical personnel.
- The product must be used only in the manner outlined in this instruction manual.

Special attention must be paid to warnings and notes as follows:



WARNING

Relates to a caution symbol on the product and means, that a failure to observe the necessary precautions can result in death, serious injury and/or considerable material damage.



WARNING



Relates to a caution symbol on the product and means, that a failure to observe the necessary precautions can result in death, serious injury and/or considerable material damage.

This symbol is used, when there is no corresponding caution symbol on the product.

CAUTION

A failure to observe the necessary precautions can result in considerable material damage.

Safety symbols

In manual and on product	Description
	CAUTION: refer to accompanying documents (manual) for details.
	Earth (ground) Terminal
	Protective Conductor Terminal

Technical support

Please contact your local supplier (see www.uwt.de for address). Otherwise you can contact:

UWT GmbH
Westendstr. 5
87488 Betzigau
Germany

Tel. 0049 (0)831 57123-0
Fax. 0049 (0)831 76879
info@uwt.de
www.uwt.de

Introduction

Applications

The device is used for level monitoring in all types of containers and silos.

It can be used with all powdery and granulated bulk materials that do not show a strong propensity to form crusts or deposits. Detection of solids in water is also possible.

The units can be delivered with a wide range of Ex-approvals for use in Gas and Dust Hazardous Areas.

A selection of fields of application:



- **Building materials industry**
lime, styrofoam, moulding sand, etc.
- **Food industry**
milk powder, flour, salt, etc.
- **Plastics industry**
plastics granules etc.
- **Timber industry**
- **Chemical industry**
- **Mechanical engineering**

The VIBRANIVO oscillating probe is normally screwed into the lateral container wall so that it is level with the filling height to be registered and monitored.

The device can also be mounted from the top of the container. In this case an extension piece is used to mount the probe level with the height to be registered.

The length of the probe can be up to 4m (157") with an extension tube (VN ..030) or up to 20m (787") with an extension rope (VN 2050/ 6050).

The use of a sliding sleeve is recommended so that the switch point can be changed easily during operation of the device.

Function

The piezo-electrically stimulated oscillating fork vibrates at its mechanical resonance frequency. If the probe is covered by the bulk material, the damping thus generated is registered electronically and a corresponding signal output is actuated. The oscillation of the fork ensures a certain self-cleaning.

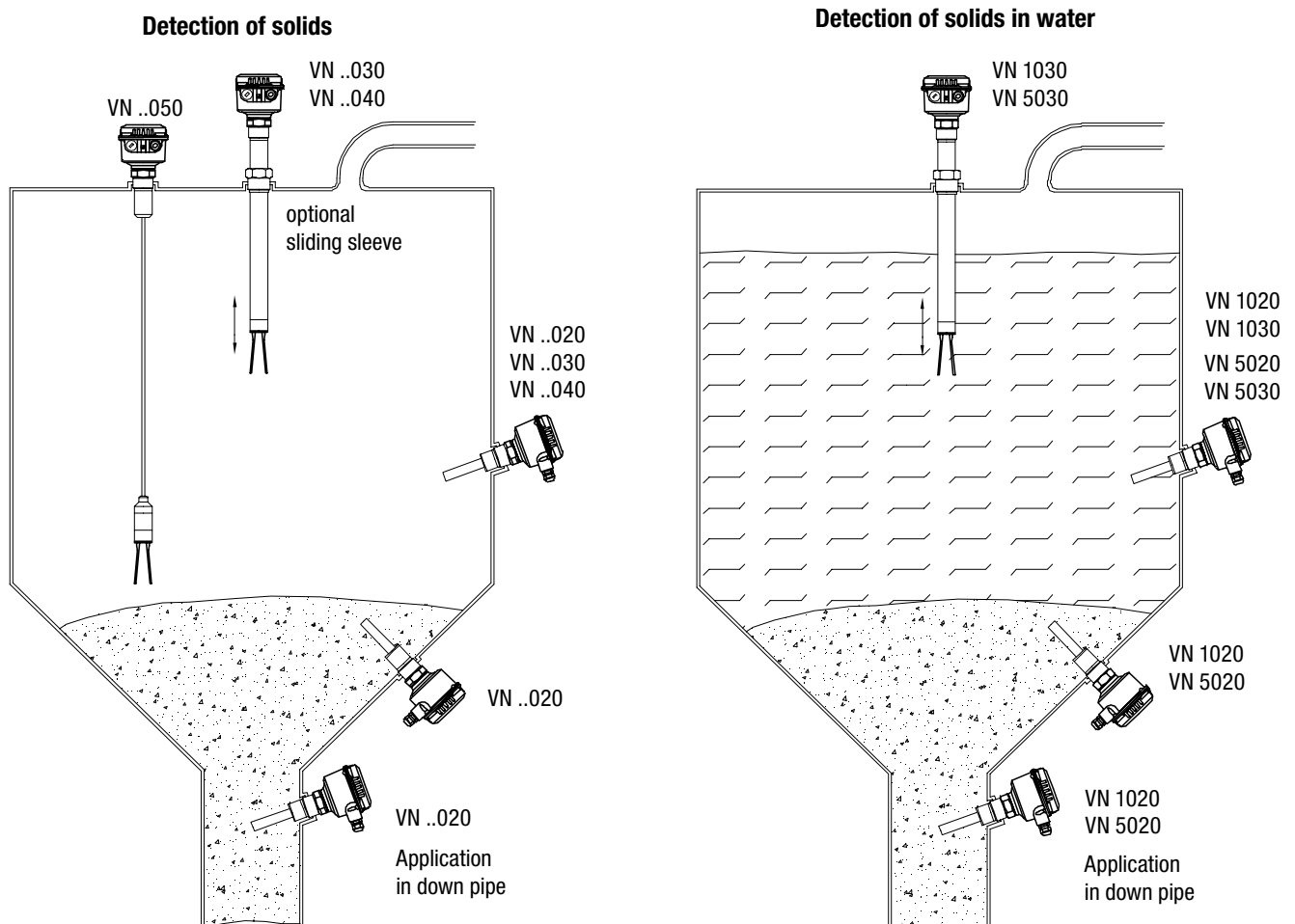

Technical data

Housing versions

Series VN 1000 / 2000

Standard

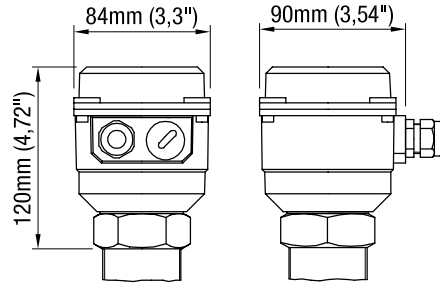

Series VN 5000 / 6000

Standard

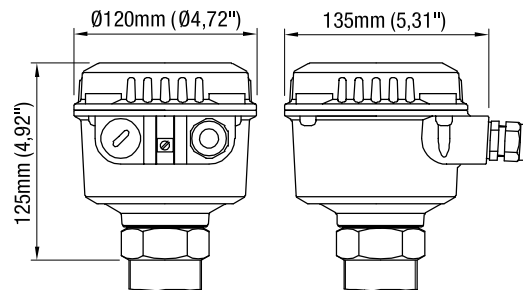

de

Explosionproof with
 increased safety
 terminal box

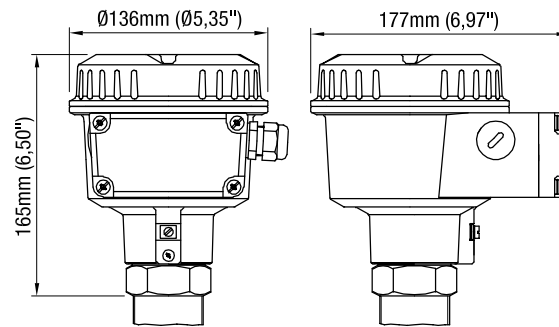

d

Flameproof /
 explosionproof

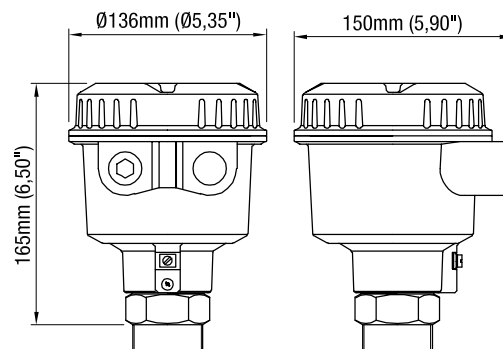

Technical Data

Extensions

VN ..020

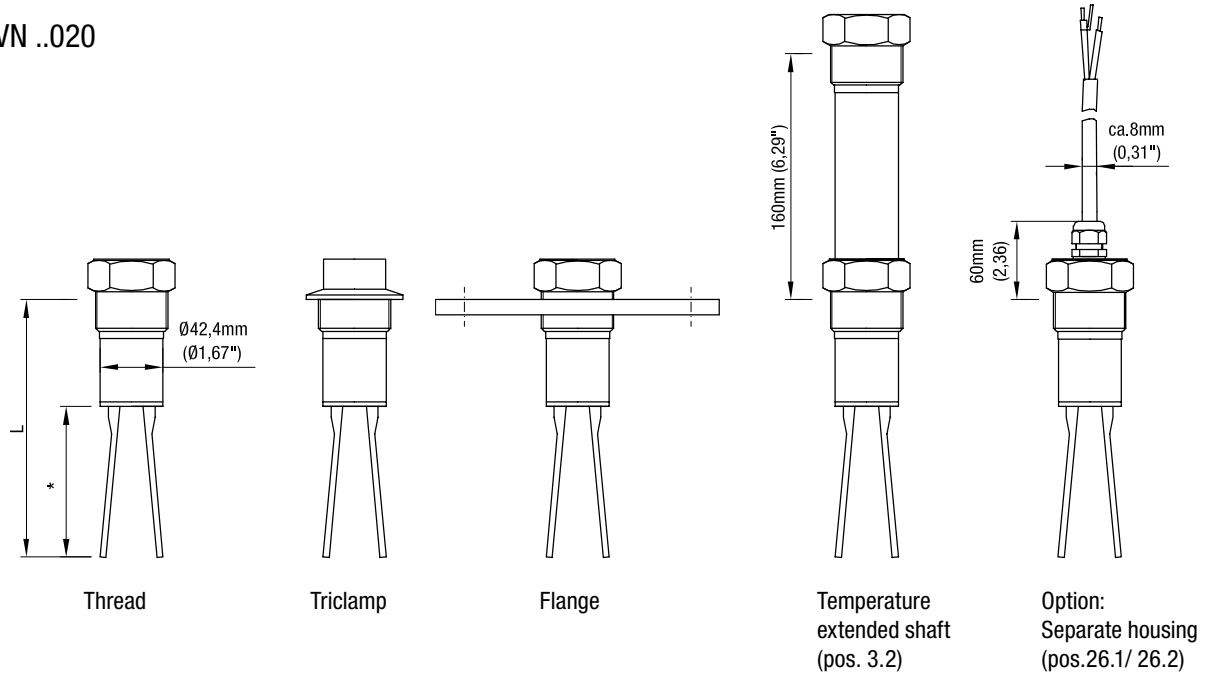

	L	
	without option	with option: enhanced sensitivity (pos. 26x) Vibrasil 70 (pos. 26a) Vibrasil 90 (pos. 26b)
VN 1020 VN 5020	165mm (6.5")	
VN 2020 VN 6020	235mm (9.25")	260mm (9.84")

* see page 6 bottom right

VN ..030

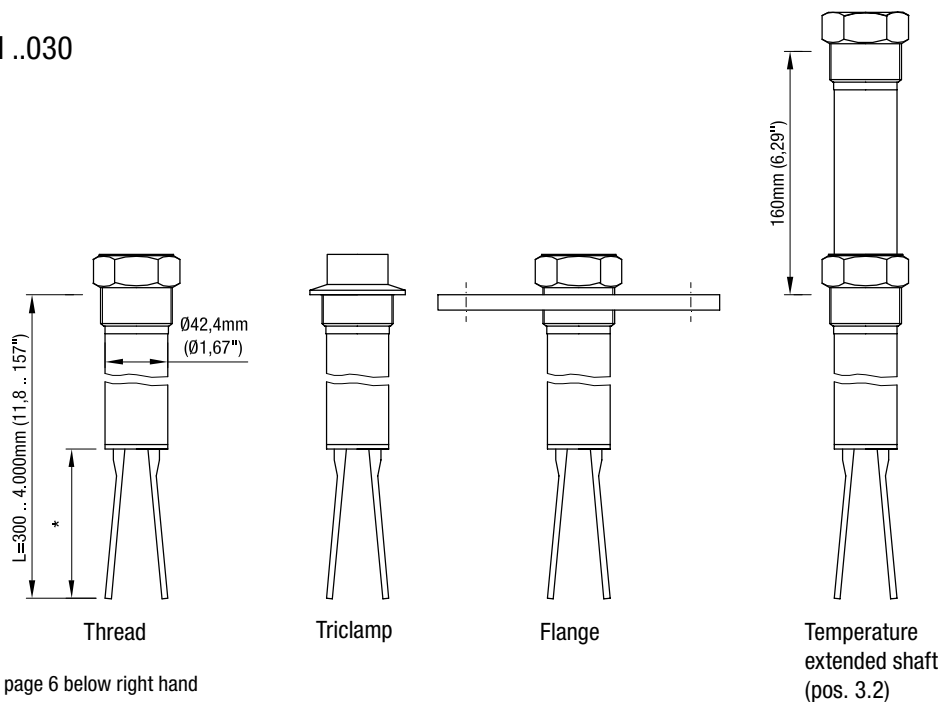

* see page 6 below right hand

Technical data

VN ..040

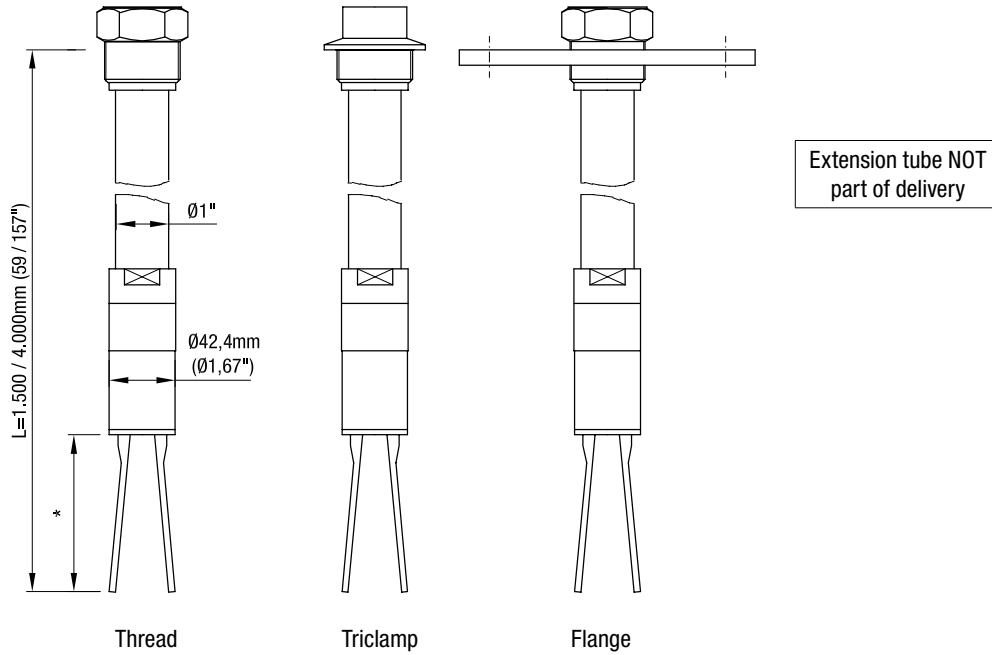

* see bottom right

VN ..050

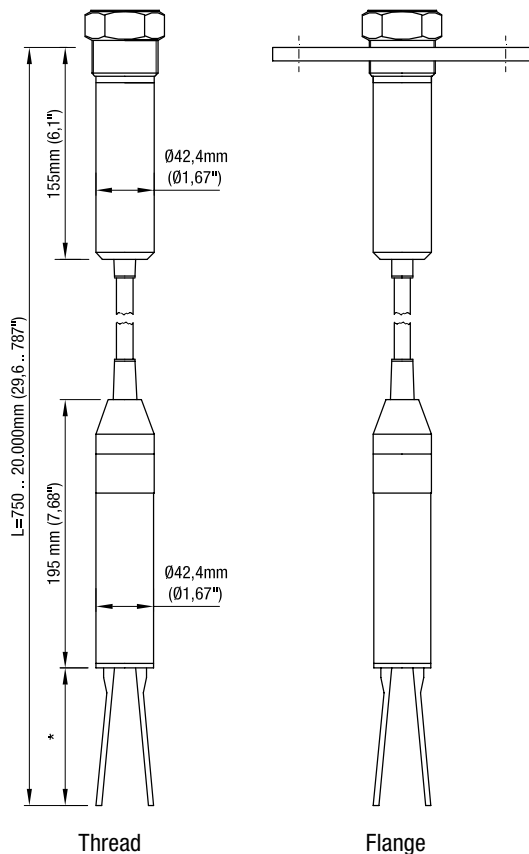

* see right

* Length of oscillating rods

VN 10..0
 VN 50..0

VN 20..0
 VN 60..0

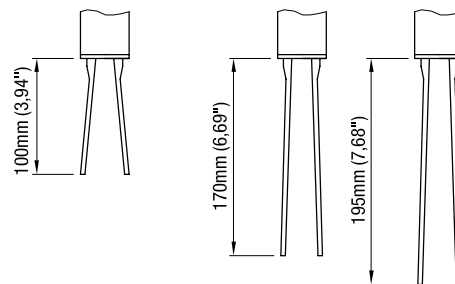

with option
 Enhanced sensitivity (pos.26x)
 Vibrasil® 70 (pos.26a)
 Vibrasil® 90 (pos.26b)

Technical data

Electrical data

Connection terminals	max. 4mm ² (AWG 12)
Cable entry	M20 x 1.5 screwed cable gland NPT 1/2" conduit connection NPT 3/4" conduit connection (only VN 5000 / 6000)
Signal delay	Sensor free -> covered ca. 1 sec Sensor covered -> free ca. 1..2 sec On the electronic module "Universal voltage Relay DPDT" is an electronic delay, adjustable upto 30sec.
Safety operation (FSL,FSH)	Switchable for minimum or maximum safety
Sensitivity	Adjustable in 2 levels (A/B)
Vibration frequency	VN 1000 / 5000: ca. 350Hz VN 2000 / 6000: ca. 125Hz ca. 90Hz (enhanced sensitivity)
Installation category	III
Pollution degree	2

Electronic modules	Universal voltage Relay SPDT (VN 1000/ 2000/ 5000/ 6000)	Universal voltage Relay DPDT (VN 1000/ 2000/ 5000/ 6000)	3-wire PNP (VN 1000/ 2000/ 5000/ 6000)
Power supply	19..230V AC 50-60Hz 19..55V DC +10%	19..230V AC 50-60Hz 19..55V (36V*)DC +10% * Version with intrinsic safe connection between Electronic module and Vibrating fork (see pos.4 in pricelist)	18V..50V DC +10%
Max. ripple of power supply	7 V _{ss} at DC	7 V _{ss} at DC	7 V _{ss}
Installed load	max. 8VA / 1,5W	max. 18VA / 2W	max. 1,5W
Signal output	Floating relay SPDT VN 1000 / 2000: AC max. 253V, 4A, 500VA at cos Phi = 1 DC max. 253V, 4A, 60W VN 5000 / 6000: AC max. 250V, 8A non inductive DC max. 30V, 5A non inductive	Floating relay DPDT VN 1000 / 2000: AC max. 253V, 4A, 500VA at cos Phi = 1 DC max. 253V, 4A, 60W VN 5000 / 6000: AC max. 250V, 8A non inductive DC max. 30V, 5A non inductive	Open Collector: permanent load max. 0.4A short-circuit and overload protected turn-on voltage: max. 50V (reverse protection)
Intrinsic safe ratings	-	-	-
Indicating light	Status of signal output by built-in LED	Status of signal output by built-in LED	Status of signal output by built-in LED
Isolation	Power supply to signal output: 2225 Vrms	Power supply to signal output: 2225 Vrms Signal output to signal output (DPDT): 2225 Vrms	-
Protection class	I	I	III

Technical data

Electronic modules	2-wire without contact (VN 1000/2000/ 5000/6000)	NAMUR IEC 60947-5-6 (VN 2000/ 6000)	8/16mA or 4-20mA (VN 1000/2000/ 5000/6000)	8/16mA (VN 5000/ 6000)
Power supply	19..230V 50/60Hz / DC +10%	ca. 7 ..9 V DC (spec. IEC 60947-5-6)	Non intrinsic safe version: 12.5 .. 36V DC +0% Intrinsic safe version: 12.5 .. 30V DC +0%	12.5 .. 36V DC +0%
Max. ripple of power supply	7 V _{ss} at DC	-	-	-
Installed load	max. 1.5VA / 1W	max. 30mA (for non intrinsic safe application)	max. 0.8W	max. 0.8W
Signal output	<p>Load current: min. 10mA max. 500mA permanent max. 2A < 200ms max. 5A < 50ms Voltage drop on the electronic module: max 7V with closed electric circuit.</p> <p>Cutoff current with open electric circuit: max 5mA.</p> <p>To enable a safe opening of relay contacts, the cutoff current will be set for some milliseconds to 0, when opening the electric circuit.</p> <p>Short-circuit- and overload-protected.</p>	<1mA or > 2,2mA (spec. IEC 60947-5-6)	<p>Setting 8/16mA: 8mA or 16mA +- 0.5mA.</p> <p>Setting 4-20mA: Output current depends on the vibration amplitude of the fork between 6mA for damped vibration and 20mA for full vibration. Resolution is 0.1mA.</p>	8mA or 16mA +- 1mA
Intrinsic safe ratings	-	<p>U_i 20V I_i 67mA P_i 0.17W C_i negligible small L_i negligible small</p>	<p>Intrinsic safe version: U_i 30V I_i 130mA P_i 0.8W C_i negligible small L_i negligible small</p>	-
Indicating light	Status of signal output by built-in LED	Status of signal output and diagnose of vibration by built-in LED	Status of signal output and diagnose of vibration by built-in LED	Status of signal output by built-in LED
Protection class	I	III	III	III

Technical data

Mechanical data

Housing Aluminium housing, powder coated RAL 5010 gentian blue

Degree of protection VN 1000/ 2000: IP 66 (EN 60529)
 VN 5000/ 6000 NEMA 4X, Type 4X, IP 66 (EN 60529)

Process connection Material: stainless steel 1.4301 (304) or 1.4571 (316TI)
 Thread: R 1½" tapered DIN 2999 or NPT 1½" tapered ANSI B 1.20.1
 Triclamp
 Flanges according to selection

Oscillator Material: stainless steel 1.4301 (304) and 1.4581; optional 1.4571 (316TI) and 1.4581
 Surface treatment of vibrating rods: polished, Ra ≤ 0,5µm; teflon (on request)

Overall weight (ca.)

VN 1000/ 2000	Standard housing	Extension
VN 1020/ 2020:	1.6kg (3.5 lbs)	-
VN 1030/ 2030:	1.6kg (3.5 lbs)	+2.5kg/m (+5.5 lbs per 39.3")
VN 1040/ 2040:	2.0kg (4.4 lbs)	delivery without extension tube
VN 1050/ 2050:	4.0kg (8.8 lbs)	+0.5kg/m (+1.1 lbs per 39.3")

VN 5000/ 6000	Standard housing	de-housing	d-housing	Extension
VN 5020/ 6020:	2.1kg (4.6 lbs)	3.2kg (7 lbs)	2.8kg (6.2 lbs)	-
VN 5030/ 6030:	2.1kg (4.6 lbs)	3.2kg (7 lbs)	2.8kg (6.2 lbs)	+2.5kg/m (+5.5 lbs per 39.3")
VN 5040/ 6040:	2.5kg (5.5 lbs)	3.6kg (7.9 lbs)	3.2kg (7 lbs)	delivery without extension tube
VN 5050/ 6050:	4.5kg (9.9 lbs)	5.6kg (12.3 lbs)	5.2kg (11.4 lbs)	+0.5kg/m (+1.1 lbs per 39.3")

Technical data

Operating conditions

Ambient temp. (housing)	-40°C.. +60°C (-40 .. +140°F) -25°C.. +60°C (-13 .. +140°F)	VN ..020/ VN ..030 and VN ..040 VN ..050
Process temperature	-40°C.. +150°C (-40 .. +302°F) -40°C.. +110°C (-40 .. +230°F) -25°C.. +80°C (-13 .. +176°F)	VN ..020/ VN ..030 and VN ..040 Mounting for process temperature up to 150°C (302°F): see drawing VN ..020 with Ex approval and separate housing (pricelist option 26.1, 26.2) VN ..050

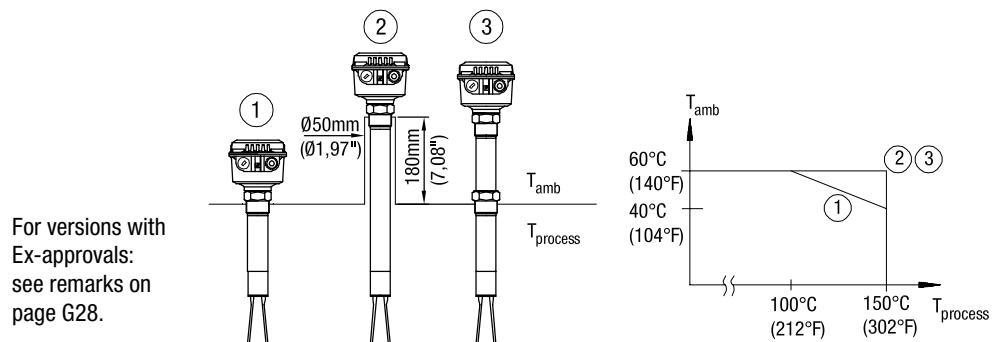

	Setting B	Setting A	
VN 1000/ 5000:	ca. 50 g/l (3lb/ft ³)	ca. 150 g/l (9lb/ft ³)	
VN 2000/ 6000:	ca. 20 g/l (1.2lb/ft ³) ca. 5 g/l (0.3lb/ft ³)	ca. 75 g/l (4.5lb/ft ³) ca. 20 g/l (1.2lb/ft ³)	Standard version Enhanced sensitivity

Features of bulk material	No strong caking tendencies Max. grain size 10mm (0.39")		
Max. mechanical load	600N laterally (on oscillator rods) Recommended protection in case of high material loading: mounting of a protective canopy above the probe		
Max. mechanical torque	300 Nm 100 Nm	VN ..030 VN ..040	
Max. tractive force	2kN	VN ..050	
Max. process pressure	10bar (145psi) 10bar (145psi)	VN ..020, VN ..030 VN ..040 (depending on the quality of the local mounted sealing of the extension tube)	
	6bar (87psi)	VN ..050	
	For versions with Ex-approvals: see remarks on page G27.		
Relative Humidity	0-100%, suitable for outdoor use		
Altitude	max. 2.000m (6.562ft)		

Approvals

	VN 1000	VN 2000	VN 5000	VN 6000				
General Purpose * (Ordinary Locations)	•	•	•	•	CE FM CSA	EN 61010-1 (IEC/CB)		
Hazardous Locations *	•	•	•	•	ATEX	Dust explosion	ATEX II 1D and 1/2 D	
	•	•	•	•		Gas explosion	Intrinsic safe Flameproof	ATEX II 1G and 1/2G EEx ia IIC ATEX II 2G EEx d IIC
			•	•		Flameproof / increased safety	ATEX II 2G EEx de IIC	
			•	•	FM	Dust explosion	Cl. II, III Div. 1 Gr. E,F,G	
			•	•		Gas explosion	Intrinsic safe	IS Cl. I Div. 1 Gr. A-D Cl. I Zone 0 and 0/1 AEx ia IIC
			•	•		Gas explosion	Flameproof	XP-IS Cl. I Div. 1 Gr. B-D Cl. I Zone 1 AEx d [ia] IIC
			•	•		Gas explosion	Flameproof / increased safety	Cl. I Zone 1 AEx de [ia] IIC
			•	•	CSA	Dust explosion	Cl. II, III Div. 1 Gr. E,F,G Ex DIP A20 and A20/21	
			•	•		Gas explosion	Intrinsic safe	IS Cl. I Div. 1 Gr. A-D Cl. I Zone 0 and Zone 0/1 Ex ia IIC
			•	•		Gas explosion	Flameproof	XP-IS Cl. I Div. 1 Gr. B-D Cl. I Zone 1 Ex d [ia] IIC
		•	•		Gas explosion	Flameproof / increased safety	Cl. I Zone 1 Ex de [ia] IIC	
					Detailed allocation of types and electronic modules to approvals: see pricelist.			
EMC	•	•	•	•		EN 61326 -A1		

Pressure Equipment Directive (97/23/EC)

The units are not subject to this directive, because they are classified as „pressure-keeping equipment“ and do not have a pressurized housing (see Art.1, Abs. 2.1.4).
 The units are designed and manufactured in accordance to the Pressure Equipment Directive.



The unit is NOT intended for use as a “equipment part with safety function (Art.1, Abs. 2.1.3).
 If the units should be used as „equipment part with safety function, please contact the manufacturer.

* depending on selected version in pricelist.

Options

Weather-protection-cover

When the measuring device is used outdoor, the use of the weather-protection-cover is recommended. It protects the device from all atmospheric influences such as:

- rain water
- condensation of water
- excessively high temperatures due to insolation
- excessively low temperatures in winter

Material: PE, weather and temperature stable

Not available for housing version d and de.



For use in Hazardous Locations: only permitted for Category 3 (zone 2 and 22) or Division 2.

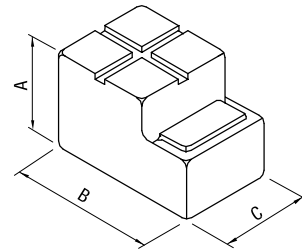

	VN 10..0 VN 20..0	VN 50..0 VN 60..0
A	100mm (3.94")	130mm (5.12")
B	165mm (6.5")	200mm (7.87")
C	88mm (3.46")	125mm (4.92")

Sliding sleeve

VN ..030 G2" ISO 228 or
 2" NPT ANSI B 1.20.1
 Material: 1.4301 (304) or 1.471 (316Ti)
 Sealing material to the extension tube: viton

VN ..040 Because the outer diameters of the locally mounted 1" tube may differ, sliding sleeve on request.
 Not for Hazardous Locations.

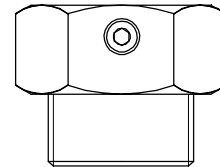

Mounting set

Screws and washers for fixing the unit on a flange.

Glass window in lid

To see the indicating light on the electronic module from outside.

Not available for housing version d and de.

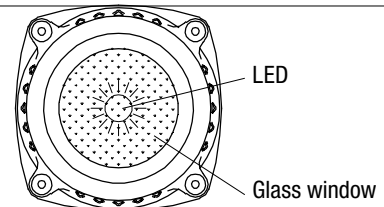

Bulb in cable gland

Bright indicating light seen from outside.

Not available for use in Hazardous Locations.

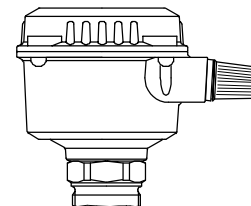

Plug 4-pole (incl. PE)

Used instead of cable gland.

Not available for use in Hazardous Locations and FM / CSA general Purpose.

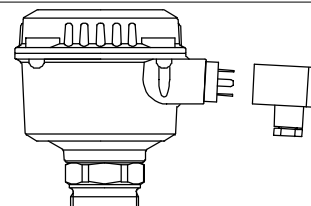

Mounting

General Safety Instructions

Detection of solids in water

CAUTION:

Detection of solids in water only permitted with types VN 1020/ 1030/ 5020/ 5030.
 Other types on request.

Process pressure



Improper installation may result in loss of process pressure.

Chemical resistance against the medium



Materials of construction are chosen based on their chemical compatibility (or inertness) for general purposes. For exposure to specific environments, check with chemical compatibility charts before installing.

VN ..050:

Consider the chemical compatibility of the extension cable (material PUR) and the rubber seals on both ends of the extension cable (material neoprene).

Mechanical load



The torque at the fastening spot must not exceed
 300Nm (VN ..030) or
 100Nm (VN ..040)

Maximum length „L“ in relation
 to the deviation (in degrees) from vertical installation:

Max. deviation	Max. length „L“
5°	4000 mm (157.5“)
45°	1200 mm (47.24“)
>45°	600 mm (23.62“)

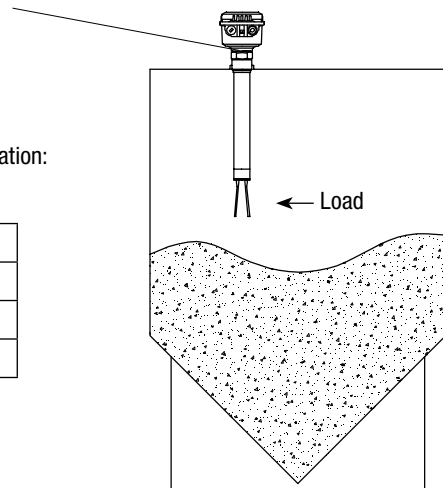

Mounting location

Comply with distance from incoming material and from the silo wall.

The installation has to be done in a way, that the sensor elements cannot hit the wall of the silo. The flow of the medium and fixtures in the container must be considered. This is especially important for extension lengths of more than 3m (118.1“).

2“ sliding sleeve

Tighten both locking screws M8 with 20 Nm
 to obtain resistance against pressure.

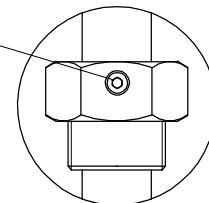

Flange mounting

A plastic sealing must be used to tighten the flange.

Fastening of the 1½” process connection

Mounting torque for the 1½” thread may not exceed 80Nm.
 Use a 50mm (1.97”) open-end wrench (do not turn the housing).

Mounting

! Additional Safety Instructions for Hazardous Locations

Installation regulations	For the use of devices in Hazardous Locations the respectively valid installation regulations must be observed. ATEX: The requirements of the EN 50281-1-2 (e.g. regarding dust deposits and temperatures) must be observed.
Sparks	The installation has to be carried out in a way, that mechanical friction or impact does not cause sparks between the aluminium enclosure and steel.
Mounting in application with Partition wall, that separates Zone 0 (Cat. 1G) from Zone 1 (Cat 2G).	VN ..030 with sliding sleeve: The use of the sliding sleeve is not allowed. VN ..040 and VN ..050: The unit has no safe separation between Zone 0 and Zone 1. It must be considered, that gas can pass from Zone 0 through the unit to Zone 1.

Mounting instructions

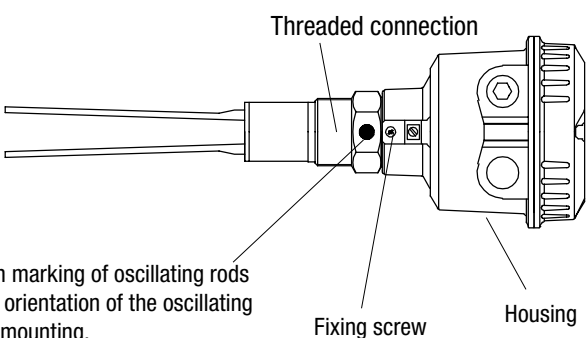
Oscillating rods	Do not bend, shorten or extend the oscillating rods since this will destroy the device.
Rotatable housing and orientation marking of oscillating rods (VN 5000/ 6000)	<p>The housing can be rotated against the threaded connection after mounting. For the d- and de- housing: Fixing screw must be unfastened to enable rotation. Fix the screw again, when the housing has the right position.</p> 
Direction of the cable glands	When the unit is mounted from the side, ensure, that the cable glands are closed and face downwards to avoid water penetrating the housing.
Sealing	Seal the 1½" thread with Teflon tape in case of process pressure
Switching point	Heavy bulk material -> the signal output switches, when the oscillating rods are covered a few mm. Light bulk material -> the signal output switches, when the oscillating rods are covered a few cm.

Mounting

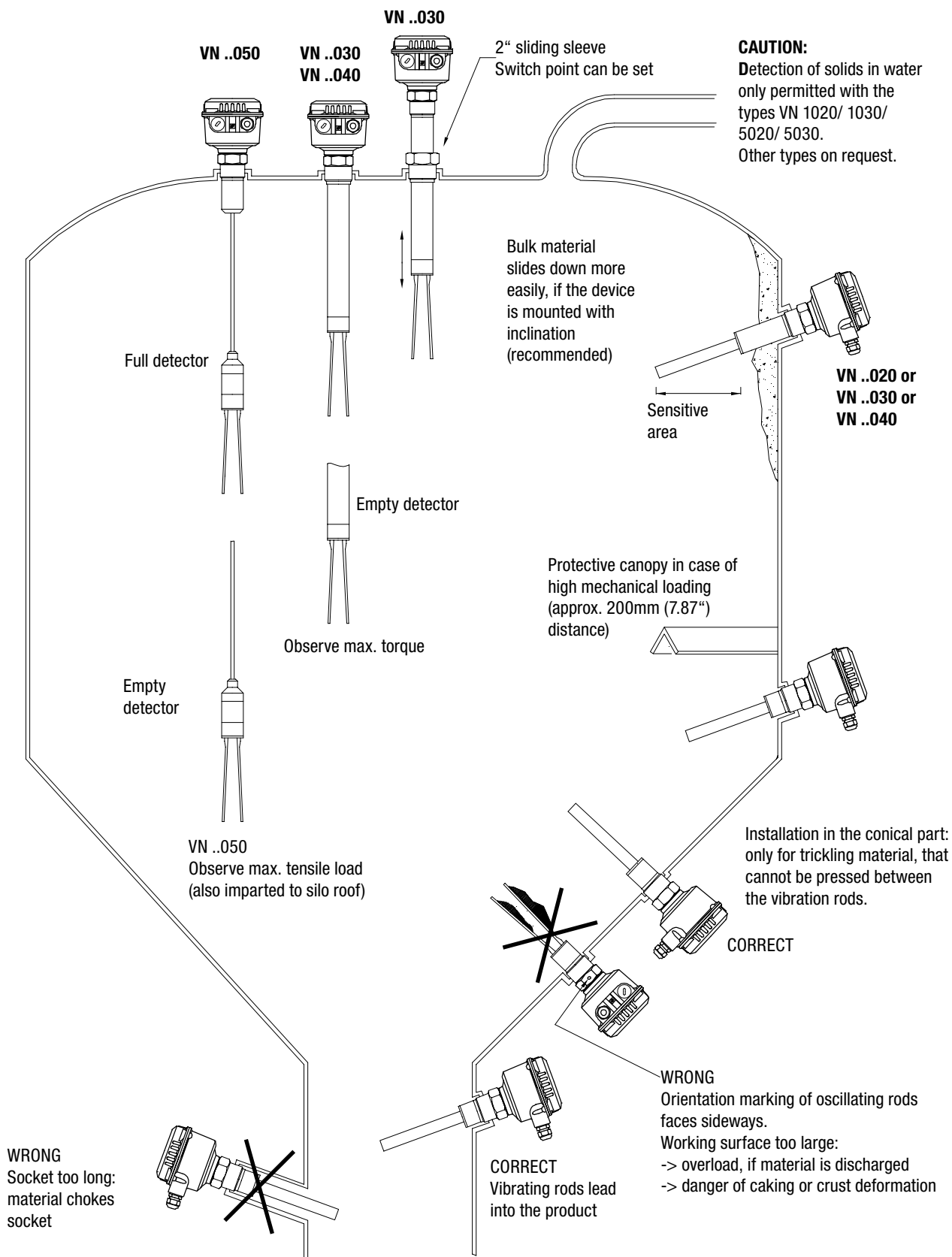

Electrical installation

General Safety Instructions

Handling	 In case of inexpert handling or handling malpractice, the electric safety of the device cannot be guaranteed.
Installation regulations	The local regulations or VDE 0100 (Regulations of German Electrotechnical Engineers) must be observed.
Fuse	Use a fuse as stated in the connection diagrams (page G19 and G20).
RCCB protection	In the case of a defect, the distribution voltage must automatically be cut off by a RCCB protection switch to protect the user of the device from indirect contact with dangerous electric tensions.
Power supply switch	A voltage-disconnecting switch must be provided near the device.
Wiring diagram	The electrical connections are made in accordance with the wiring diagram.
Supply voltage	Compare the supply voltage applied with the specifications given on the electronic module and name plate before switching the device on.
Cable gland	Make sure that the screwed cable gland safely seals the cable and that it is tight (danger of water intrusion). Cable glands that are not used have to be locked with a closing element.
Conduit system	In case of using a conduit system (with NPT thread) instead of a cable gland the regulations of the country, where the unit is installed, must be observed. The conduit must have a tapered thread either NPT 1/2" or NPT 3/4" in accordance with the unit and ANSI B 1.20.1. Not used inlets must be closed tight with a metal closing element.
Field wiring cables	All field wirings must have insulation suitable for at least 250V AC. The temperature rating must be at least 90°C (194°F).
Connecting the terminals	Make sure that max. 8mm (0.31") of the pigtails are bared (danger of contact with live parts).
Relay and transistor protection	Provide protection for relay contacts and output transistors to protect the device against inductive load surges.
Protection against static charging	The housing of the unit (and for the version VN ..020 with separate housing also the vibrating fork part) must be grounded to avoid static charging of the unit. This is particularly important for applications with pneumatic conveying and non-metallic containers .

Additional Safety Instructions for Hazardous Locations

Installation in Zone 0 (Electronics: „NAMUR“ and “8/16mA or 4-20mA”) The intrinsic safe supply circuit must have galvanic isolation to non intrinsic safe part. Otherwise measures for protection against lightning must be taken (see EN 60079-14).

Power supply (Electronics: „NAMUR“ and “8/16mA or 4-20mA”) The type of protection (intrinsic safe) is only valid when connecting to a certified intrinsic safe power supply (associated apparatus).

External equipotential bonding terminal Connect with equipotential bonding to the plant

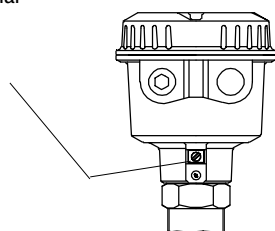

Version VN ..020 with separate housing must be grounded additionally at the vibrating fork.

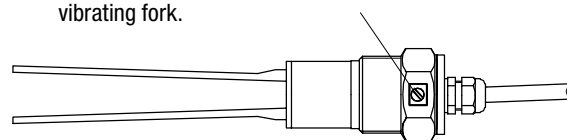

Electrical installation

Field wiring A strain relief must be provided for the field wiring cables, when the device is installed with the factory provided cable glands.

Cable glands for ATEX Dust and Gas Hazardous Locations Flameproof enclosure “d”:
 The cable entry devices of a flameproof enclosure “d” shall be of certified flameproof types of EEx “d” IIC, suitable for the conditions and correctly installed. Not used entries have to be closed with adequate blanking elements of certified flameproof types of EEx “d” IIC.

Increased Safety “e” (“de”) and Dust Hazardous enclosures:
 For increased safety “e” and dust hazardous applications, the cable entry devices and blanking elements are provided from the manufacturer and shall be in a certified type of explosion protection increased safety EEx “e” IIC or flameproof enclosure EEx “d” IIC. Not used entries have to be closed with adequate blanking elements of a certified increased safety type EEx “e” IIC or flameproof type EEx “d” IIC.

General requirements:
 The used entry devices and blanking elements must have an adequate type approval and a temperature range of at least -40°C (-40°F) to +80°C (176°F). In addition they shall be suitable for the conditions and correctly installed. Where applicable the provided original parts of the manufacturer must be used.

Conduit system for ATEX Dust and Gas Hazardous Locations Installation of a flameproof enclosure “d” with a conduit system:
 In a conduit system single electric conductors are installed in a certified pipe system. This pipe system is in a flameproof construction as well. The flameproof enclosure “d” and the pipe system needs to be sealed from each other by a certified flameproof seal of a type EEx “d” IIC. This flameproof seals shall be installed directly in or at the conduit entries of the flameproof enclosure “d”. Not used entries have to be closed with adequate blanking elements of a certified flameproof type EEx “d” IIC.

General requirements:
 In addition the regulations of the country must be observed. The used flameproof seals and blanking elements must have an adequate type approval and a temperature range of at least -40°C (-40°F) to +80°C (176°F). In addition they shall be suitable for the conditions and correctly installed. Where applicable the provided original parts of the manufacturer must be used.

Conduit system for FM and CSA Dust and Gas Hazardous Locations Installation of a flameproof enclosure “d” with a conduit system:
 In a conduit system single electric conductors are installed in a certified pipe system. This pipe system is in a flameproof construction as well. The flameproof enclosure “d” and the pipe system needs to be sealed from each other by a certified flameproof seal. Conduit entries of a flameproof enclosure “d” shall have installed the flameproof seal within 18 inches from the enclosure wall. Not used entries have to be closed with adequate blanking elements of a certified flameproof type AEx Cl.1 Div.1 A.

General requirements:
 In addition the regulations of the country must be observed. The used flameproof seals and blanking elements must have an adequate type approval and a temperature range of at least -40°C (-40°F) to +80°C (176°F). In addition they shall be suitable for the conditions and correctly installed. Where applicable the provided original parts of the manufacturer must be used.

Commissioning Commissioning only with closed lid.
 Exception: Units with protection method Intrinsic safety (“NAMUR” and “8/16mA or 4-20mA”)

Opening the lid



Units with flameproof GasExplosion approval (d-housing):
 To prevent ignition of hazardous atmospheres, do not remove the lid (cover) while circuits are alive.

Units with Dust Explosion approval:
 Before opening the lid ensure, that no dust deposits or cloudss are present.
 Do not remove the lid (cover) when the power is live.

Units with protection method Intrinsic safety (“NAMUR” and “8/16mA or 4-20mA”):
 The lid can be removed when the power is live.

Electrical installation

Connection

VN 1000/ 2000: Standard-housing

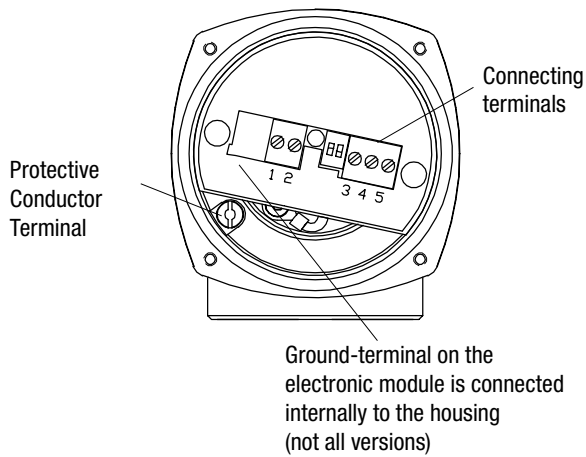

VN 5000/ 6000: Standard- and d-housing

Connection is done directly on the Electronic module

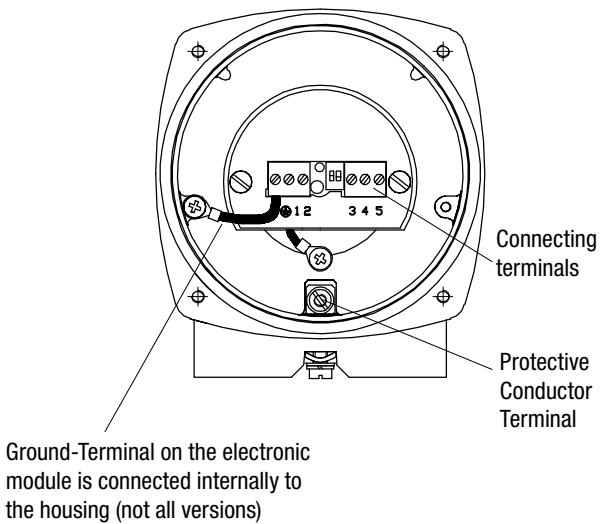

de-housing

Connection via the terminals inside the increased safety area.

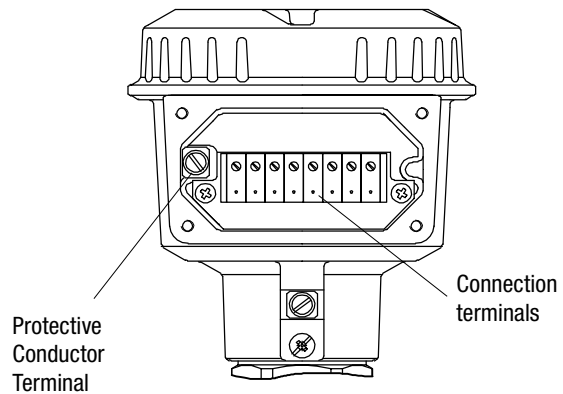

Electrical installation

Universal voltage

Relay SPDT

Power supply:

19..230V 50-60Hz +10% 8VA
 19..55V DC +10% 1,5W

Signal output:

Floating relay SPDT

VN 1000/ 2000:

AC max. 253V, 4A, 500VA at $\cos \Phi = 1$
 DC max. 253V, 4A, 60W

VN 5000/ 6000:

AC max. 250V, 8A, non inductive
 DC max. 30V, 5A, non inductive

Fuse on signal output: max 10A

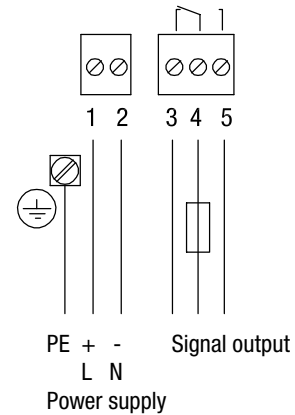

Universal voltage

Relay DPDT

Power supply::

19..230V 50-60Hz +10% 18VA
 19..55V (36V*) DC +10% 2W

Signal output:

Floating relay DPDT

VN 1000/ 2000:

AC max. 253V, 4A, 500VA at $\cos \Phi = 1$
 DC max. 253V, 4A, 60W

VN 5000/ 6000:

AC max. 250V, 8A, non inductive
 DC max. 30V, 5A, non inductive

Fuse on signal output: max 10A

* Version with intrinsic safe connection
 between electronic module and vibration fork
 (see pos.4 in pricelist)

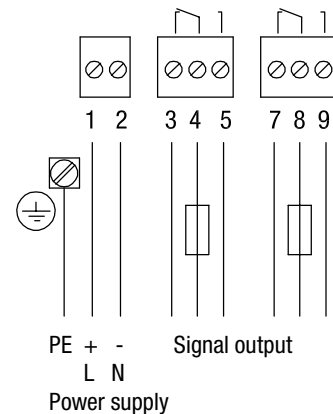

3-wire

PNP

Power supply:

18 .. 50V DC +10% 1,5W

Fuse: max 4A

Signal output:

max. 0,4A

Load for example:
 PLC, relay, contactor, bulb

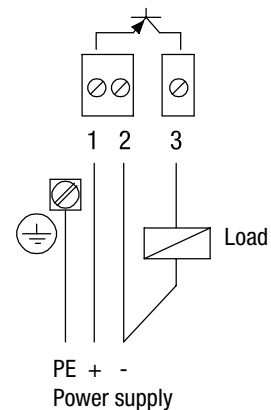

Electrical installation

2-wire

without contact

Power supply:

19..230V 50/60Hz +10% 1,5VA
 19..230V DC +10% 1W

Load:

max. 0,5A permanent
 (detailed ratings see
 "Technical data")

Load for example:
 relay, contactor, bulb

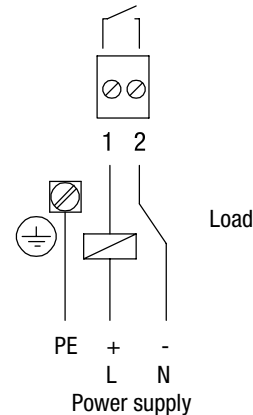

NAMUR IEC 60947-5-6

Power supply:

ca. 7..9 V DC
 intrinsic safe
 (spec. IEC 60947-5-6)

<1mA or > 2,2mA
 (spec. IEC 60947-5-6)

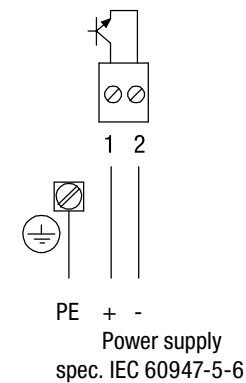

8/16mA or 4-20mA

Power supply:

Non intrinsic safe version:
 12,5..36V DC +0%

Intrinsic safe version:
 12,5..30V DC +0%

Signal output

Setting 8/16mA:
 8mA or 16mA

Setting 4-20mA:
 Output current depends on the vibration
 amplitude of the fork: 6mA for dampened
 vibration and 20mA for full vibration.

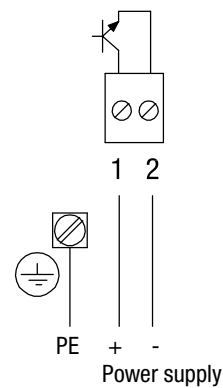

8/16mA

Power supply:

12,5..36V DC +0%

Signal output

8mA or 16mA

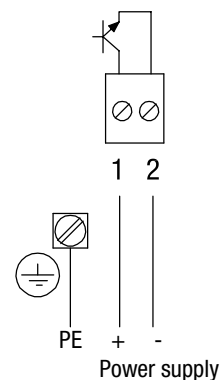

Signal output

Electronic modules: FSL / FSH or Characteristic Setting

Universal voltage
 (Relay SPDT and DPDT)

3-wire
 PNP

2-wire
 without contact

8/16mA

NAMUR
 (IEC 60947-5-6)

Remark: „FSH/FSL“ is used for electronic modules:
 Universal voltage, 3-wire, 2-wire
 "Characteristic" is used for electronic module:
 NAMUR

FSH



If the sensor is used to indicate full load, set to Fail Safe High or Falling Characteristic. Power failure or line break is regarded as „full“ signal (protection against overcharging).

FSL



If the sensor is used to indicate empty load, set to Fail Safe Low or Rising Characteristic. Power failure or line break is regarded as „empty“ signal (protection against running dry).

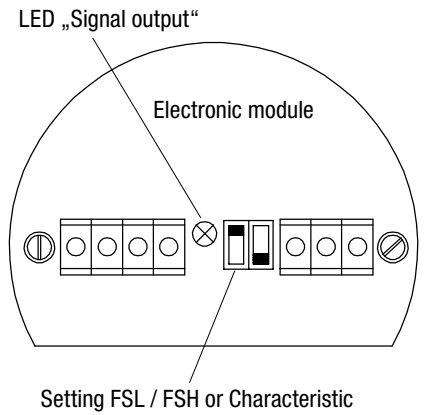

Signal output

Setting	FSL	FSH
Relay SPDT		
Relay DPDT		
3-wire PNP		
2-wire without contact		
8/16mA	I = 16mA	I = 8mA
LED „Signal output“		

Signal output

Setting	FSL	FSH
NAMUR IEC 60947-5-6		
LED „Signal output“		

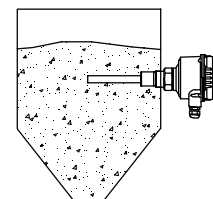
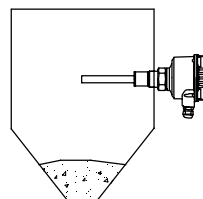

Signal output delay / Diagnosis

Signal output delay

Electronic module
Universal voltage
 (Relay DPDT)

Signal output delay

The signal output can be delayed, adjustable from 0 upto ca. 30 seconds. Clockwise turning of the potentiometer increases the delay time.

Potentiometer T1:
 Delay when output switches from sensor covered -> free

Potentiometer T2:
 Delay when output switches from sensor free -> covered

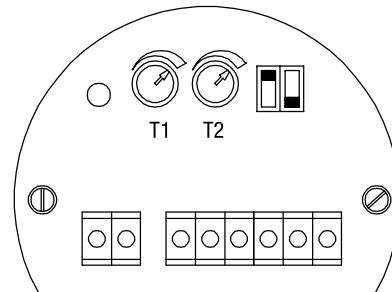

Diagnostics

Electronic module
NAMUR
 (IEC 60947-5-6)

“TEST” Button

If the sensor is not covered with material:

By pressing this button, the vibration will stop and the signal output will switch to indicate “covered sensor”. This allows to test the vibration and the electronics for function without removing the sensor from the silo.
 Remark: By pressing the button, the internal signal from the piezo-element, that indicates the vibration of the fork, is shortened. The electronics miss the vibration signal and indicates “covered sensor”.

If the sensor is covered with material:

Pressing of this button has no effect.

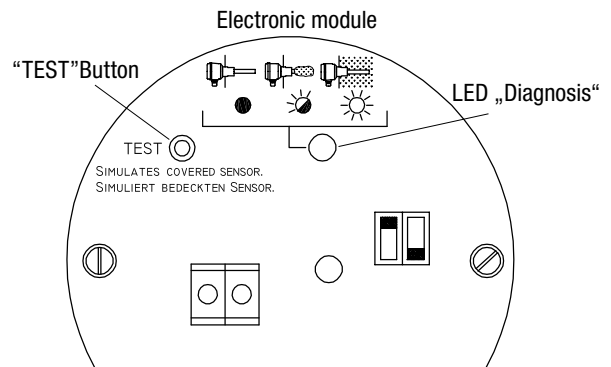

Weak vibration Diagnosis: LED “Diagnosis”

The quality of the measurement is related to the vibration amplitude of the sensor and can be evaluated by the internal LED „Diagnose“ as follows:

- **Safe measurement, clean fork (LED is off):**
 The vibration amplitude is strong. There is enough safety to the switching point.
- **Weak vibration amplitude (LED is blinking):**
 The sensor is still working but it can happen that gradually the amplitude decreases further (maybe by increasing material buildup) and the measurement fails. If low vibration amplitude is indicated the sensitivity setting should be changed from „20g/l“ to „75 g/l“ (or from „5g/l“ to „20g/l“ on version with enhanced sensitivity) if material density is not too low and the fork should be cleaned from material.
 Remark: By shifting the setting to “75g/l” (or to „20g/l“ on version with enhanced sensitivity), the internal amplification of the vibration signal in the electronic is increased. This allows more build up of material.
- **Fork fully covered (LED is on):**
 The sensor is fully covered with material. The vibration has stopped.

Signal output and Diagnosis

Electronic module
8/16mA or 4-20mA

The output can either be set to give 8/16mA or to give 4-20mA. On setting 4-20mA the output depends on the amplitude of the vibration of the fork.

Characteristic setting

▼ If the sensor is used to indicate full load, set to Falling Characteristic. Power failure or line break is regarded as „full“ signal (protection against overcharging).

▲ If the sensor is used to indicate empty load, set to Rising Characteristic. Power failure or line break is regarded as „empty“ signal (protection against running dry).

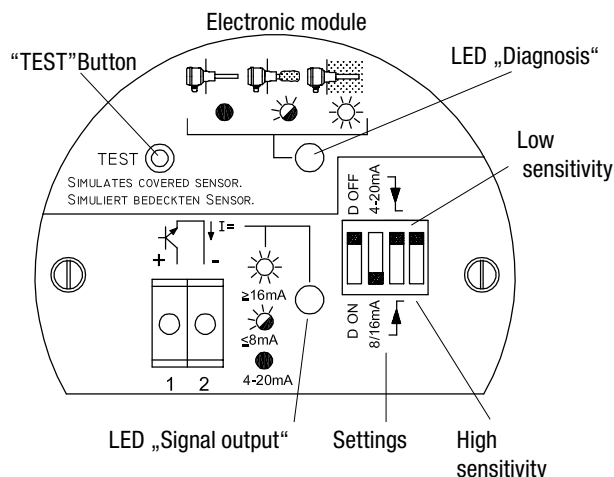

	Low sensitivity	High sensitivity
VN 1000/ 5000	150g/l (9lb/ft ³)	50g/l (3lb/ft ³)
VN 2000/ 6000	75g/l (4,5lb/ft ³)	20g/l (1.2lb/ft ³)
VN 2000/ 6000 with enhanced sensitivity	20g/l (1.2lb/ft ³)	5g/l (0.3lb/ft ³)

Weak vibration diagnosis

The quality of the measurement is related to the vibration amplitude of the sensor and can be evaluated by the output current and by the internal LED „Diagnosis“ as follows:

- **Safe measurement (clean fork):**

The vibration amplitude is strong. There is enough safety to the switching point.

- **Weak vibration amplitude:**

A fork with so much material buildup, that a weak vibration amplitude is indicated.

The sensor is still working, but it can happen, that gradually the amplitude decreases further (maybe by increasing material buildup) and the measurement fails. If low vibration amplitude is indicated, the sensitivity setting should be changed from „High sensitivity“ to „Low sensitivity“, if material density is not too low, and the fork should be cleaned from material. Remark: By shifting the setting to „Low sensitivity“, the internal amplification of the vibration signal in the electronic is increased. This allows more build up of material.

- **Fork fully covered:**

The sensor is fully covered with material. The vibration has stopped.

“TEST” Button

If the sensor is not covered with material:

By pressing this button, the vibration will stop and the signal output will switch to indicate “covered sensor”.

This allows to test the vibration and the electronic for function without removing the sensor from the silo.

Remark: By pressing the button, the internal signal from the piezo-element, that indicates the vibration of the fork, is shortened. The electronic misses the vibration signal and indicates “covered sensor”.

If the sensor is covered with material:

Pressing of this button has no effect.

Factory provided settings

- D OFF
- 8/16mA
- ▼
- High sensitivity

Signal output and Diagnosis

Electronic module
8/16mA or 4-20mA

Output setting: 8/16mA

The figure illustrates the output current depending on the situation with:

- Safe measurement (clean fork).
- Weak vibration amplitude: a fork with so much material buildup, that a weak vibration is indicated.
- Fork fully covered.

The output current can indicate the weak vibration with diagnose setting „D ON“.

Diagnosis off (setting „D OFF“):

The output changes between 8mA and 16mA.

Diagnosis on (setting „D ON“):

The output will change from 16mA to 20mA and from 8mA to 6mA, if the vibration is weak. This enables an evaluation on an external 4-20mA power supply. There is an internal delay of 10 seconds, until the change from 16mA to 20mA and from 8mA to 6mA happens, so that the external power supply does not indicate „weak vibration“, when the vibration is stopped and is started during normal (safe) measurement operation.

Characteristic setting						
D setting	D ON	I= 16mA	I= 8mA	I= 16mA	I= 8mA	I= 8mA
	D OFF			I= 20mA	I= 6mA	I= 16mA
LED „Signal output“						
LED „Diagnosis“						

Example of evaluating the diagnosis of weak vibration amplitude:

Connection of an external Limit Value Monitor with 4-20mA input and two relay outputs.
 (Fitting units can be ordered as accessories, see pricelist)

Relay 1 indicates the situation: Full / empty.

Relay 2 works as a Diagnose output to indicate: Safe measurement / Non safe measurement (weak vibration).

Relay 1:
 Full/empty
 Set switching point to **10mA**.

Relay 2:
 Diagnosis
 Set switching point to:

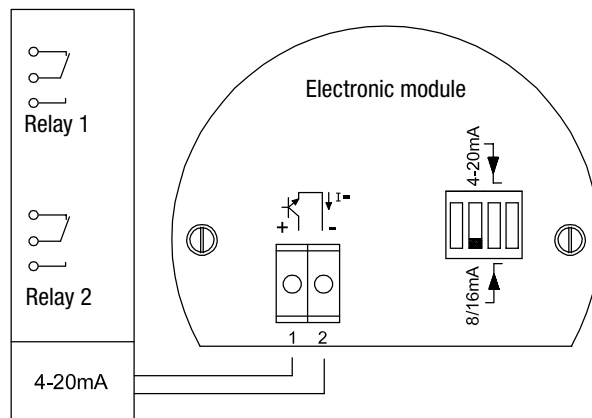
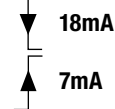

External Limit Value Monitor with 4-20mA input and two relay outputs.

Signal output and Diagnosis

Electronic module
8/16mA or 4-20mA

Output setting: 4-20mA

The output states the quality of the vibration signal (amplitude) of the sensor. With the 4-20mA setting it is possible, to recognize material buildup on the vibrating fork by evaluation with a PLC. Furthermore it is possible to evaluate the vibration behaviour for critical applications by using a 4-20mA Data logger or PLC.

Remark

In this mode:

- The switch „D ON“ or „D OFF“ has no influence.
- The LED „Signal output“ is off.

Output current:

- 20mA:
 The vibration amplitude is strong (safe measurement, clean fork). With interface measurement (VN10..0 und VN50..0) a max. vibration amplitude of approx. 15mA occurs.
- < 20mA and >12/12.5mA:
 The vibration amplitude is decreased by material buildup or mechanical influence. On setting „Low sensitivity“ the material buildup must be more to decrease the output current compared to setting „High sensitivity“.
- <12/12.5mA and >7/8mA:
 The recommended range indicate a weak vibration. This is also the range, where the internal LED „Diagnosis“ starts blinking to indicate a weak vibration. Depending on the application this value can be changed in the PLC.
 The evaluation in the PLC should be done so, that a window between 12/12.5mA and 7/8mA is set. The reaction to indicate „weak vibration“ should be delayed for approx. 10 seconds, so that the indicator does not happen when the vibration is stopped and is started during normal and safe measurement operation.
 A lag of 0.5mA (between 12mA and 12,5mA) should be considered to avoid jittering of the output.
- 7/8mA:
 The recommended point to indicate a covered sensor. The point is close to the stop of the vibration at 6mA. Depending on the application this point can be changed in the PLC.
 A delay of 1mA (between 7mA and 8mA) should be considered to avoid jittering of output.
- 6mA:
 The vibration has fully stopped.

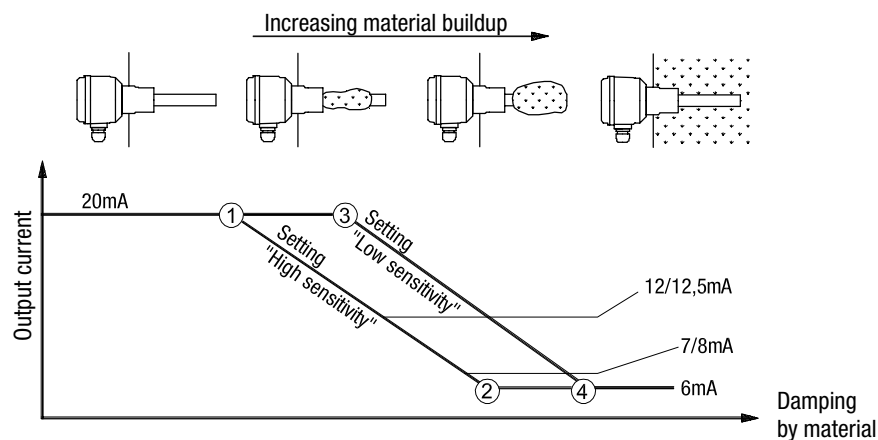

With setting „High sensitivity“:

- ① Amplitude is 100%
- ② Amplitude is 0%

With setting „Low sensitivity“:

- ③ Amplitude is 100%
- ④ Amplitude is 0%

Setting: Sensitivity / Maintenance

All Electronic modules

Sensitivity

All sensors are factory preset. Normally it is not necessary to change the settings. If the bulk material has a strong tendency to cake or deposit the setting switch can be set to position „A“ to decrease the sensitivity of the probe (factory presetting = position „B“).

Approximate min. bulk density on setting:

	A Low sensitivity	B High sensitivity
VN 1000/ 5000	150g/l (9lb/ft³)	50g/l (3lb/ft³)
VN 2000/ 6000	75g/l (4.5lb/ft³)	20g/l (1.2lb/ft³)
VN 2000/ 6000 with enhanced sensitivity	20g/l (1.2lb/ft³)	5g/l (0.3lb/ft³)

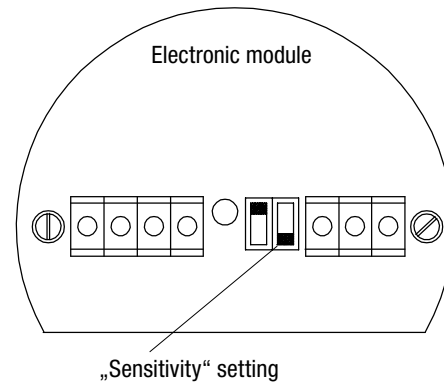

VN 1000/ 5000:

For measurement of solids in water setting „A“ is recommended or to take the electronic with potentiometer.

Option interface measurement

(Sensitivity adjustable with potentiometer)

Turn to Min: Vibrating fork gets less sensitive

Turn to Max: Vibrating fork gets more sensitive

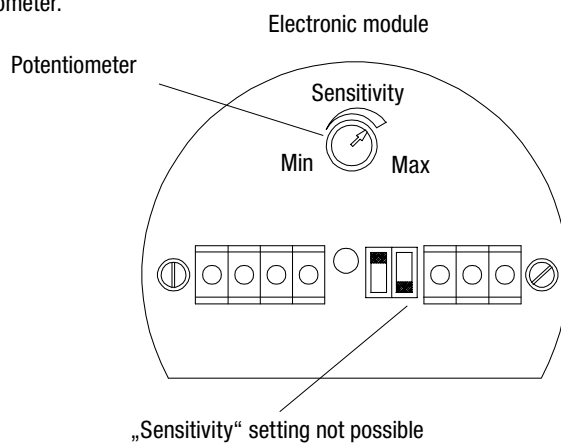

Maintenance

Normally, the device requires no maintenance. However, depending on the application, the following should be observed and inspected:

- Mechanically damaged oscillating rods.
- Mechanically damaged extension rope (VN ..050).
- Coarse cleaning of the vibrating fork.

Changing the Electronic module

Intrinsic safe marked Electronic modules are not allowed to be exchanged with Electronic modules without Intrinsic safe marking. Observe warning labels inside the housing and Ex marking on the name plate.

1. Open the housing lid, remove the pigtails from the device.
2. Disconnect internal wire for earth connection (not on all versions).
3. Unscrew two fastening screws of the electronic module.
4. Pull out the Electronic module.
5. Insert a new Electronic module (until it locks into place) and tighten fastening screws.
6. Connect internal wire for earth connection (not on all versions).
7. Connect the pigtails to the device.

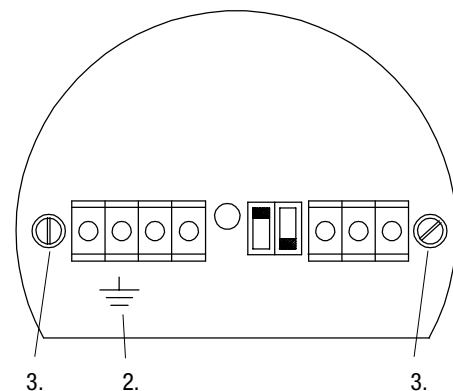

Notes for use in Hazardous Locations

ATEX Zone classification

	category	usable in zone
Dust applications	1 D	20, 21, 22
	2 D	21, 22
	3 D *	22
Gas applications	1 G	0, 1, 2
	2 G	1, 2
	3 G	2

* in case of conductive dust additional requirements for the installation may be necessary

General Notes

Marking

Devices with Ex approval are marked on the name plate.

Process pressure for ATEX



The device construction allows process over-pressure upto 6/10 bars (87/145psi) (see name plate). These pressures are allowed for test purposes. The definition of the ATEX is only valid for a container-over-pressure between -0.2..+0.1 bar (-2.9..+1.45psi). For higher or lower pressures the approval is not valid.

Process and ambient temperature

The permitted temperature ranges are marked on the name plate.

Notes for use in Hazardous Locations

Permitted zones (categories) for mounting in partition wall

Version with standard-housing

(VN 1000 / 2000 / 5000 / 6000)

With use of Electronic module:

Universal voltage Relay SPDT	NAMUR IEC 60947-5-6
Universal voltage Relay DPDT	(intrinsic safe) *
3-wire PNP	8/16mA or 4-20mA
2-wire without contact	(intrinsic safe) *
8/16mA or 4-20mA	
(non intrinsic safe)	

Category (ATEX) Zone	↓	2D	1D	2D	1G	2G **
		21	20	21	0	1
Category (ATEX) Zone		1D	1D	1D	1G	1G
		20	20	20	0	0

* The units are marked on the name plate with "1G" and "1D".
 They can be also mounted in a partition wall with specification
 1/2G and 1/2D.

** VN ..040 and VN ..050:

When mounting the units in a partition wall, that separates
 Zone 0 (Cat. 1G) from Zone 1 (Cat 2G): The units have no safe
 separation between Zone 0 and Zone 1. It must be considered,
 that gas can pass from Zone 0 through the unit to Zone 1.

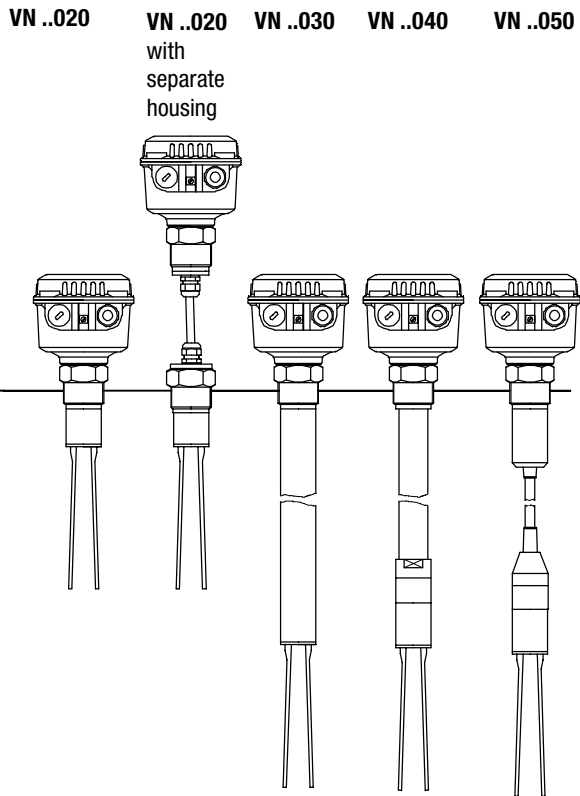

Version with d- and de-housing

(VN 5000 / 6000 ; flameproof/increased safety)

With use of all Electronic modules:

Universal voltage Relay SPDT
3-wire PNP
2-wire without contact

Category (ATEX) Zone	2G	2D
	1	21
Category (ATEX) Zone	2G	1D
	1	20

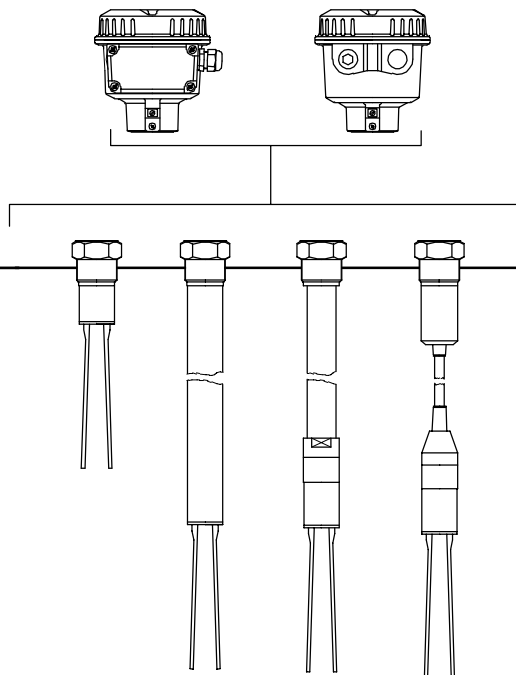

Notes for use in Hazardous Locations

Max. surface temperature and temperature class

The temperature marking on the name plate  refers to the instruction manual.
 On the following tables the relevant temperature ratings are shown.

The maximum surface temperature refers to the warmest area outside on the unit which can occur in failure case (according to EX definition).
 The temperature class refers to the warmest area anywhere outside or inside the unit which can occur in failure case (according to EX definition).

The data tables are valid, when it can be guaranteed during installation that the screwed connection has a maximum temperature of 80°C (176°F) during normal use.

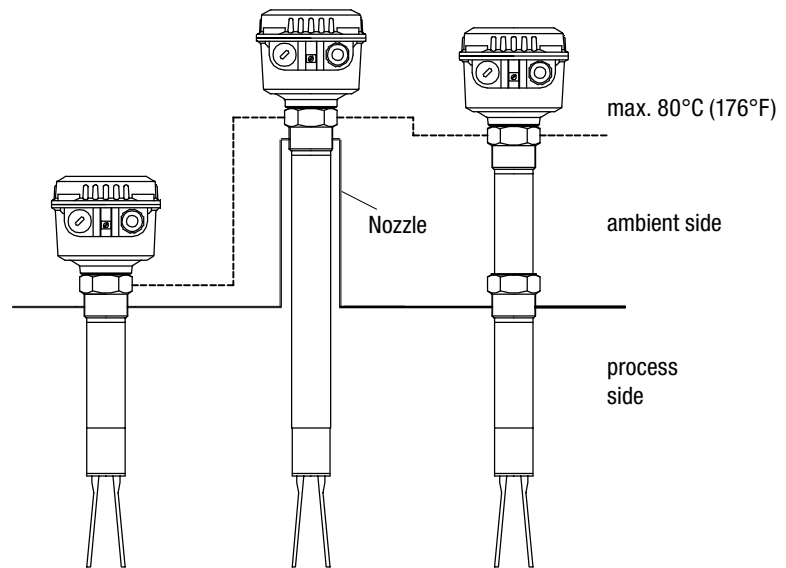

Ratings on the different versions

VN 1000 / 2000:

Maximum surface temperature:

The maximum surface temperature is considered for Dust Ex approvals. It refers to the warmest area outside on the unit which can occur in failure case (according to ATEX definition).

Maximum surface temperature in zone 21	Maximum surface temperature in zone 20	Ambient temperature in zone 21	Process temperature in zone 20
100°C (212°F)	90°C (194°F)	60°C (140°F)	90°C (194°F)
	100°C (212°F)		100°C (212°F)
	110°C (230°F)		110°C (230°F)
	120°C (248°F)		120°C (248°F) ⁽¹⁾
	130°C (266°F)		130°C (266°F) ⁽¹⁾
	140°C (284°F)		140°C (284°F) ⁽¹⁾
	150°C (302°F)		150°C (302°F) ⁽¹⁾

Temperature class:

The temperature class is valid for Gas Ex approvals. It refers to the warmest area anywhere outside or inside the unit which can occur in failure case (according to ATEX definition). This table is relevant for units with intrinsic safe electronic modules.

Temperature class	Ambient temperature	Process temperature
T6	60°C (140°F)	80°C (176°F)
T5		95°C (203°F)
T4		130°C (266°F) 110°C (230°F) for types with separate housing
		150°C (302°F)
T3		

(1) not for VN ..020 with separate housing

Notes for use in Hazardous Locations

VN 5000 / 6000:

Max. ambient temperature	Process temperature	Process side			Umgebungsbereich		
		Max. surface temperature	Temperature class (Division system)	Temperature class (Zone system)	Max. surface temperature	Temperature class (Division system)	Temperature class (Zone system)
60°C (140°F)	80°C (176°F) ⁽¹⁾	85°C (185°F)	T6	T6	85°C (185°F)	T6	T6
	100°C (212°F) ⁽²⁾	100°C (212°F)	T5	T5	100°C (212°F)	T5	T5
	110°C (230°F) ⁽²⁾	110°C (230°F)	T4A	T4			
	120°C (248°F) ^{(2) (3)}	120°C (248°F)	T4A	T4			
	130°C (266°F) ^{(2) (3)}	130°C (266°F)	T4	T4			
	140°C (284°F) ^{(2) (3)}	140°C (284°F)	T3C	T3			
	150°C (302°F) ^{(2) (3)}	150°C (302°F)	T3C	T3			

(1) only with use of electronic module „NAMUR IEC 60947-5-6“ or “8/16mA or 4-20mA”

(2) not for VN ..050

(3) not for VN ..020 with separate housing

Assembly VN ..040

Manufacturing of the Extension tube

! Obtain instruction manual for proper manufacturing of the extension tube. In case of deviation from the instruction manual the unit is not safe for use in Hazardous Locations.

Demands on the Extension tube

Material: Stainless steel 1.4301 (SS304) or 1.4305 (SS301) or 1.4571 (SS316Ti) or 1.4404 (SS316L)

The tube must be manufactured from one single piece. It is not allowed to weld two or more pieces together.

Carefully observe max. length, diameter, wall thickness, thread, tolerances as specified in the drawing.

All sharp edges must be removed to protect the cable and sealing rings.

Thread testing

Each thread must be tested with no-go ring gauge according to standard DIN ISO 228-1 (G1") (G-version) or ANSI B 1.20.1 (NPT 1") (NPT version)

Version with G1" (DIN ISO 228-1) thread (selection pricelist pos.5 A,L,M)

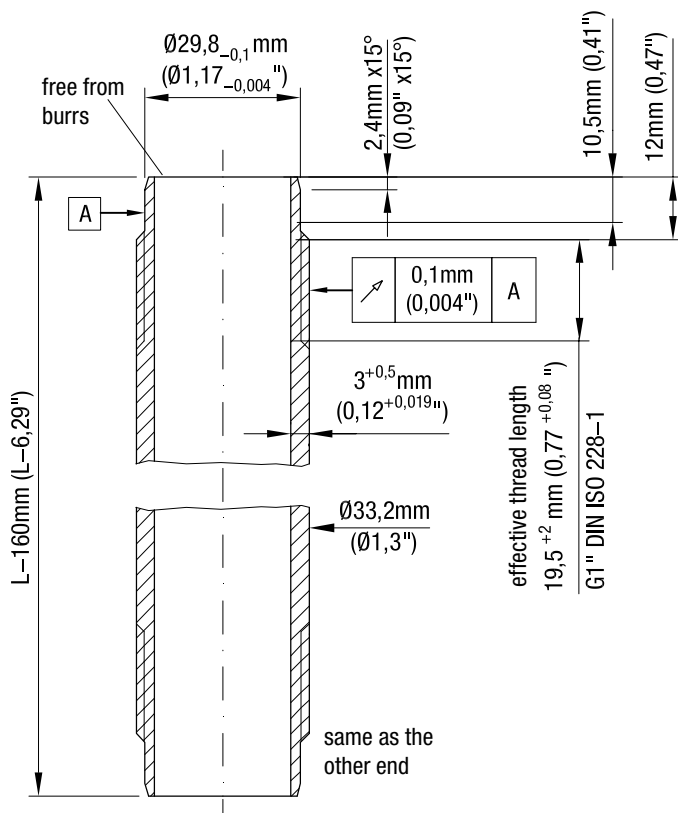

Version with 1" (ANSI B 1.20.1) NPT thread (selection pricelist pos.5 B,S,T,U)

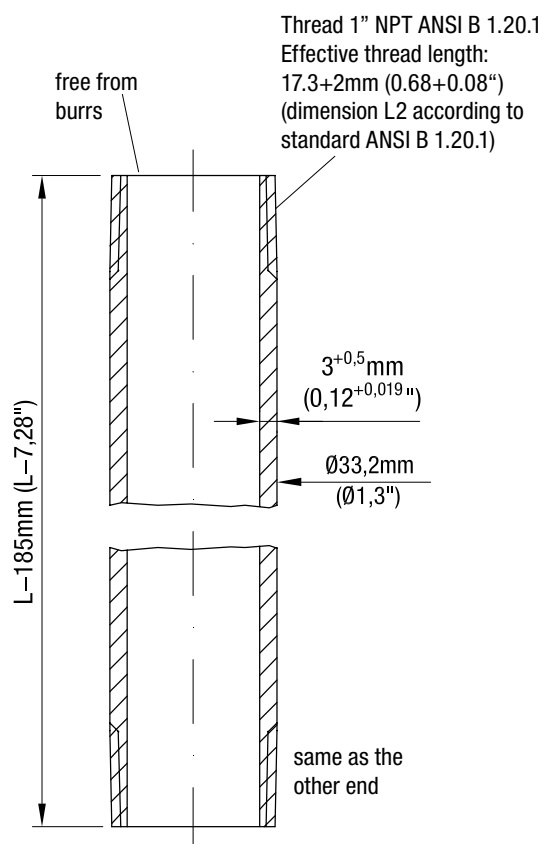

Assembly VN ..040 with Standard housing

Assembly of the unit

1. Mounting of the Extension tube

! The tube must be assembled very carefully to ensure permanent sealing and mechanical stability.
 • Observe the follow mounting instructions.

! Make sure that the thread of the extension tube and the thread of the screwed piece/oscillating piece is the same type (do not mix G and NPT thread).

1.1. Feed the connecting wire through the 1" Extension tube and the screwed piece. Use a separate taut wire for easy working.

1.2. Screw the 1" Extension tube into the oscillating piece and the screwed piece. Use a 36mm (1.42") open-end wrench to attach the fork piece (do not use the forks).

G version: Tighten the 2 fixing screws.

Sealing:

There must be tight connections at both ends of the extension tube.

G version: An o-ring is required at both ends to ensure proper sealing and must not be damaged. Only original o-rings from the manufacturer are allowed to be used.

NPT version: The threads must be sealed with temperature resistant sealing for 150°C (302°F).

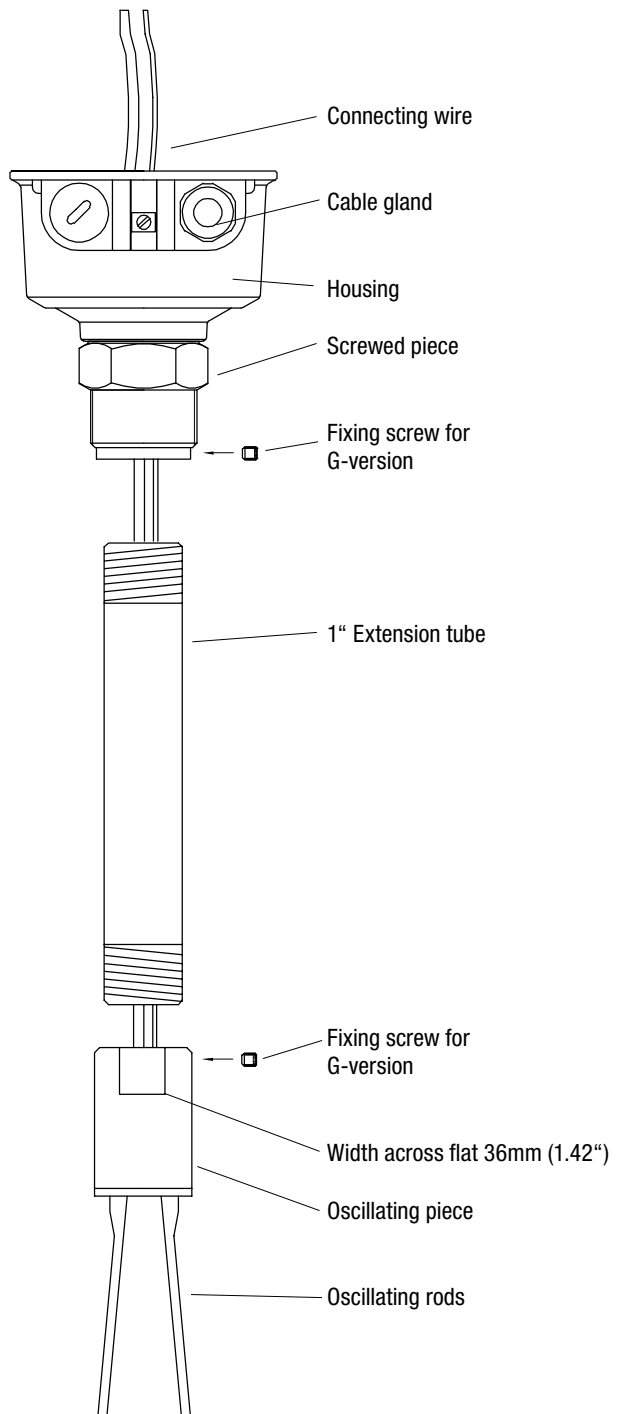

Assembly VN ..040 with Standard housing

2. Preparing the cables

Shorten the earth cable to 220mm (8.66") and sensor cables to 150mm (5.9"). Prepare cables as shown.

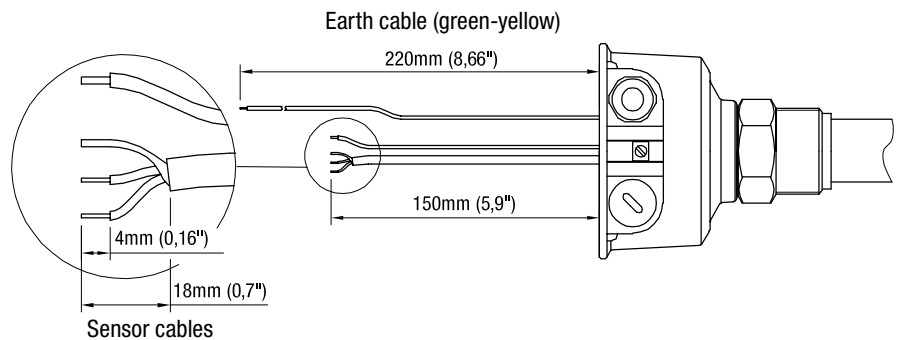

3. Connecting the cables

Connect sensor cables to the terminal connection piece. Fix the cables with cable clamps. Connect electronic module and terminal connection piece. Be sure that all terminals are tightly screwed in.

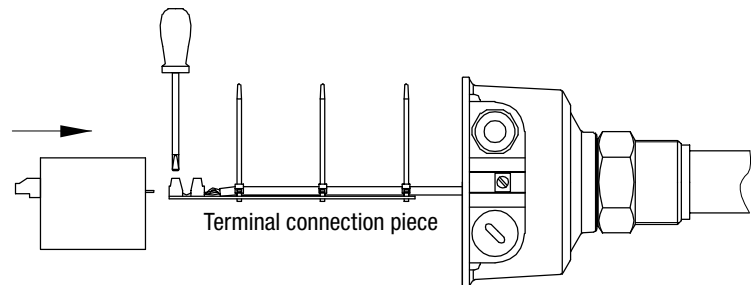

Connect the earth cable from the vibrating fork to the housing (see figure at the bottom of this page).

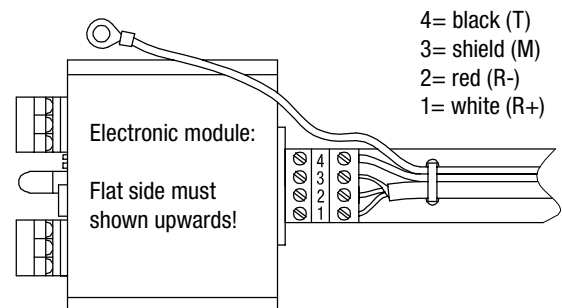

4. Fixing the electronic module

Insert electronic module into housing. The terminal connection piece is used to guide the cables. Fold connection cables as shown. Use cylinder head screws to fix the electronic module.

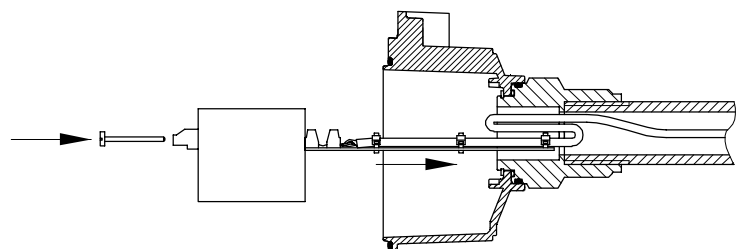

Connect the earth cable from the electronic module to the housing (not on all versions).

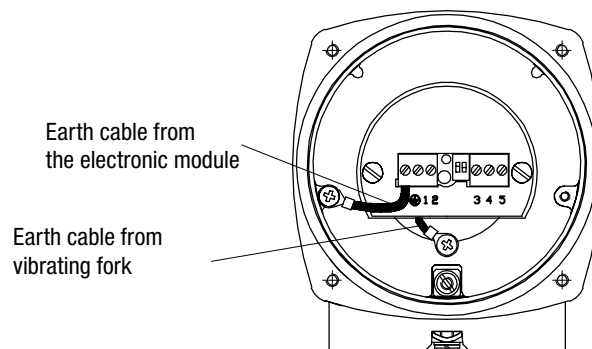

Assembly VN 5040/ 6040 with d or de-housing

Assembly of the unit

1. Mounting of the Extension tube to oscillating piece and preparing cables

- ! **The tube must be assembled very carefully to ensure permanent sealing and mechanical stability. Observe the follow mounting instruction.**
- ! **Make sure, that the thread of the extension tube and the thread of the screwed piece/oscillating piece is the same type (do not mix G and NPT thread).**
- ! **Before starting mounting, check if an intrinsic safe oscillating piece is provided. To avoid mixing with other types, these pieces are marked with a label "Intrinsic safe circuit" as shown on the drawing (the label is fixed to the sensor cables directly on the oscillating piece). This marking guaranties that the provided oscillating piece is correct. Not marked oscillating pieces are not allowed to use.**

- 1.1. Feed the connecting wire through the 1" Extension tube. Use a separate taut wire for easy working.
- 1.2. Screw the 1" Extension tube into the oscillating piece. Use a 36 mm (1.42") open-end wrench, do not turn the oscillating rods.

G version: Tighten the Fixing screw

Sealing:

There must be a seal connection between the 1" tube and the screwed piece and the oscillating piece.

G version: An o-ring is required at both ends to ensure proper sealing and must not be damaged. Only original o-rings from the manufacturer are allowed to be used.

NPT version: The thread must be sealed with temperature resistant sealing for 150°C (302°F).

- 1.3. Shorten all cables to 80 mm (3.15"). Prepare cables as shown.

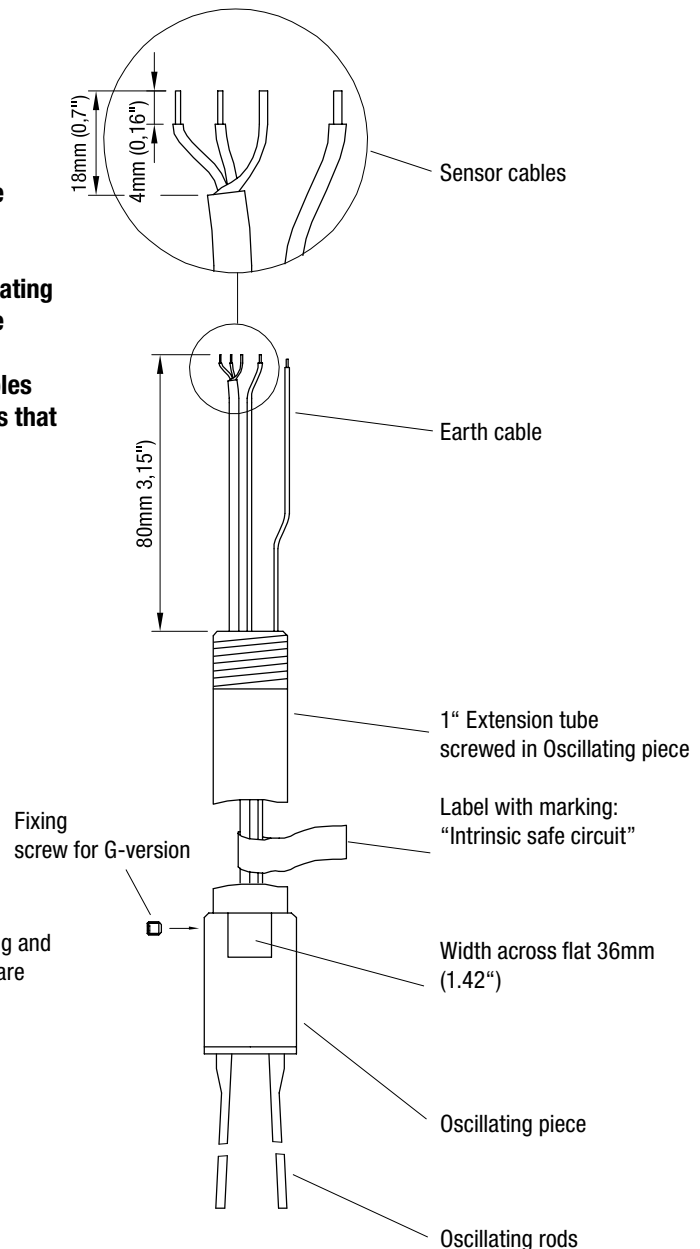

Assembly VN 5040 / 6040 with d or de-housing

2. Soldering the cables

Guide the big shrink hose over all cables.

Guide the small shrink hose over each cable.

Solder the cables as shown.

Shrink the small shrink hose with a hot air blower. Ensure that the exposed wires are all covered with shrink hose

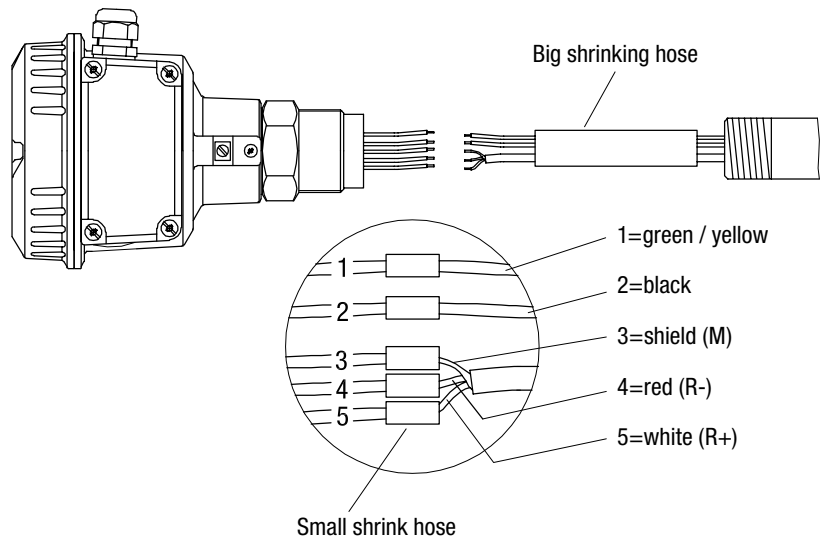

3. Shrinking all cables

Push the big shrink hose over the small shrink hoses and shrink with a hot air blower.

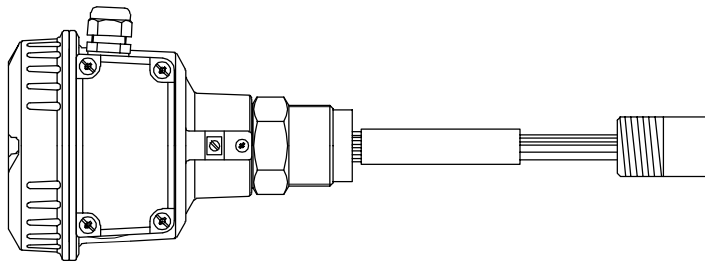

4. Mounting of the extension tube to housing side

Push the cables carefully into the extension tube.

Screw the 1" Extension tube into the screwed piece. Use a 36 mm (1.42") open-end wrench, do not turn the oscillating rods.

G version: Tighten the fixing screw

Sealing: see 1.2

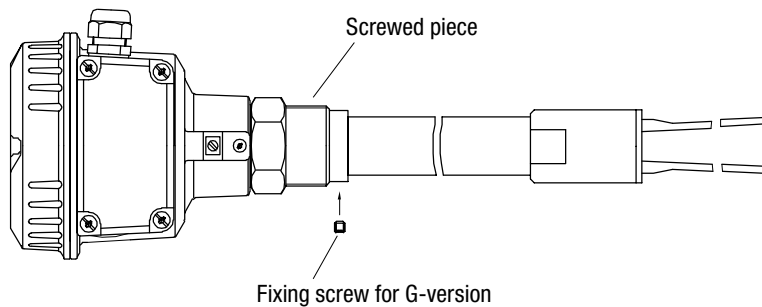

Assembly: VN ..020 with separate housing

Assembly vibration fork/housing

! Before starting mounting, check if an intrinsic safe oscillating piece is provided. To avoid mixing with other types, these pieces are delivered with a directly assembled cable gland. This existing cable gland guarantees that the provided oscillating piece is correct. Oscillating pieces without a directly mounted cable gland are not allowed to use.

1. Remove electronic module.
2. For version with Ex approval:
Feed connecting wire through the delivered metal hose or through a metal tube.

! To avoid static discharge and to provide mechanical protection of the connection cable, the connection cable must be installed inside the delivered metal hose or inside a robust metal tube (steel, inner diameter 10..14mm (0.39..0.55")). The metal hose or metal tube must cover the whole length of the connection cable close to the cable glands. The metal hose or metal tube must be grounded and robustly mounted. Ensure that the connection wire is not damaged by sharp edges of the metal tube or the metal hose.

3. Feed connection cable through the cable gland at the housing.
4. Connect connection cable to the plug. Obtain right connecting sequence (see drawing).
5. Connect plug to the electronic module.
6. Fix electronic module into the housing with 2 screws. To do this, move connecting cable with electronic module downwards. Take care, that the plug is not removing.
7. Tighten the cable gland on the housing.

! The cable gland on the housing used for the connecting cable must be done up tightly, so ingress protection IP65 is reached. Otherwise the unit is not safe for use in Hazardous Locations.

The cable glands must be protected against mechanical damage.

