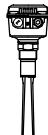

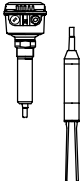

Table of content

	Page
Overview	P2
Specifications	P4
Applications	P5
<hr style="border-top: 1px dashed black;"/>	
VN ..020 Short extension length	P6
	
<hr style="border-top: 1px dashed black;"/>	
VN ..030 Pipe extension	P8
	
<hr style="border-top: 1px dashed black;"/>	
VN ..040 Pipe extension (screwed)	P10
	
<hr style="border-top: 1px dashed black;"/>	
VN ..050 Cable extension	P12
	
<hr style="border-top: 1px dashed black;"/>	
Options	P14
Accessories	P16
Dimensions	P17
Detailed Ex-markings	P20
Electrical installation	P21
Spare parts Electronic modules	P23

Subject to technical change.

Valid from 01.04.2010 until 31.03.2011 unless otherwise agreed.

All dimensions in mm (inches).

By publishing this option list all other option lists become invalid.

We assume no liability for typing errors.

Different variations to those specified are possible.
 Please contact our technical consultants.

Overview

- Level limit detection in bulk goods / solids
- Compact unit
- Die-casted housing aluminium
- Wide range of applications, no maintenance
- Full, demand, empty detector
- ATEX, FM, CSA GasEx and DustEx approvals

Series

VN 1000	VN 2000	VN 5000	VN 6000
ATEX approval Small housing Short oscillating rods Sensitivity > 50g/l (3lb/ft ³) For extreme mech. load For mounting in down pipes Advantageous design to avoid bridges Also for interface applications	ATEX approval Small housing Standard oscillating rods Sensitivity > 20 g/l (1.2lb/ft ³) Option > 5g/l (0.3lb/ft ³) Vibrasil® < 5g/l (0.3lb/ft ³)	ATEX / FM / CSA approval Spacious housing Short oscillating rods Sensitivity > 50g/l (3 lb/ft ³) For extreme mech. load For mounting in down pipes Advantageous design to avoid bridges Also for interface applications	ATEX / FM / CSA approval Spacious housing Standard oscillating rods Sensitivity > 20g/l (1.2lb/ft ³) Option > 5g/l (0.3lb/ft ³) Vibrasil® < 5g/l (0.3lb/ft ³)



VN ..020 Short extension length

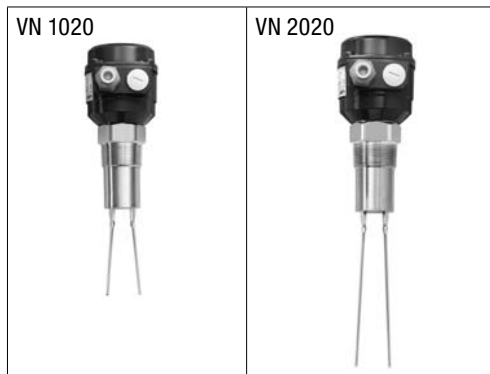

VN ..030 Pipe extension



Overview

VN ..040
 Pipe extension
 (screwed)

 Custom made
 pipe for flexible
 lengths

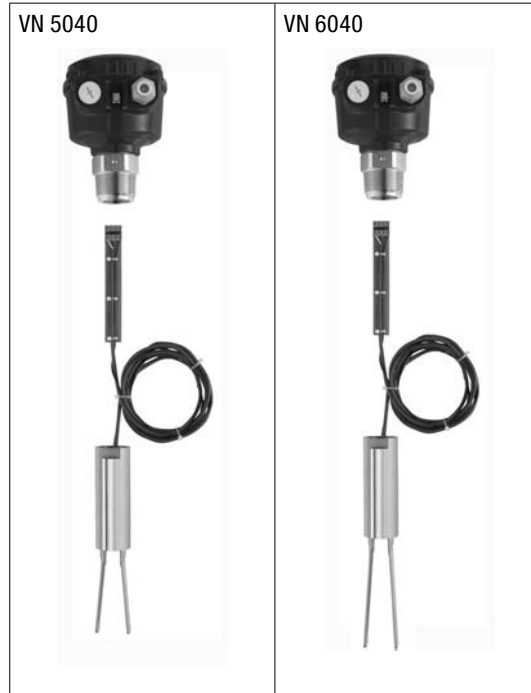
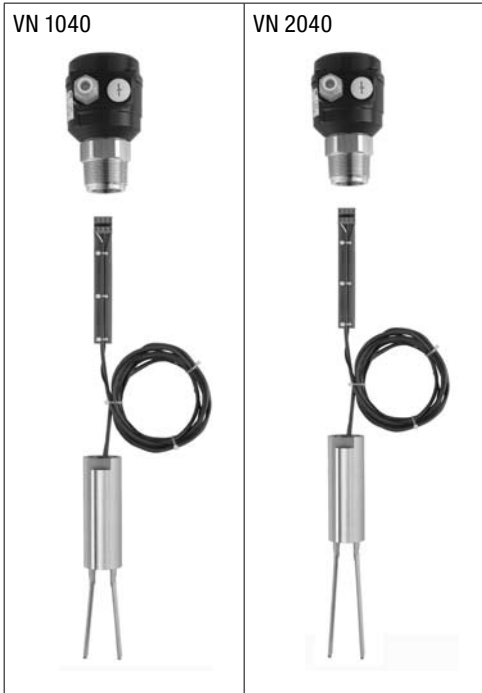

VN ..050
 Cable extension



Specifications

Series		VN 1000	VN 2000	VN 5000	VN 6000	
Approvals	CE	•	•	•	•	
	ATEX:					
	Zone 20/21	Dust Ignition Proof	•	•	•	•
	Zone 0	Intrinsic Safe	•	•	•	•
	Zone 1	Flameproof / Increased Safety			•	•
	FM / CSA:					
	General purp.				•	•
	Cl. II, III Div. 1	Dust Ignition Proof			•	•
	Cl. I Div. 1	Intrinsic Safe			•	•
	Cl. I Div. 1	Explosionproof			•	•
Zone 0	Intrinsic Safe			•	•	
Zone 1	Flameproof / Increased Safety			•	•	
Electronics	Relais SPDT	19..230V AC 19..55V DC	•	•	•	•
	Relais DPDT	19..230V AC 19..36V/55V DC	•	•	•	•
	PNP	18..50V DC	•	•	•	•
	2-wire without contact	19..230V AC/DC	•	•	•	•
	NAMUR	IEC 60947-5-6 2-wire		•		•
	8/16mA	12.5-30/36V DC 2-wire	•	•	•	•

Extensions	VN ..020	Length of extension	165mm (6.47")	235mm (9.25")	165mm (6.47")	235mm (9.25")
		Ambient temperature	-40 .. +60°C (-40 .. +140°F)			
		Process temperature	-40 .. +150°C (-40 .. +302°F)			
		Process pressure	-1 .. +10bar (-14.5 .. +145 psi)			
		Process connection material	1.4301 (SS 304) or 1.4571 (SS 316 TI)			
	VN ..030	Length of extension	300 .. 4.000mm (11.8 .. 157")			
		Ambient temperature	-40 .. +60°C (-40 .. +140°F)			
		Process temperature	-40 .. +150°C (-40 .. +302°F)			
		Process pressure	-1 .. +10bar (-14.5 .. +145 psi)			
		Process connection material	1.4301 (SS 304) or 1.4571 (SS 316 TI)			
	VN ..040	Length of extension	1.500mm (59") or 4.000mm (157")			
		Ambient temperature	-40 .. +60°C (-40 .. +140°F)			
		Process temperature	-40 .. +150°C (-40 .. +302°F)			
		Process pressure	-1 .. +10bar (-14.5 .. +145 psi)			
		Process connection material	1.4301 (SS 304) or 1.4571 (SS 316 TI)			
	VN ..050	Length of extension	750 ... 20.000mm (27.6" .. 787")			
		Ambient temperature	-25 .. +60°C (-13 .. +140°F)			
		Process temperature	-25 .. +80°C (-13 .. +176°F)			
		Process pressure	-1 .. +6bar (-14.5 .. +87 psi)			
		Process connection material	1.4301 (SS 304) Cable isolation: PUR			

Applications

Detection of solids

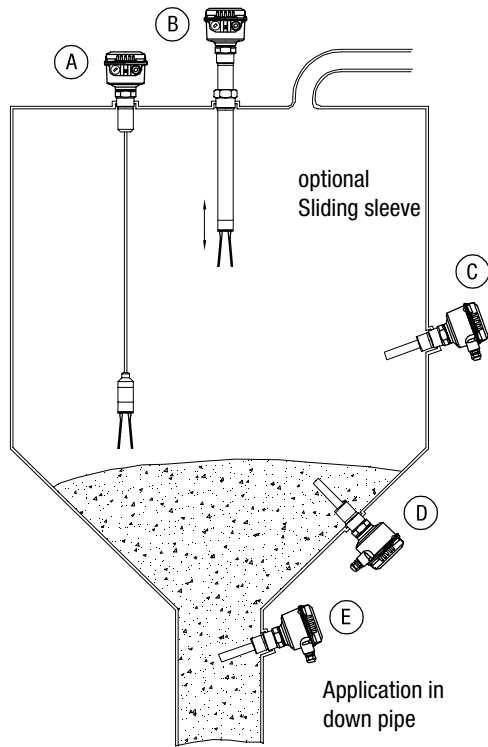

Detection of solids in water

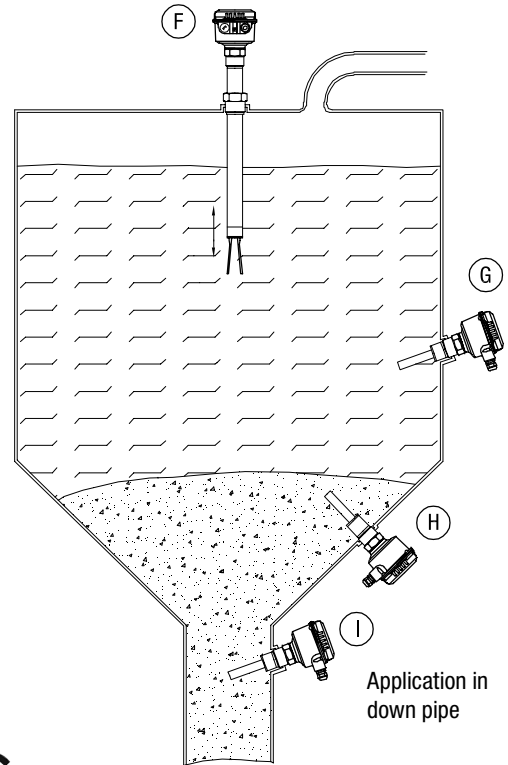

Gas and Dust
(optional)

	(A)	(B)	(C)	(D)	(E)	(F)	(G)	(H)	(I)
VN 1020			•	•	•		•	•	•
VN 1030		•	•			•	•		
VN 1040		•	•						
VN 1050	•								
VN 2020			•	•	•				
VN 2030		•	•						
VN 2040		•	•						
VN 2050	•								
VN 5020			•	•	•	•	•	•	•
VN 5030		•	•			•	•		
VN 5040		•	•						
VN 5050	•								
VN 6020			•	•	•				
VN 6030		•	•						
VN 6040		•	•						
VN 6050	•								

VN ..020 Short extension length

VN 1020



VN 2020



VN 5020



VN 6020



Housings VN 5020 / 6020



Standard

d (flameproof)

de (flameproof / increased safety)

Cable entries

Depending on model selected, the following cable entries are supported (options see pos 23 on page 14):

Version:	Cable entries:
ATEX flameproof (pos.2 T)	M20x1.5 (1x conduit + 1x Ex-d blind plug)
FM and CSA (pos.2 M,N,P,S,U)	NPT 1/2" tapered ANSI B1.20.1 (1x conduit + 1x Ex-d blind plug)
All other versions	M20x1.5 (1x screwed cable gland + 1x blind plug)

Dimensions

see pages 17-20

pos. 3
 Temperature extended shaft
 applications up to 150°C (302°F)

- 1 without
- 2 with

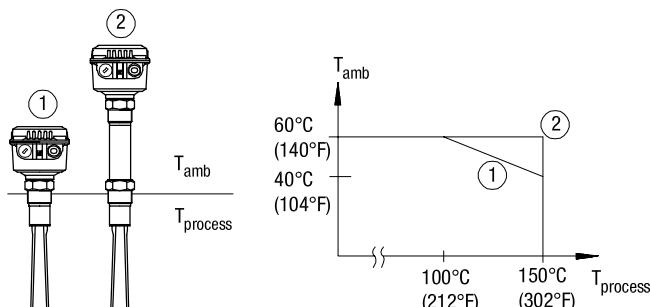

VN ..020 Short extension length

Basic type

- VN 1020
- VN 2020
- VN 5020
- VN 6020

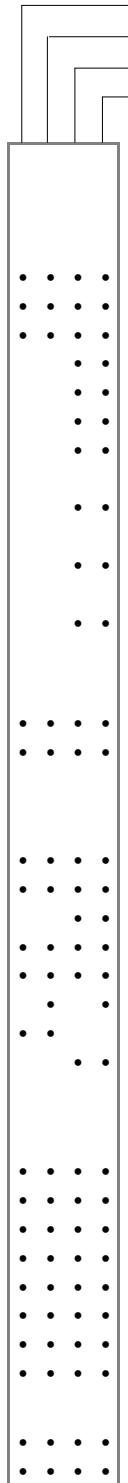

pos. 2 Certificate (detailed Ex-markings: see page 20)

Certi- ficate	Zone / Div		Protection method
	Dust	Gas	
0	CE	-	-
W	ATEX	Zone 20/21	-
Y	ATEX	Zone 20/21	Zone 0
R	ATEX	Zone 20/21	Zone 1
T	ATEX	Zone 20/21	Zone 1
M	FM / CSA	-	-
N	FM / CSA	Cl. II, III, Div.1	-
	CSA	A 20/21	-
P	FM / CSA	Cl. II, III, Div.1	Cl. I Div.1 / Zone 0
	CSA	A 20/21	-
S	FM / CSA	Cl. II, III, Div.1	Zone 1
	CSA	A 20/21	-
U	FM / CSA	Cl. II, III, Div.1	Cl. I Div.1 / Zone 1
	CSA	A 20/21	-

pos. 3 Temperature extended shaft

- 1 without (upto $T_{process} = 150^{\circ}C$ (302°F) at $T_{amb} < 40^{\circ}C$ (104°F))
- 2 with (upto $T_{process} = 150^{\circ}C$ (302°F) at $T_{amb} > 40^{\circ}C$ (104°F))

pos. 4 Electronic module

- E Relay SPDT 19..230V AC 19..55V DC
- L Relay DPDT 19..230V AC 19..55V DC
- └ 19..230V AC 19..36V DC
- D PNP 18..50V DC
- K 2-wire without contact 19..230V AC/DC
- M NAMUR IEC 60947-5-6 2-wire
- N 8/16mA or 4-20mA 12,5..36V* DC 2-wire
- N 8/16mA or 4-20mA 12,5..36V* DC 2-wire

*30V intrinsic safe

applicable for certificates (pos.2)									
O	W	Y	R	T	M	N	P	S	U
•	•	•	•	•	•	•	•	•	•
•	•		(1)	(1)	•	•	(1)	(1)	
			(2)	(2)			(2)	(2)	
•	•		•	•	•	•	•	•	•
•	•		•						

(1) with pos.3 1
 (2) with pos.3 2 or pos.26 1/2

pos. 5 Process connection

- A Thread R 1½ inch, conical DIN 2999
- B Thread NPT 1½ inch, conical ANSI B1.20.1
- P Triclamp 2" (DN 50) ISO 2852
- L Flange DN 100 PN6, EN1092-1 (max. 6 bar (87psi))
- M Flange DN 100 PN16, EN1092-1
- S Flange 2" 150lbs ANSI B16.5
- T Flange 3" 150lbs ANSI B16.5
- U Flange 4" 150lbs ANSI B16.5

pos. 8 Material of process connection / extension "L"

- 1 Stainless steel 1.4301 (304)
 - 2 Stainless steel 1.4571 (316Ti)
- Teflon coating on request

Further options and accessories: see page 14-16

Basic type

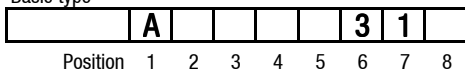

← **Order code**

Position 1 2 3 4 5 6 7 8

All positions are available with special design (use code "Z").

VN ..030 Pipe extension

VN 1030



VN 2030



VN 5030



VN 6030



Housings VN 5030 / 6030



d (flameproof)

de (flameproof /
increased safety)

Cable entries

Depending on model selected, the following cable entries are supported (options see pos 23 on page 14):

Version:	Cable entries:
ATEX flameproof (pos.2 T)	M20x1.5 (1x conduit + 1x Ex-d blind plug)
FM and CSA (pos.2 M,N,P,S,U)	NPT 1/2" tapered ANSI B1.20.1 (1x conduit + 1x Ex-d blind plug)
All other versions	M20x1.5 (1x screwed cable gland + 1x blind plug)

Dimensions

see pages 17-20

pos. 3

Temperature extended shaft
 applications up to 150°C (302°F)

- 1 without
- 2 without and with extended socket
- 3 with

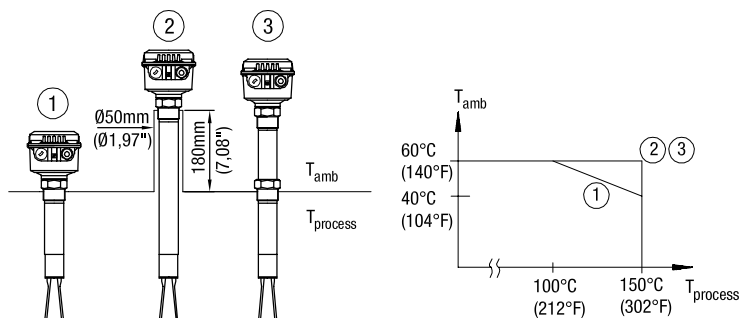

VN ..040 Pipe extension (screwed)

VN 1040



VN 2040



VN 5040



VN 6040



Housings VN 5040 / 6040



Standard



d (flameproof)



de (flameproof /
increased safety)

Cable entries

Depending on model selected, the following cable entries are supported (options see pos 23 on page 14):

Version:	Cable entries:
ATEX flameproof (pos.2 T)	M20x1.5 (1x conduit + 1x Ex-d blind plug)
FM and CSA (pos.2 M,N,P,S,U)	NPT 1/2" tapered ANSI B1.20.1 (1x conduit + 1x Ex-d blind plug)
All other versions	M20x1.5 (1x screwed cable gland + 1x blind plug)

Dimensions

see pages 17-20

applications up to 150°C (302°F)

- 1 without extended socket
- 2 with extended socket

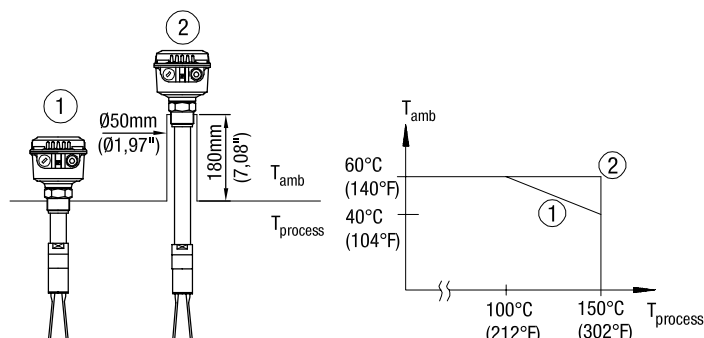

VN ..040 Pipe extension (screwed)

Basic type

- VN 1040
- VN 2040
- VN 5040
- VN 6040

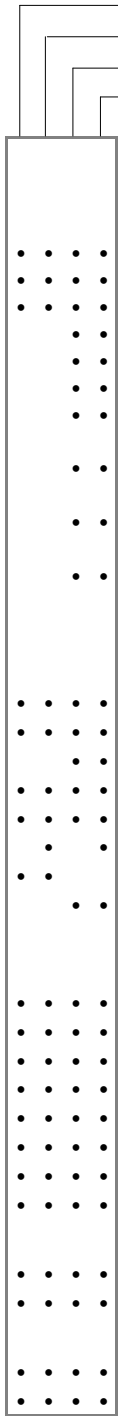

pos. 2 Certificate (detailed Ex-markings: see page 20)

Certificate	Zone / Div		Protection method
	Dust	Gas	
O CE	–	–	
W ATEX	Zone 20/21	–	Dust Ignition Proof
Y ATEX	Zone 20/21	Zone 0	Intrinsic Safe / Dust Ignition Proof
R ATEX	Zone 20/21	Zone 1	Flameproof / Increased Safety / Dust Ignition Proof
T ATEX	Zone 20/21	Zone 1	Flameproof / Dust Ignition Proof
M FM / CSA	–	–	General purpose
N FM / CSA	Cl. II, III, Div.1 A 20/21	–	Dust Ignition Proof
P FM / CSA	Cl. II, III, Div.1 A 20/21	Cl. I Div.1 / Zone 0	Intrinsic Safe / Dust Ignition Proof
S FM / CSA	Cl. II, III, Div.1 A 20/21	Zone 1	Flameproof / Increased Safety / Dust Ignition Proof
U FM / CSA	Cl. II, III, Div.1 A 20/21	Cl. I Div.1 / Zone 1	Explosion Proof / Dust Ignition Proof

pos. 4 Electronic module

- E Relay SPDT 19..230V AC 19..55V DC
- L Relay DPDT 19..230V AC 19..55V DC
- 19..230V AC 19..36V DC
- D PNP 18..50V DC
- K 2-wire without contact 19..230V AC/DC
- M NAMUR IEC 60947-5-6 2-wire
- N 8/16mA or 4-20mA 12,5..36V* DC 2-wire
- N 8/16mA or 4-20mA 12,5..36V* DC 2-wire

*30V intrinsic safe

applicable for certificates (pos.2)									
O	W	Y	R	T	M	N	P	S	U
•	•		•	•	•	•		•	•
•	•				•	•			
				•	•			•	•
•	•			•	•	•		•	•
•	•								

pos. 5 Process connection

- A Thread R 1½ inch, conical DIN 2999
- B Thread NPT 1½ inch, conical ANSI B1.20.1
- P Triclamp 2" (DN 50) ISO 2852
- L Flange DN 100 PN6, EN1092-1 (max. 6 bar (87psi))
- M Flange DN 100 PN16, EN1092-1
- S Flange 2" 150lbs ANSI B16.5
- T Flange 3" 150lbs ANSI B16.5
- U Flange 4" 150lbs ANSI B16.5

pos. 7 Length of extension "L"

- L 1.500mm (59") (cuttable cable length)
- M 4.000mm (157") (cuttable cable length)

pos. 8 Material of process connection / extension "L"

- 1 Stainless steel 1.4301 (304)
 - 2 Stainless steel 1.4571 (316TI)
- Teflon coating on request

Further options and accessories: see page 14-16

Basic type

	C	1	3					
--	----------	----------	----------	--	--	--	--	--

← Order code

Position 1 2 3 4 5 6 7 8

All positions are available with special design (use code "Z").

VN ..050 Cable extension

VN 1050



VN 2050



VN 5050



VN 6050



Housings VN 5050 / 6050



Standard



d (flameproof)



de (flameproof /
increased safety)

Cable entries

Depending on model selected, the following cable entries are supported (options see pos 23 on page 14):

Version:	Cable entries:
ATEX flameproof (pos.2 T)	M20x1.5 (1x conduit + 1x Ex-d blind plug)
FM and CSA (pos.2 M,N,P,S,U)	NPT 1/2" tapered ANSI B1.20.1 (1x conduit + 1x Ex-d blind plug)
All other versions	M20x1.5 (1x screwed cable gland + 1x blind plug)

Dimensions

see pages 17-20

Options

Short extension length				Pipe extension				Pipe extension (screwed)				Cable extension			
VN 1020	VN 2020	VN 5020	VN 6020	VN 1030	VN 2030	VN 5030	VN 6030	VN 1040	VN 2040	VN 5040	VN 6040	VN 1050	VN 2050	VN 5050	VN 6050
• • 1 1	• • 1 1	• • 1 1	• • 1 1	• • 1 1	• • 1 1	• • 1 1	• • 1 1	• • 1 1	• • 1 1	• • 1 1	• • 1 1	• • 1 1	• • 1 1	• • 1 1	• • 1 1
• • • •	• • • •	• • • •	• • • •	• • • •	• • • •	• • • •	• • • •	• • • •	• • • •	• • • •	• • • •	• • • •	• • • •	• • • •	• • • •
• • • •	• • • •	• • • •	• • • •	• • • •	• • • •	• • • •	• • • •	• • • •	• • • •	• • • •	• • • •	• • • •	• • • •	• • • •	• • • •
• • • •	• • • •	• • • •	• • • •	• • • •	• • • •	• • • •	• • • •	• • • •	• • • •	• • • •	• • • •	• • • •	• • • •	• • • •	• • • •
• • 2 2	• • 2 2	• • 2 2	• • 2 2	• • 2 2	• • 2 2	• • 2 2	• • 2 2	• • 2 2	• • 2 2	• • 2 2	• • 2 2	• • 2 2	• • 2 2	• • 2 2	• • 2 2
• • 3 3	• • 3 3	• • 3 3	• • 3 3	• • 3 3	• • 3 3	• • 3 3	• • 3 3	• • 3 3	• • 3 3	• • 3 3	• • 3 3	• • 3 3	• • 3 3	• • 3 3	• • 3 3
• • • •	• • • •	• • • •	• • • •	• • • •	• • • •	• • • •	• • • •	• • • •	• • • •	• • • •	• • • •	• • • •	• • • •	• • • •	• • • •
• • • •	• • • •	• • • •	• • • •	• • • •	• • • •	• • • •	• • • •	• • • •	• • • •	• • • •	• • • •	• • • •	• • • •	• • • •	• • • •
• •	• •	• •	• •	• •	• •	• •	• •	• •	• •	• •	• •	• •	• •	• •	• •
4 4	4 4	4 4	4 4	4 4	4 4	4 4	4 4	4 4	4 4	4 4	4 4	4 4	4 4	4 4	4 4
4 4	4 4	4 4	4 4	4 4	4 4	4 4	4 4	4 4	4 4	4 4	4 4	4 4	4 4	4 4	4 4
4 4	4 4	4 4	4 4	4 4	4 4	4 4	4 4	4 4	4 4	4 4	4 4	4 4	4 4	4 4	4 4
5 5 6 6	5 5 6 6	5 5 6 6	5 5 6 6	5 5 6 6	5 5 6 6	5 5 6 6	5 5 6 6	5 5 6 6	5 5 6 6	5 5 6 6	5 5 6 6	5 5 6 6	5 5 6 6	5 5 6 6	5 5 6 6
5 5 6 6	5 5 6 6	5 5 6 6	5 5 6 6	5 5 6 6	5 5 6 6	5 5 6 6	5 5 6 6	5 5 6 6	5 5 6 6	5 5 6 6	5 5 6 6	5 5 6 6	5 5 6 6	5 5 6 6	5 5 6 6
7 7 7 7	7 7 7 7	7 7 7 7	7 7 7 7	7 7 7 7	7 7 7 7	7 7 7 7	7 7 7 7	7 7 7 7	7 7 7 7	7 7 7 7	7 7 7 7	7 7 7 7	7 7 7 7	7 7 7 7	7 7 7 7
8 8 8 8	8 8 8 8	8 8 8 8	8 8 8 8	8 8 8 8	8 8 8 8	8 8 8 8	8 8 8 8	8 8 8 8	8 8 8 8	8 8 8 8	8 8 8 8	8 8 8 8	8 8 8 8	8 8 8 8	8 8 8 8
9 9 9 9	9 9 9 9	9 9 9 9	9 9 9 9	9 9 9 9	9 9 9 9	9 9 9 9	9 9 9 9	9 9 9 9	9 9 9 9	9 9 9 9	9 9 9 9	9 9 9 9	9 9 9 9	9 9 9 9	9 9 9 9

pos. 21	Weather-protection cover																																		
	(for Ex only approved for Zone 2 or 22 or Div. 2)																																		
	Mounting set for flange mounting																																		
	<table border="1"> <thead> <tr> <th rowspan="2">process connection flange</th> <th rowspan="2">for counter flange with</th> <th colspan="4">consists of</th> </tr> <tr> <th>screws*</th> <th>nuts*</th> <th>washers*</th> <th>sealing**</th> </tr> </thead> <tbody> <tr> <td>L</td> <td>hole ø18</td> <td>4 pcs M16x60</td> <td>4 pcs M16</td> <td>4 pcs</td> <td>1 piece</td> </tr> <tr> <td>L</td> <td>thread M16</td> <td>4 pcs M16x40</td> <td></td> <td>4 pcs</td> <td>1 piece</td> </tr> <tr> <td>M</td> <td>hole ø18</td> <td>8 pcs M16x60</td> <td>8 pcs M16</td> <td>8 pcs</td> <td>1 piece</td> </tr> <tr> <td>M</td> <td>thread M16</td> <td>8 pcs M16x40</td> <td></td> <td>8 pcs</td> <td>1 piece</td> </tr> </tbody> </table>	process connection flange	for counter flange with	consists of				screws*	nuts*	washers*	sealing**	L	hole ø18	4 pcs M16x60	4 pcs M16	4 pcs	1 piece	L	thread M16	4 pcs M16x40		4 pcs	1 piece	M	hole ø18	8 pcs M16x60	8 pcs M16	8 pcs	1 piece	M	thread M16	8 pcs M16x40		8 pcs	1 piece
process connection flange	for counter flange with			consists of																															
		screws*	nuts*	washers*	sealing**																														
L	hole ø18	4 pcs M16x60	4 pcs M16	4 pcs	1 piece																														
L	thread M16	4 pcs M16x40		4 pcs	1 piece																														
M	hole ø18	8 pcs M16x60	8 pcs M16	8 pcs	1 piece																														
M	thread M16	8 pcs M16x40		8 pcs	1 piece																														
	* material stainless steel A2 **max. 125°C (256°F)																																		
	Cable entry																																		
	Optional available:																																		
pos. 23x	M20x1,5 2x screwed cable gland																																		
pos. 23y	M20x1,5 1x screwed cable gland +1x blind plug																																		
pos. 23a	NPT 1/2" tapered ANSI B1.20.1 (1x conduit + 1x Ex-d blind plug)																																		
pos. 23b	NPT 3/4" tapered ANSI B1.20.1 (1x conduit + 1x Ex-d blind plug)																																		
	Sliding sleeve (max. 10bar (145psi), max. 150°C (302°F))																																		
	process connection as follows or flange as chosen; with Triclamp on request																																		
	Not for Ex applications Zone 0/1 (Cat. 1/2) with separation wall																																		
pos. 25w	G2" ISO 228 material 1.4301 (304)																																		
pos. 25x	G2" ISO 228 material 1.4571 (316 TI)																																		
pos. 25u	NPT 2" ANSI B1.20.1 material 1.4301 (304)																																		
pos. 25v	NPT 2" ANSI B1.20.1 material 1.4571 (316 TI)																																		
	Special versions																																		
pos. 26x	Enhanced sensitivity (> 5g/l (0,3lb/ft ³))																																		
pos. 26a	Vibrasil 70 (sensitivity <5g/l (0,3lb/ft ³))																																		
pos. 26b	Vibrasil 90 (sensitivity <5g/l (0,3lb/ft ³))																																		
pos. 26c	Adjustable sensitivity for interface applications (only with CE)																																		
pos. 26.1	Separate housing cable length 1,5m (59")																																		
pos. 26.2	Separate housing cable length 4,0m (157")																																		
	Signal lamp																																		
pos. 27a	Bulb in cable gland, 2W green																																		
pos. 27b	LED (glass window in lid)																																		
pos. 29	Plug 4-pole (incl. PE)																																		

- 1 available for all versions except explosionproof / flameproof versions (pos.2 R,T,S,U)
- 2 available for all versions except flameproof version (pos.2 T,U)
- 3 available for FM/CSA versions (pos.2 M,N,P,S) except flameproof version (pos.2 U)
- 4 available only with electronic module "Relais SPDT" (pos.4 E)
- 5 available for all versions. Electronic module "8/16mA or 4-20mA" (pos.4 N) only with CE and ATEX Zone 20/21/0 (pos.2 O, Y)
- 6 available for all versions. Electronic module "8/16mA or 4-20mA" (pos.4 N) only with CE (pos.2 O)
- 7 available for CE (pos.2 O), not in combination with weather protection cover (pos 21)
- 8 available for all versions except explosionproof / flameproof version (pos.2 R,T,S,U)
- 9 available only for CE (pos.2 O)

Options

pos. 25
Sliding sleeve

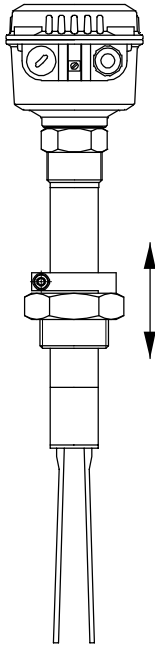

pos. 26x
Enhanced sensitivity

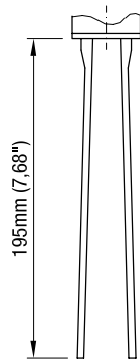

pos. 26a
Vibrasil® 70

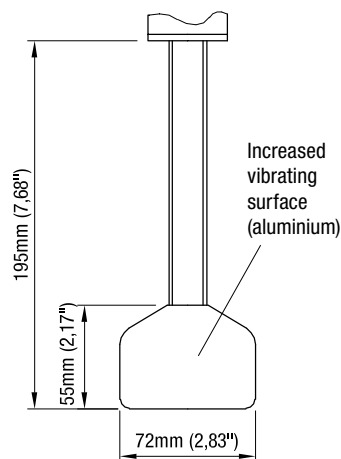

pos. 26 1-2
Seperate housing

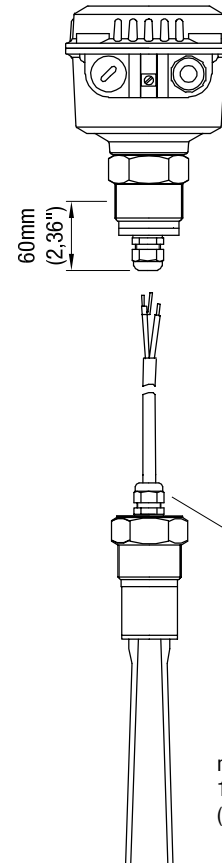

pos. 21
Weather-protection cover

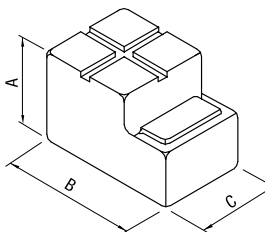

	VN 10..0 VN 20..0	VN 50..0 VN 60..0
A	100mm (3.94")	130mm (5.12")
B	165mm (6.5")	200mm (7.87")
C	88mm (3.46")	125mm (4.92")

pos. 29
Plug 4-pole

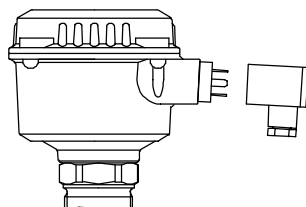

Signal lamp

pos. 27a
 Bulb in cable gland

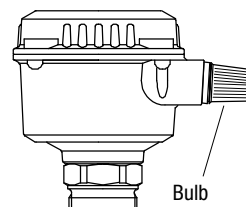

pos. 27b
 LED (glass window in lid)

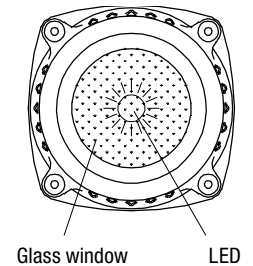

Accessories

NAMUR Isolating Switching Amplifier Protection method [Ex ia] IIC
 (for Electronic module pos.4 M)



Terminal housing. Switchable signal output logic. Each channel has one independent output.

Channels	Signal output	Monitoring*	Supply	Manufacturer / Type	Manufacturer / Type
				Pepperl & Fuchs	Turck
1	Relay (SPDT)	x	24V DC	KFD2-SR2-Ex1.W	MK13-11Ex0-R/24VDC
		x	115V AC	KFA5-SR2-Ex1.W	MK13-11Ex0-R/115VAC
		x	230V AC	KFA6-SR2-Ex1.W	MK13-11Ex0-R/230VAC
	PNP	x	24V DC	KFD2-ST2-Ex1.LB	MK13-PN-Ex0/24VDC
2	Relay (SPDT)	x	24V DC	KFD2-SR2-Ex2.W	MK13-22Ex0-R/24VDC
		x	115V AC	KFA5-SR2-Ex2.W	MK13-22Ex0-R/115VAC
		x	230V AC	KFA6-SR2-Ex2.W	MK13-22Ex0-R/230VAC
		x	24V DC	KFD2-ST2-Ex2	MK13-22P-Ex0/24VDC
	PNP	x	24V DC		MK13-22P-Ex0/24VDC
3	Relay (SPDT)	x	24V DC		MK13-33Ex0-R/24VDC
		x	115V AC		MK13-33Ex0-R/115VAC
		x	230V AC		MK13-33Ex0-R/230VAC
	PNP	x	24V DC		MK13-33Ex0-T/24VDC
4	Relay (SPDT)	x	24V DC		MK13-451Ex0-R/24VDC
		x	115V AC		MK13-451Ex0-R/115VAC
		x	230V AC		MK13-451Ex0-R/230VAC
	PNP	x	24V DC		MK13-451Ex0-T/24VDC

* Input circuit monitoring for wire-break, partial for short-circuit.
 Partial additional monitoring signal output.

Other types and manufacturers on request.

8/16mA Limit Value Monitor
 (for Electronic module pos.4 N)



Limit Value Monitor Type IM43-13-R

Input: 1 channel 4-20mA.

Output: 2 Limit Value Relays for separate output of level and diagnose.

Terminal housing. Supply: 20-250V AC/DC. Manufacturer: Turck.

Use in Hazardous Locations only with additional connected Isolating Transducer IM33.

Isolating Transducer Type IM33-11Ex-Hi/24VDC (1 channel)

Isolating Transducer Type IM33-22Ex-Hi/24VDC (2 channels)

Protection method [Ex ia] IIC.

Terminal housing.

Input/Output: 4-20mA (galvanic isolated). Supply: 19-29V DC.

Dimensions

Housing versions

Series VN 1000 / 2000

Standard

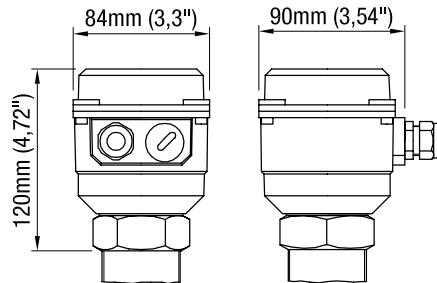

Series VN 5000 / 6000

Standard

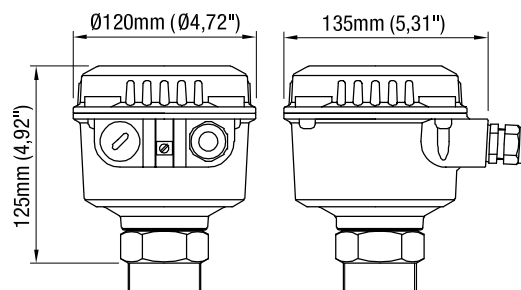

de

Explosionproof with
 increased safety
 terminal box

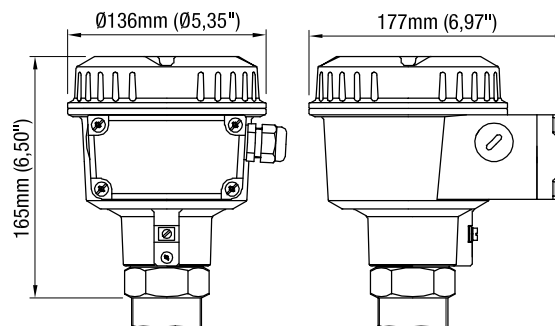

d

Flameproof /
 explosionproof

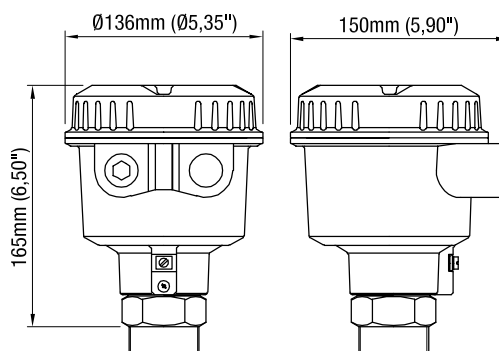

Dimensions

Extensions

VN ..020

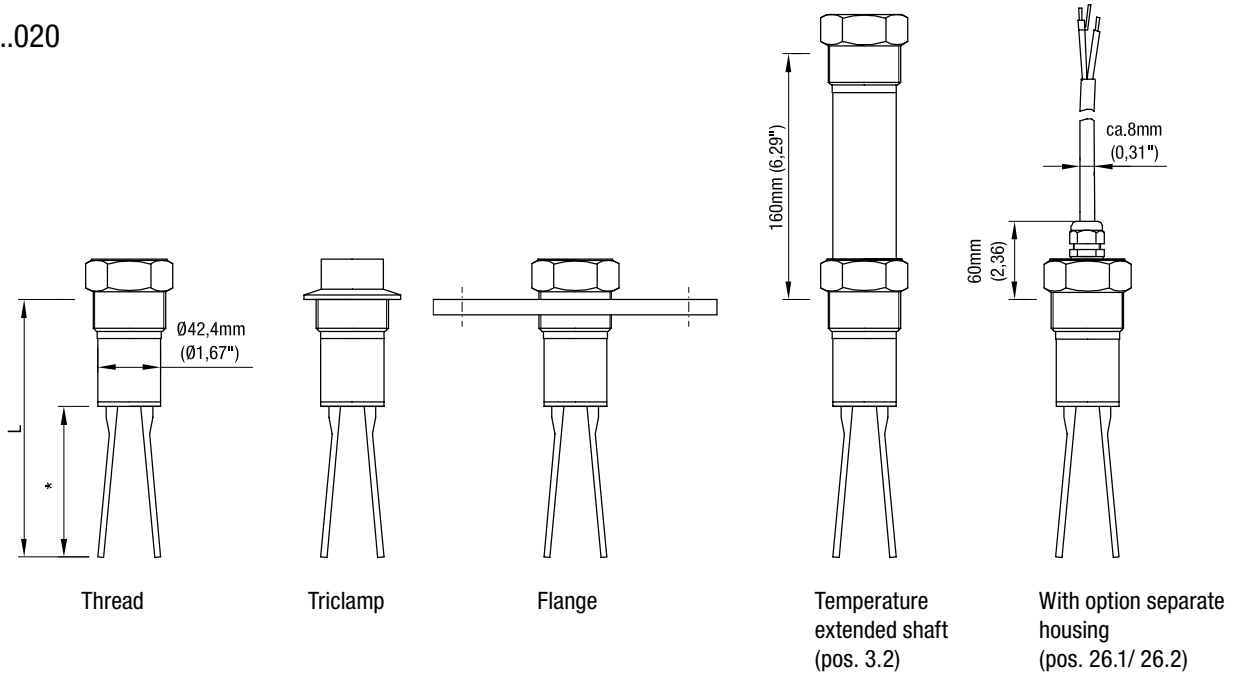

	L	
	without option	with option: Enhanced sensitivity (pos. 26x) Vibrasil® 70 (pos. 26a) Vibrasil® 90 (pos. 26b)
VN 1020 VN 5020	165mm (6.5")	
VN 2020 VN 6020	235mm (9.25")	260mm (10.24")

* see page 19 bottom right

VN ..030

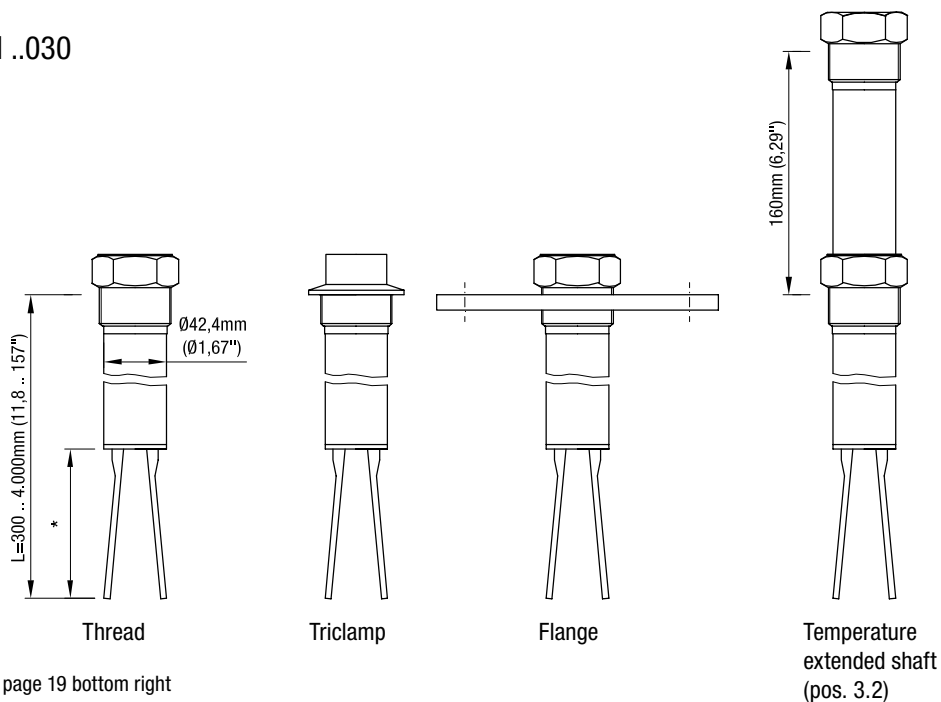

* see page 19 bottom right

Dimensions

VN ..040

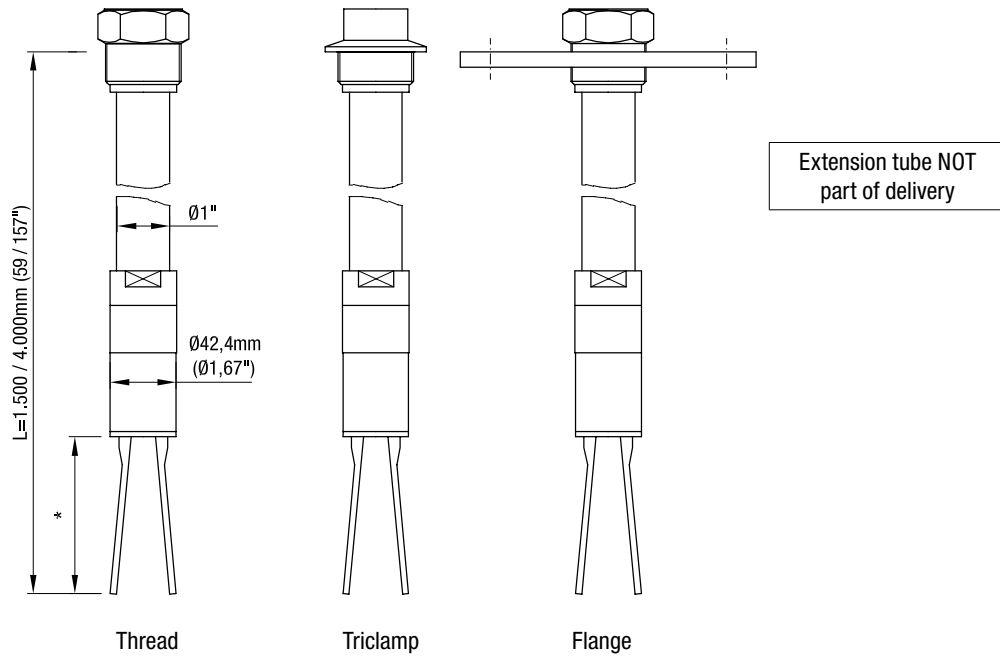

* see below right

VN ..050

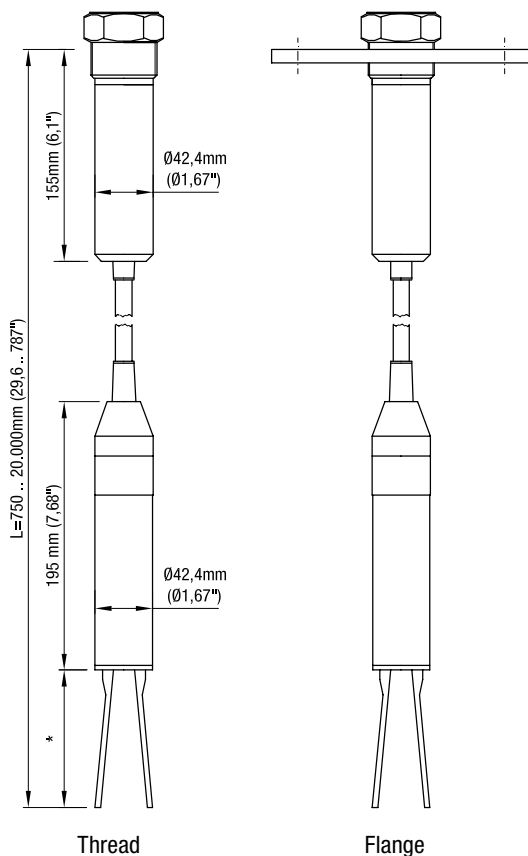

* see right

* Length of oscillating rods

VN 10..0
 VN 50..0

VN 20..0
 VN 60..0

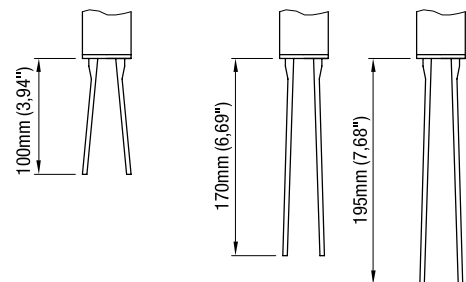

with option
 Enhanced sensitivity (pos.26x)
 Vibrasil® 70 (pos.26a)
 Vibrasil® 90 (pos.26b)

Dimensions / Detailed Ex-markings

Flanges

Code	type	number of holes	d2	Lk	D	T (thickness)
L	Flange DN100 PN6	4	18mm (0.71")	170mm (6.69")	210mm (8.27")	16mm (0.63")
M	Flange DN100 PN16	8	18mm (0.71")	180mm (7.09")	220mm (8.66")	20mm (0.79")
S	Flange 2" 150lbs	4	19.1mm (0.75")	120.7mm (4.75")	152.4mm (6.01")	19.1mm (0.75")
T	Flange 3" 150lbs	4	19.1mm (0.75")	152.4mm (6.01")	190.5mm (7.5")	23.9mm (0.94")
U	Flange 4" 150lbs	8	19.1mm (0.75")	190.5mm (7.5")	228.6mm (9")	23.9mm (0.94")

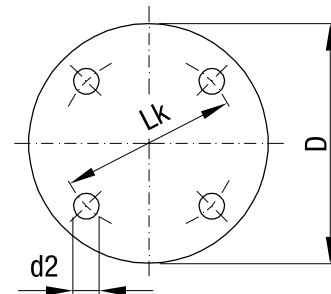

Detailed Ex-markings

pos. 2	Certificate	Housing
O	CE	Standard
W	ATEX II 1/2D	Standard
Y	ATEX II 1G and 1/2G EEx ia IIC; ATEX II 1D and 1/2D	Standard
R	ATEX II 2G EEx de [ia] IIC* and ATEX II 1/2D	de
T	ATEX II 2G EEx d [ia] IIC* and ATEX II 1/2D	d
M	FM / CSA general purpose	Standard
N	FM / CSA DIP Cl. II, III Div. 1 Gr. E,F,G CSA Ex DIP A20/21	Standard
P	FM / CSA IS Cl. I, II, III Div. 1 Gr. A-G FM Cl. I Zone 0 and 0/1 AEx ia IIC CSA Cl. I Zone 0 and 0/1 Ex ia IIC and CSA Ex DIP A20 and A20/21	Standard
S	FM Cl. I Zone 1 AEx de [ia] IIC* and FM / CSA Cl. II, III Div. 1 Gr. E,F,G CSA Cl. I Zone 1 Ex de [ia] IIC* and CSA Ex DIP A20/21	de
U	FM XP-IS Cl. I, II, III Div. 1 Gr. B-G* and FM Cl. I Zone 1 AEx d [ia] IIC* CSA XP-IS Cl. I, II, III Div. 1 Gr. B-G* CSA Cl. I Zone 1 Ex d [ia] IIC* and CSA Ex DIP A20/21	d

* [ia] or IS is not applicable for versions VN ..020 without temperature extended shaft (pos. 3.1)
 (In this case no intrinsic safe connection between Electronic module and Vibrating fork is used)

Electrical installation

Universal voltage

Relay SPDT

Power supply:

19..230V 50-60Hz +10% 8VA
 19..55V DC +10% 1,5W

Signal output:

Floating relay SPDT

VN 1000/ 2000:

AC max. 253V, 4A, 500VA at $\cos \Phi = 1$
 DC max. 253V, 4A, 60W

VN 5000/ 6000:

AC max. 250V, 8A, non inductive
 DC max. 30V, 5A, non inductive

Fuse on signal output: max 10A

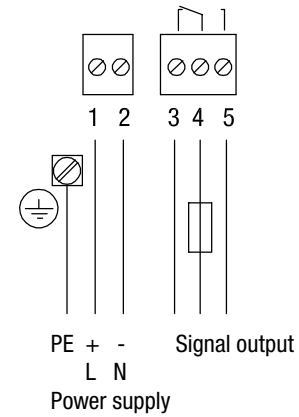

Universal voltage

Relay DPDT

Power supply::

19..230V 50-60Hz +10% 18VA
 19..55V (36V*) DC +10% 2W

Signal output:

Floating relay DPDT

VN 1000/ 2000:

AC max. 253V, 4A, 500VA at $\cos \Phi = 1$
 DC max. 253V, 4A, 60W

VN 5000/ 6000:

AC max. 250V, 8A, non inductive
 DC max. 30V, 5A, non inductive

Fuse on signal output: max 10A

* Version with intrinsic safe connection
 between electronic module and vibration fork
 (see pos.4 in pricelist)

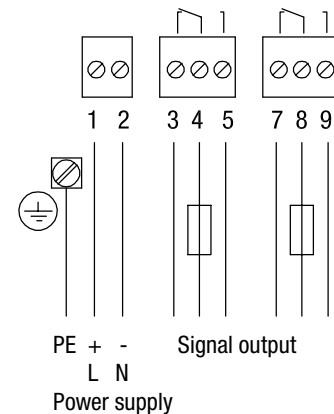

3-wire

PNP

Power supply:

18 .. 50V DC +10% 1,5W

Fuse: max 4A

Signal output:

max. 0,4A

Load for example:

PLC, relay, contactor, bulb

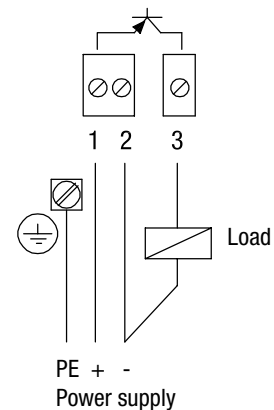

Electrical installation

2-wire

without contact

Power supply:

19..230V 50/60Hz +10% 1,5VA
 19..230V DC +10% 1W

Load:

max. 0,5A permanent
 (detailed ratings see
 "Technical data")

Load for example:
 relay, contactor, bulb

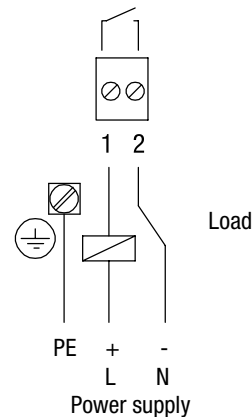

NAMUR IEC 60947-5-6

Power supply:

ca. 7..9 V DC
 intrinsic safe
 (spec. IEC 60947-5-6)

<1mA or > 2,2mA
 (spec. IEC 60947-5-6)

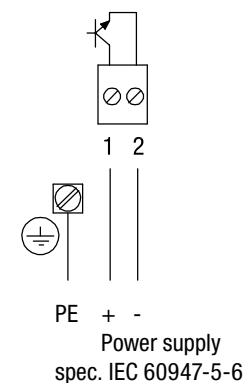

8/16mA or 4-20mA

Power supply:

Non intrinsic safe version:
 12,5..36V DC +0%

Intrinsic safe version:
 12,5..30V DC +0%

Signal output

Setting 8/16mA:
 8mA or 16mA

Setting 4-20mA:
 Output current depends on the vibration
 amplitude of the fork: 6mA for dampened
 vibration and 20mA for full vibration.

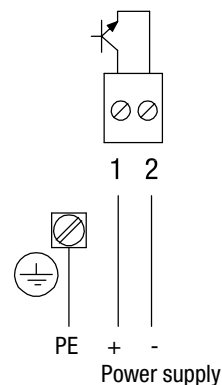

8/16mA

Power supply:

12,5..36V DC +0%

Signal output

8mA or 16mA

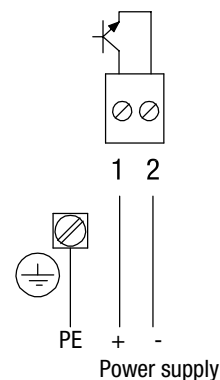

Spare parts

Electronic modules VN 1000 / VN 5000

VN 5020	VN 5020 temp. extended shaft	VN 5020 separate housing	VN 5030 VN 5040	VN 5050
Electronic modules are used for following certificates (see pos. 2 of pricelist):				
O, M, W, N, R, S, T, U	O, M, W, N	O, M	O, M, W, N	O, M
	R, S, T, U	W, N, R, S, T, U	R, S, T, U	W, N, R, S, T, U
O, M, W, N, R, S, T, U	O, M, W, N	O, M	O, M, W, N	O, M
	R, S, T, U	W, N, R, S, T, U	R, S, T, U	W, N, R, S, T, U
O, M, W, N, R, S, T, U	O, M, W, N	O, M	O, M, W, N	O, M
	R, S, T, U	W, N, R, S, T, U	R, S, T, U	W, N, R, S, T, U
O, M, W	O, M	O, M	O, M	O, M
O, M, W	O, M, W	O, M	O, M, W	O, M
O, M, W	O, M, W	O, M	O, M, W	O, M
Y	Y	Y	Y	Y

VN 1020	VN 1020 separate housing	VN 1030 VN 1040	VN 1050
Electronic modules are used for following certificates (see pos. 2 of pricelist):			
0, W	0	0, W	0
	W		W
0, W	0	0, W	0
0, W	0	0, W	0
	W		W
0, W	0	0, W	0
0, W	0	0, W	0
	W		W
0, W	0	0, W	0
Y	Y	Y	Y

Electronic module	Electronic module number
Relay (SPDT) 19..230V AC 19..55V DC	pl100932
	pl100120 *
Relay (DPDT) 19..230V AC 19..55V DC	pl100247
	pl100052 *
PNP 18..50V DC	pl100246
	pl100123 *
2-wire without contact 19..230V AC/DC	pl100242
	pl100122
8/16mA or 4-20mA 2-wire	pl100122 *
	pl100093
8/16mA or 4-20mA 2-wire intrinsic safe	pl100090 **

* Intrinsic safe connection between Electronic module and Vibrating fork

** Intrinsic safe from supply and intrinsic safe between Electronic module and Vibrating fork

Spare parts

Electronic modules VN 2000 / VN 6000

Electronic module	Sensitivity (see pos. 26)	Electronic module number	VN 2020	VN 2020 separate housing	VN 2030 VN2040	VN 2050	VN 6020	VN 6020 temp. extended shaft	VN 6020 separate housing	VN 6030 VN 6040	VN 6050
Relay (SPDT) 19..230V AC 19..55V DC	20g/l (1..2lb/ft ³)	pi100930	0, W	0	0, W	0	O, M, W, N, R, S, T, U	O, M, W, N	O, M	O, M, W, N	O, M
	5g/l (0.3lb/ft ³)	pi100931	0, W	0	0, W	0	O, M, W, N, R, S, T, U	O, M, W, N	O, M	O, M, W, N	O, M
	Vibrasil® 70	pi100312	0, W	0	0, W	0	O, M, W, N, R, S, T, U		W, N, R, S, T, U	R, S, T, U	W, N, R, S, T, U
	Vibrasil® 90	pi100310	0, W	0	0, W	0	O, M, W, N, R, S, T, U		0, M	O, M, W, N	O, M
	20g/l (1..2lb/ft ³) *	pi100124 *	0, W	W		W		R, S, T, U	W, N, R, S, T, U	R, S, T, U	W, N, R, S, T, U
	5g/l (0.3lb/ft ³) *	pi100128 *	0, W	0	0, W	0		R, S, T, U	0, M	O, M, W, N	O, M
Relay (DPDT) 19..230V AC 19..55V DC	20g/l (1..2lb/ft ³)	pi100193	0, W	0	0, W	0	O, M, W, N, R, S, T, U	O, M, W, N	0, M	O, M, W, N	O, M
	5g/l (0.3lb/ft ³)	pi100194	0, W	0	0, W	0	O, M, W, N, R, S, T, U	O, M, W, N	0, M	O, M, W, N	O, M
	20g/l (1..2lb/ft ³) *	pi100050 *	0, W	0	0, W	0	R, S, T, U	R, S, T, U	W, N, R, S, T, U	R, S, T, U	W, N, R, S, T, U
	5g/l (0.3lb/ft ³) *	pi100051 *	0, W	0	0, W	0	O, M, W, N, R, S, T, U	O, M, W, N	0, M	O, M, W, N	O, M
PNP 18..50V DC	20g/l (1..2lb/ft ³)	pi100176	0, W	0	0, W	0	O, M, W, N, R, S, T, U	O, M, W, N	0, M	O, M, W, N	O, M
	5g/l (0.3lb/ft ³)	pi100173	0, W	0	0, W	0	O, M, W, N, R, S, T, U	O, M, W, N	0, M	O, M, W, N	O, M
2-wire without contact 19..230V AC/DC	20g/l (1..2lb/ft ³)	pi100127 *	0, W	W		W		R, S, T, U	W, N, R, S, T, U	R, S, T, U	W, N, R, S, T, U
	5g/l (0.3lb/ft ³)	pi100131 *	0, W	0	0, W	0		R, S, T, U	0, M	O, M, W, N	O, M
	20g/l (1..2lb/ft ³)	pi100182	0, W	0	0, W	0					
	5g/l (0.3lb/ft ³)	pi100187	0, W	0	0, W	0					
	20g/l (1..2lb/ft ³)	pi100126	0, W	0	0, W	0					
	5g/l (0.3lb/ft ³)	pi100130	0, W	0	0, W	0					
NAMUR IEC 60947-5-6 2-wire intrinsic safe	20g/l (1..2lb/ft ³)	pi100126 *	0, W	0	0, W	0					
	5g/l (0.3lb/ft ³)	pi100130 *	0, W	0	0, W	0					
8/16mA or 4-20mA 2-wire	20g/l (1..2lb/ft ³)	pi100081 **	Y	Y	Y	Y	Y, P	Y, P	Y, P	Y, P	Y, P
	5g/l (0.3lb/ft ³)	pi100082 **	0, W	0	0, W	0	0, M, W, N, R, S, T, U	0, M, W, N	0, M	0, M, W, N	0, M
8/16mA or 4-20mA 2-wire intrinsic safe	20g/l (1..2lb/ft ³)	pi100094	0, W	0	0, W	0					
	5g/l (0.3lb/ft ³)	pi100098	0, W	0	0, W	0					
8/16mA or 4-20mA 2-wire intrinsic safe	20g/l (1..2lb/ft ³)	pi100091 **	Y	Y	Y	Y	Y, P	Y, P	Y, P	Y, P	Y, P
	5g/l (0.3lb/ft ³)	pi100092 **	0, W	0	0, W	0	0, M, W, N, R, S, T, U	0, M, W, N	0, M	0, M, W, N	0, M

* Intrinsic safe connection between Electronic module and Vibrating fork

** Intrinsic safe from supply and intrinsic safe between Electronic module and Vibrating fork