

Table of contents

	Page
Safety notes / Technical support	G2

Introduction	G3

Technical data	G4

Approvals	G6

Options	G7

Mounting	G8

Electrical installation	G11

Signal output	G14

Sensitivity / Maintenance	G15

Notes for use in Hazardous Locations	G16

Subject to technical change.
All dimensions in mm (inch).

We assume no liability for typing errors.
Different variations than specified are possible.
Please contact our technical consultants.

Safety notes / Technical support

Notes

- Installation, maintenance and commissioning may be accomplished only by qualified technical personnel.
- The product must be used only in the manner outlined in this instruction manual.

Special attention must be paid to warnings and notes as follows:

WARNING



Relates to a caution symbol on the product: A failure to observe the necessary precautions can result in death, serious injury and/or considerable material damage.

WARNING





A failure to observe the necessary precautions can result in death, serious injury and/or considerable material damage.

This symbol is used, when there is no corresponding caution symbol on the product.

CAUTION

A failure to observe the necessary precautions can result in considerable material damage.

Safety symbols

In manual and on product	Description
	CAUTION: refer to accompanying documents (manual) for details.
	Earth (ground) Terminal
	Protective Conductor Terminal

Technical support

Please contact your local supplier (for address see www.uwt.de). Otherwise you can contact:

UWT GmbH
 Westendstr. 5
 D-87488 Betzigau

Tel.: 0049 (0)831 57123-0
 Fax: 0049 (0)831 76879
info@uwt.de
www.uwt.de

Introduction

Applications

The device is used for level monitoring in all types of containers and silos.

It can be used with all powdery and granulated bulk materials with a density greater than 60 g/l (3.8lb/ft³) that do not show a strong propensity to form crusts or deposits.

The units can be delivered with Ex-approvals for use in Dust Hazardous Areas.

A selection of fields of application:



- **Building materials industry**
lime, moulding sand, etc.
- **Food industry**
milk powder, flour, salt, etc.
- **Plastics industry**
plastics granules etc.
- **Timber industry**
- **Chemical industry**
- **Mechanical engineering**

The VIBRANIVO oscillating probe is normally screwed into the lateral container wall so that it is level with the filling height to be registered and monitored.

The device can also be mounted from the top of the container. In this case an extension piece is used to mount the probe level with the height to be registered.

The length of the probe can be up to 4m (157") with an extension tube (VN 4030) .

The use of a sliding sleeve is recommended so that the switch point can be changed continuously during operation of the device.

Function

The piezo-electrically stimulated oscillating fork vibrates at its mechanical resonance frequency. If the probe is covered by the bulk material, the damping thus generated is registered electronically and a corresponding signal output is actuated. The oscillation of the fork ensures a certain self-cleaning effect..

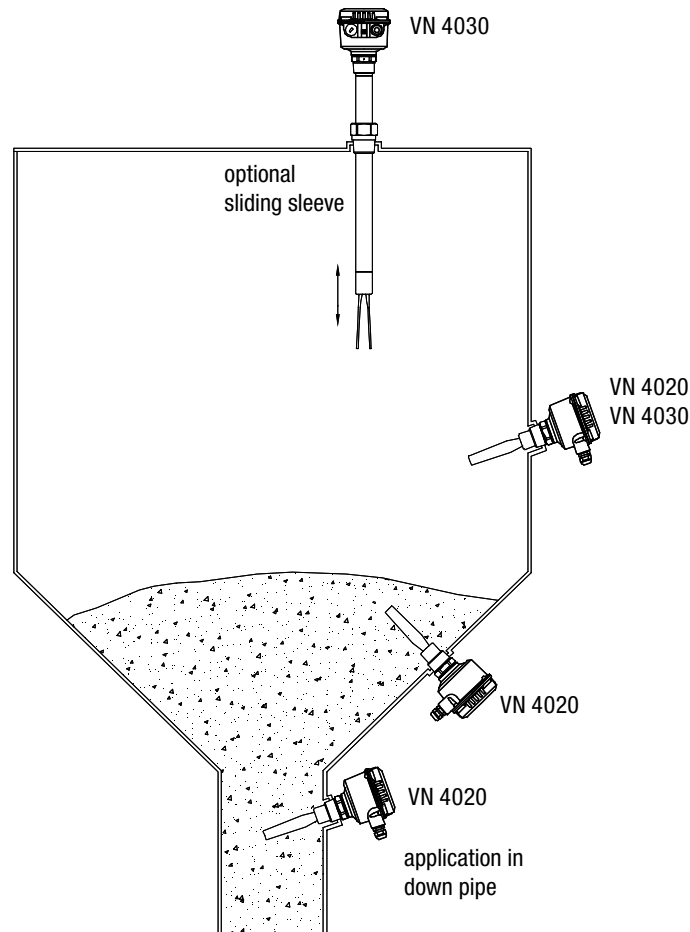

Technical data

Housing

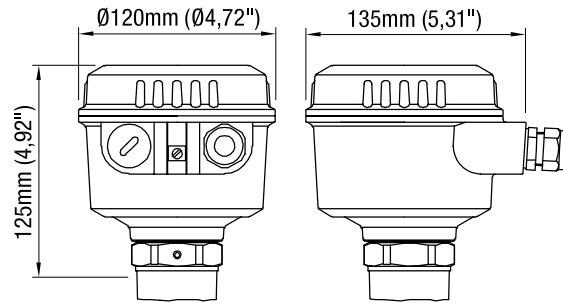

Extensions

VN 4020

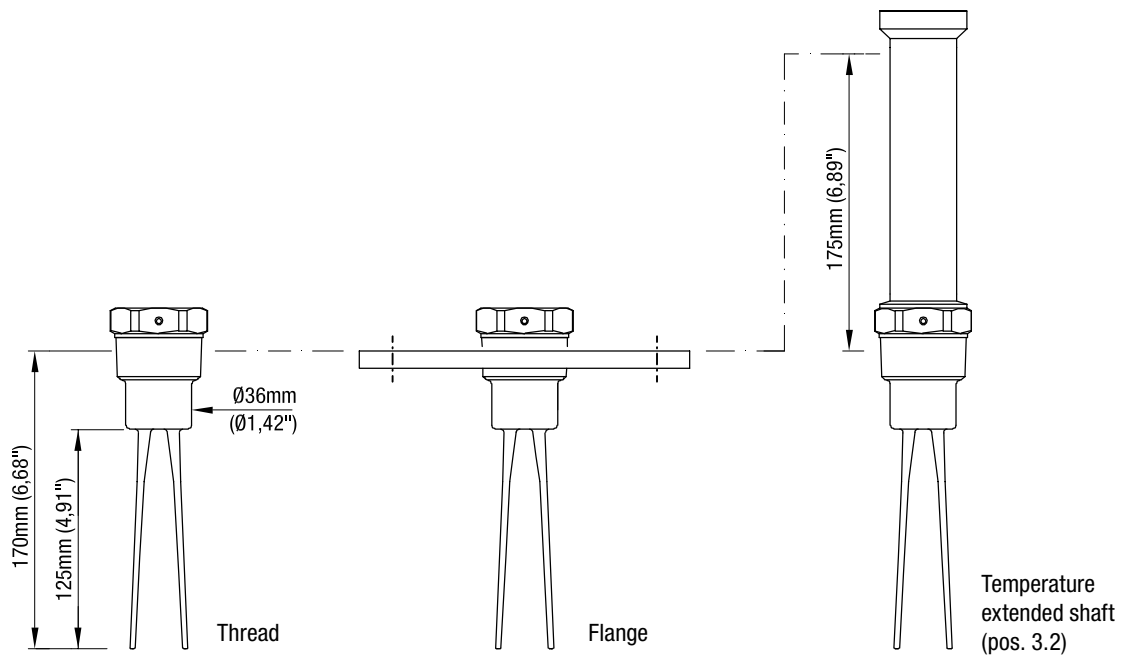

VN 4030

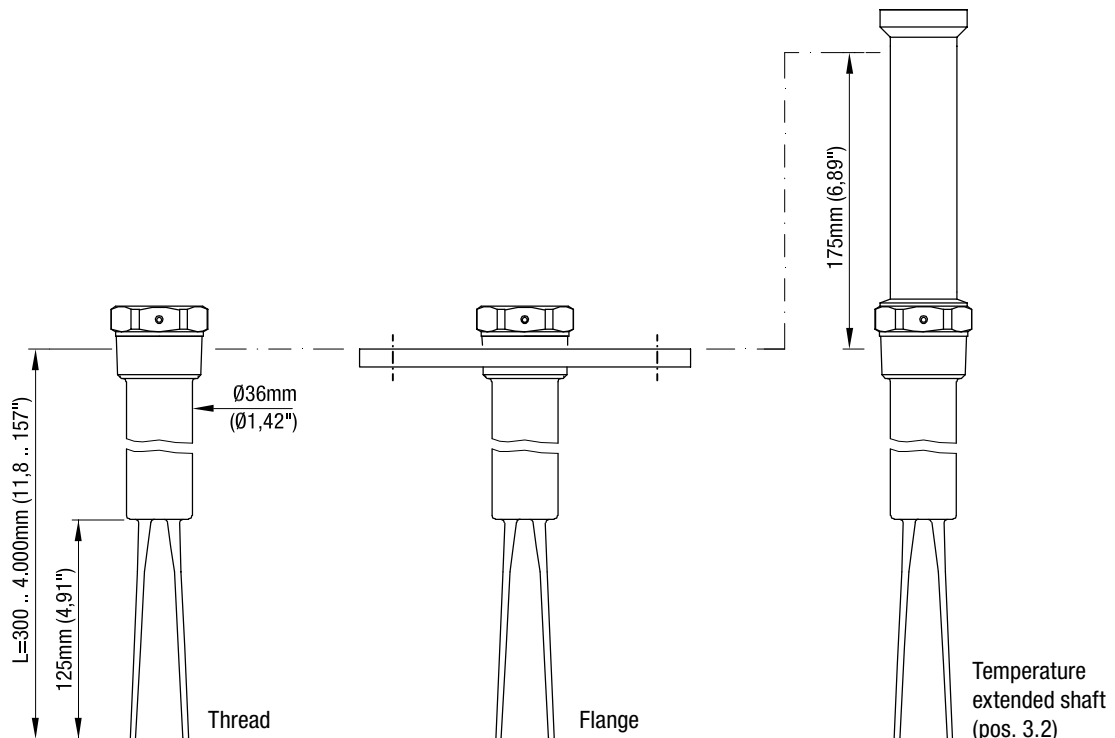

Technical data

Electrical data

Connection terminals	0.14 - 2.5mm ² (AWG 26-14)
Cable entry	M20 x 1.5 screwed cable gland NPT 1/2" conduit connection NPT 3/4" conduit connection
Signal delay	Sensor free -> covered ca. 1 sec Sensor covered -> free ca. 1..2 sec
Safety operation (FSL,FSH)	Switchable for minimum or maximum safety
Vibration frequency	ca. 200 Hz
Installation category	III
Pollution degree	2

Electronics

	Universal voltage Relay DPDT	3-wire PNP
Power supply	19..230V 50-60Hz +10% 19..50V DC +10%	18V – 50V DC +10%
Max. ripple of power supply	7 V _{ss} at DC	7 V _{ss}
Installed load	max. 18VA / 2W	max. 0.6W
Signal output	Floating relay DPDT AC max. 250V, 8A non inductive DC max. 30V, 5A non inductive	Open Collector: permanent load max. 0.4A short-circuit and overload protected turn-on voltage: max. 50V (reverse protection)
Indicating light	Status of signal output by built-in LED	Status of signal output by built-in LED
Isolation	Power supply to signal output: 2225Vrms Signal output to signal output: 2225Vrms	-
Protection class	I	III

Mechanical data

Housing	Aluminium housing, powder coated RAL 5010 gentian blue
Degree of protection	IP 66 (EN 60529), NEMA 4X, Type 4X
Process connection	Material: VN 4020: stainless steel 1.4581 (316) VN 4030: stainless steel 1.4301 (304) or 1.4571 (316TI) (Process connection and tube-extension) Thread: R 1½" tapered DIN 2999 or NPT 1½" or NPT 1¼" tapered ANSI B 1.20.1 Flanges according to selection
Oscillator	Material: stainless steel 1.4581 (316)
Overall weight (ca.)	VN 4020: 1.7kg (3.7lbs) VN 4030: 1.7kg (3.7lbs) +1.9kg/m (+4.2lbs per 39.3") extension

Technical data / Approvals

Operating conditions

Ambient temp. (housing) -40°C.. +60°C (-40 .. +140°F)

Process temperature -40°C.. +150°C (-40 .. +302°F)

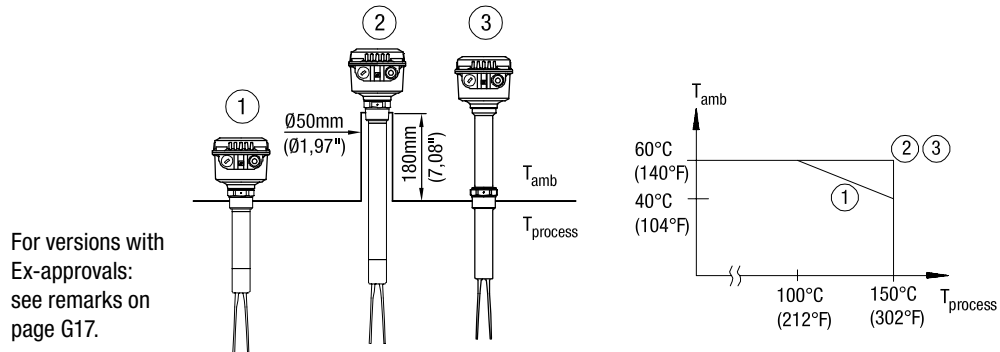

Min. powder density	Setting A ca. 150 g/l (9.5lb/ft ³)	Setting B ca. 60 g/l (3.8lb/ft ³)
Features of bulk material	No strong propensity to cake or deposit Max. grain size 8mm (0.31")	
Max. mechanical load	500N laterally (on oscillator rods) Recommended protection in case of high material load: mounting of a protective angle above the probe	
Max. mechanical torque	250 Nm (VN 4030)	
Max. process pressure	10bar (145psi) For versions with "sliding sleeve without process overpressure" (option pos 25 a, b): unpressurized For versions with Ex-approvals: see remarks on page G16.	
Relative Humidity	0-100%, suitable for outdoor use	
Altitude	max. 2.000m (6.562ft)	

Approvals

General Purpose (Ordinary Locations)	CE FM Depending on selected version in pricelist. CSA	EN 61010-1 (IEC/CB)	
Hazardous Locations	ATEX FM Depending on selected version in pricelist. CSA	Dust explosion Dust explosion Dust explosion	ATEX II 1/2 D Ex tD A20/21 Cl. II, III Div. 1 Gr. E,F,G Cl. II, III Div. 1 Gr. E,F,G Ex DIP A20/21
	Detailed allocation of types and electronics to approvals: see pricelist.		
EMC	EN 61326 -A1		

Pressure Equipment Directive (97/23/EC) The units are not subject to this directive, because they are classified as „pressure-keeping equipment“ and do not have a pressurized housing (see Art.1, Abs. 2.1.4).
 The units are designed and manufactured in accordance to the Pressure Equipment Directive.
 The unit is NOT intended for use as an "equipment part with safety function" (Art.1, Abs. 2.1.3).
 If the units should be used as „equipment part with safety function" please contact the manufacturer.

Options

Weather-protection-cover

When the measuring device is used outdoor, the use of the weather-protection-cover is recommended. It protects the device from all atmospheric influences such as:

- rain water
- condensation of water
- excessively high temperatures due to insulation
- excessively low temperatures in winter

Material: PE, weathering and temperature stable

Not available for housing version d and de.



For use in Hazardous Locations: only permitted for Category 3 (zone 2 and 22) or Division 2.

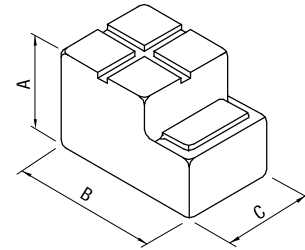

A	130mm (5.12")
B	200mm (7.87")
C	125mm (4.92")

Sliding sleeve

VN 4030 G1½" ISO 228 or
 1½" NPT ANSI B 1.20.1
 Material: 1.4301 (304) or 1.4571 (316Ti)
 Sealing material to the extension tube: viton or NBR

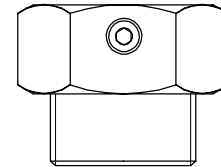

Mounting set

Screws and washers for fixing the unit on a flange.

Glass window in lid

To see the indicating light on the electronic from outside.

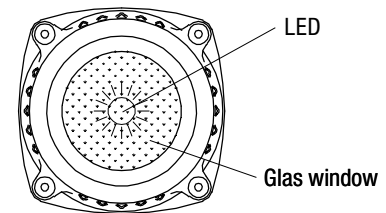

Bulb in cable gland

Bright indicating light seen from outside.

Not available for use in Hazardous Locations and FM/CSA general purpose.

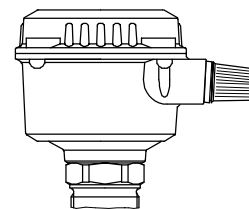

Plug 4-pole (incl. PE)

Used instead of cable gland.

Not available for use in Hazardous Locations and FM/CSA general purpose.

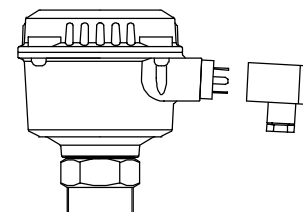

Mounting

General Safety Instructions

Process pressure ! Improper installation may result in loss of process pressure.

Chemical resistance against the medium ! Materials of construction are chosen based on their chemical compatibility (or inertness) for general purposes. For exposure to specific environments, check with chemical compatibility charts before installing.

Temperature range ! The range of the ambient and process temperature of the device must be observed (see page G6 and for Ex-approvals page G17)

Mechanical load ! The torque at the fastening spot must not exceed 300Nm (VN 4030).

Maximum length „L“ in dependence on the deviation (in degrees) from vertical installation:

Max. deviation	Max. length „L“
5°	4000 mm (157.5“)
45°	1200 mm (47.24“)
>45°	600 mm (23.62“)

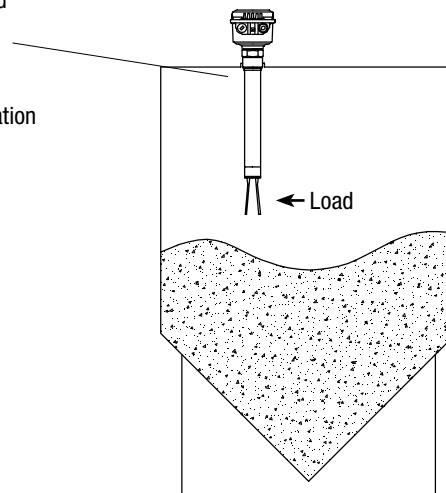

Mounting location Keep distance to incoming material and to the silo wall. The installation has to be done in a way, that the sensor elements cannot hit the wall of the silo. The flow of the medium and fixtures in the container must be considered. This is especially important for extension length more than 3m (118.1“).

Sliding sleeve “Pressure tight” version (pos. 25 e, f): Tighten both straining screws M8 with 20 Nm to obtain resistance against pressure.

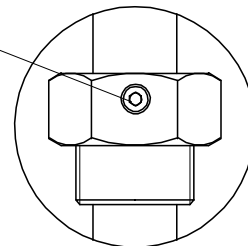

Flange mounting A plastic sealing must be used to tighten the flange.

Fastening of the threaded process connection Mounting torque for the thread may not exceed 80Nm. Use a 50mm (1.97“), for units with sliding sleeve use a 55mm (2.17“), open-end wrench. Do not fasten by turning the housing .

Mounting

! Additional Safety Instructions for Hazardous Locations

Installation regulations For devices to use in hazardous locations the respectively valid installation regulations must be observed.

ATEX: The requirements of the EN 50281-1-2 (e.g. regarding dust deposits and temperatures) must be observed.

Sparks The installation has to be done in a way mechanical friction or impact can not cause sparks between the aluminium enclosure and steel.

Mounting instructions

Oscillating rods Do not bend, shorten or extend the oscillating rods since this will destroy the device.

Rotatable housing and orientation marking of oscillating rods The housing can be rotated against the threaded connection after mounting.

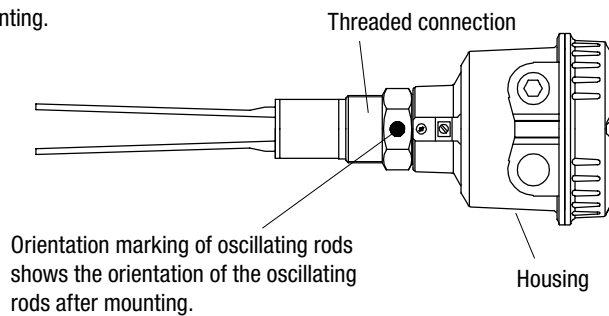

Direction of the cable glands When the unit is mounted from the side, ensure, that the cable glands faces downwards and are closed to avoid water penetration into the housing.

Sealing Seal the process thread with Teflon tape in case of process pressure

Switching point Heavy bulk material -> the signal output switches when the oscillating rods are covered a few mm
 Light bulk material -> the signal output switches, when the oscillating rods are covered a few cm

Mounting

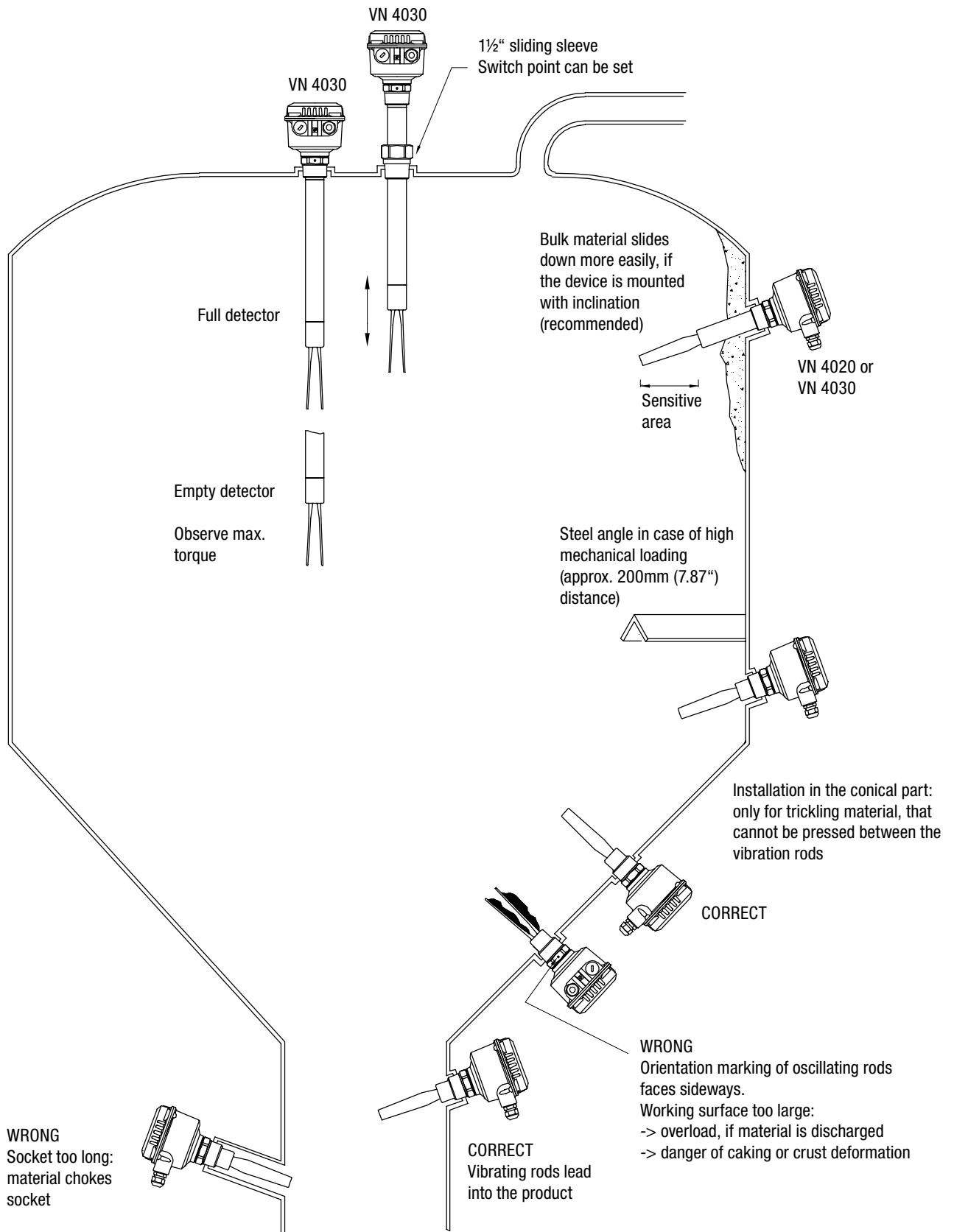

Electrical installation

General Safety Instructions

Handling	 In the case of inexpert handling or handling malpractice the electric safety of the device cannot be guaranteed.
Protective earthing	Before any electrical installation, the device must be connected to the protective earthing terminal inside the housing.
Installation regulations	The local regulations or VDE 0100 (Regulations of German Electro technical Engineers) must be observed.
Fuse	Use a fuse as stated in the connection diagrams (page G13).
RCCB protection	In the case of a defect, the distribution voltage must automatically be cut off by a RCCB protection switch so as to protect the user of the device from indirect contact with dangerous electric tensions.
Power supply switch	A Power-supply-disconnecting switch must be provided and marked near the device.
Wiring diagram	The electrical connections have to be made according to the wiring diagram.
Supply voltage	Compare the supply voltage applied with the specifications given on the electronic and name plate before switching the device on.
Cable gland	The cable gland shall reach ingress protection IP66 and has to provide a pull relief. Make sure that the screwed cable gland safely seals the cable and that it is tight (danger of water intrusion). Cable glands that are not used have to be locked with a closing element.
Conduit system	In case of using a conduit system (with NPT thread) instead of a cable gland the regulations of the country where the unit is installed must be observed. The conduit must have a tapered thread either NPT 1/2" or NPT 3/4" in accordance with the unit and ANSI B 1.20.1. Not used inlets must be closed tight with a metal closing element.
Field wiring cables	The diameter of the field wiring cable has to match to the clamping range of the used cable gland. All field wirings must have insulation suitable for at least 250V AC. The temperature rating must be at least 90°C (194°F).
Connecting the terminals	Make sure that max. 8mm (0.31") of the pigtailed are bared (danger of contact with live parts).
Relay and transistor protection	Provide protection for relay contacts and output transistors to protect the device against spikes with inductive loads.
Protection against static charging	The housing of the unit must be grounded in any case to avoid static charging of the unit on applications with pneumatic conveying and non-metallic containers .

Electrical installation

! Additional Safety Instructions for Hazardous Locations

External equipotential bonding terminal

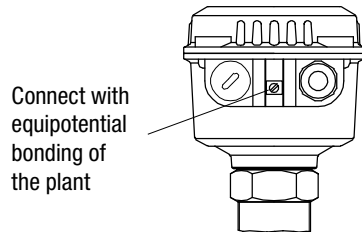

Field wiring

A pull relief must be provided for the field wiring cables, when the device is installed with the factory provided cable glands.

Cable glands for ATEX

The used entry devices and blanking elements must have an adequate type approval (EEx-“e” or EEx-“d” or EEx-“D”) and a temperature range of at least -40°C (-40°F) to $+80^{\circ}\text{C}$ (176°F). In addition they shall be suitable for the conditions and correctly installed. Where applicable the provided original parts of the manufacturer must be used.

Conduit system for ATEX

In addition the regulations of the country must be observed. The used flameproof seals and blanking elements must have an adequate type approval and a temperature range of at least -40°C (-40°F) to $+80^{\circ}\text{C}$ (176°F). In addition they shall be suitable for the conditions and correctly installed. Where applicable the provided original parts of the manufacturer must be used.

Conduit system for FM and CSA

In addition the regulations of the country must be observed. The used flameproof seals and blanking elements must have an adequate type approval and a temperature range of at least -40°C (-40°F) to $+80^{\circ}\text{C}$ (176°F). In addition they shall be suitable for the conditions and correctly installed. Where applicable the provided original parts of the manufacturer must be used.

Commissioning

Commissioning only with closed lid.

Opening the lid

Before opening the lid take care, that no dust deposits or whirlings are present. Do not remove the lid (cover) while circuits are alive.

Connection

Connection is done directly on the electronic board

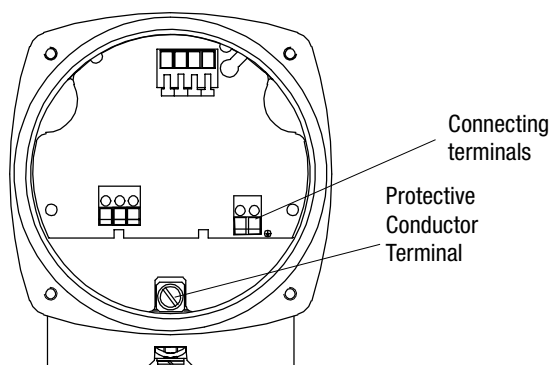

Electrical installation

Universal voltage

Relay DPDT

Power supply:

19..230V 50-60Hz	+10%	18VA
19..50V DC	+10%	2W

Fuse on power supply: max. 10A

Signal output:

Floating relay DPDT

AC max. 250V, 8A, non inductive
 DC max. 30V, 5A, non inductive

Fuse on signal output: max 10A

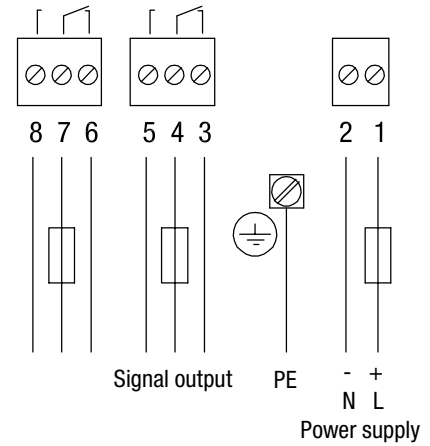

3-wire

PNP

Power supply:

18 .. 50V DC +10% 0.6W

Fuse: max 4A

Signal output:

max. 0.4A

Load for example:

PLC, relay, contactor, bulb

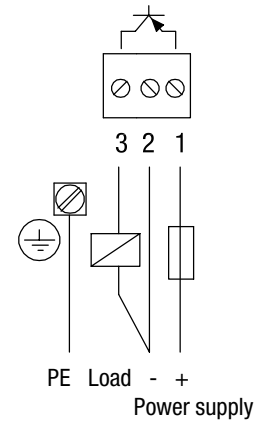

Signal output

FSL / FSH Setting

FSH If the sensor is used to indicate full load, set to Fail Safe High. Power failure or line break is regarded as „full“ signal (protection against overcharging).

FSL If the sensor is used to indicate empty load, set to Fail Safe Low. Power failure or line break is regarded as „empty“ signal (protection against running dry).

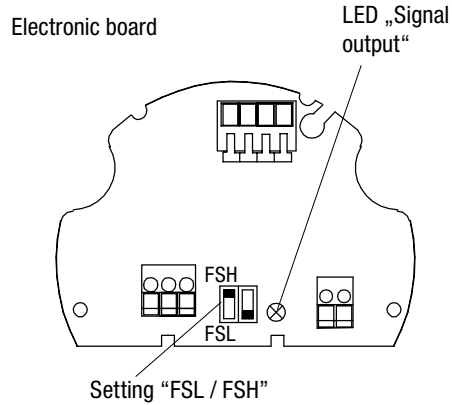

Signal output

Setting	Signal output		Signal output	
	FSL	FSH	FSL	FSH
Relay DTPT				
3-wire PNP				
LED "Signal output"				

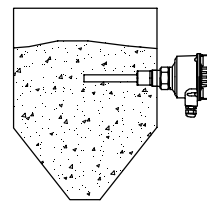
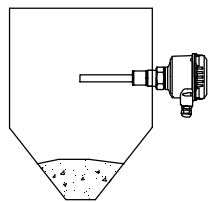

Setting: Sensitivity / Maintenance

Sensitivity

All sensors are factory setted. Therefore, they usually do not have to be re-setted. If the bulk material has a strong propensity to cake or deposit, the setting switch can be set to position „A“ so as to decrease the sensitivity of the probe (Factory presetting = position „B“).

Approximate min. bulk density on setting:

A	B
Low sensitivity	High sensitivity
150g/l (9.5lb/ft³)	60g/l (3.8lb/ft³)

Please contact manufacturer if you intend to use the device for special purposes.

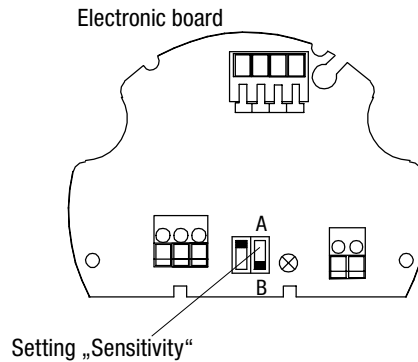

Maintenance

Normally the device requires no maintenance. However, depending on the application, the following should be observed and inspected:

- Mechanically damaged oscillating rods.
- Coarse cleaning of the vibrating fork.

Changing the electronic board.

1. Open the housing lid
2. Remove the field wiring cables
3. Remove the sensor cables
4. Unscrew the two fastening screws of the electronic board
5. Take out the electronic board
6. Insert a new electronic board and tighten fastening screws
7. Connect the sensor cables and field wire cables (see drawing right hand)

Sensor cables

Version VN 4020: Red Yellow Blue Black
 Version VN 4030: Red White Blue Black

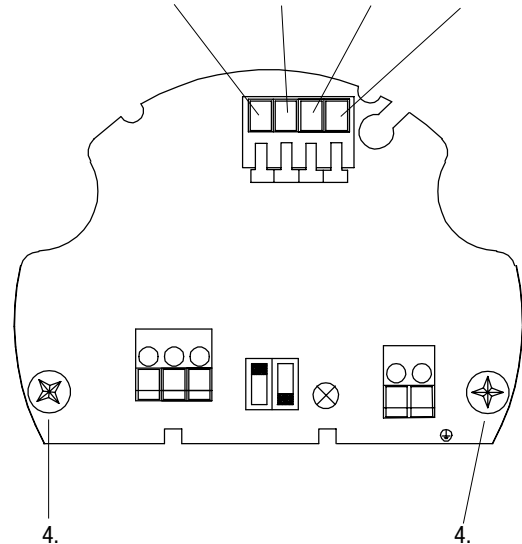

Notes for use in Hazardous Locations

ATEX Zone classification

	category	usable in zone
Dust applications	1 D	20, 21, 22
	2 D	21, 22
	3 D*	22

* in case of conductive dust additional demands for the installation are possible.

General Notes

Marking Devices with EX approval are marked on the name plate.

Process pressure for ATEX  The device construction allows process over-pressure upto 10 bars (145psi). These pressures are allowed for test purposes. The definition of the ATEX is only valid for a container-over-pressure between -0.2..+0.1 bar (-2.9..+1.45psi). For higher or lower pressures the approval is not valid.

Process and ambient temperature The permitted temperature ranges are marked on the name plate.

Permitted zones (categories) for mounting in partition wall

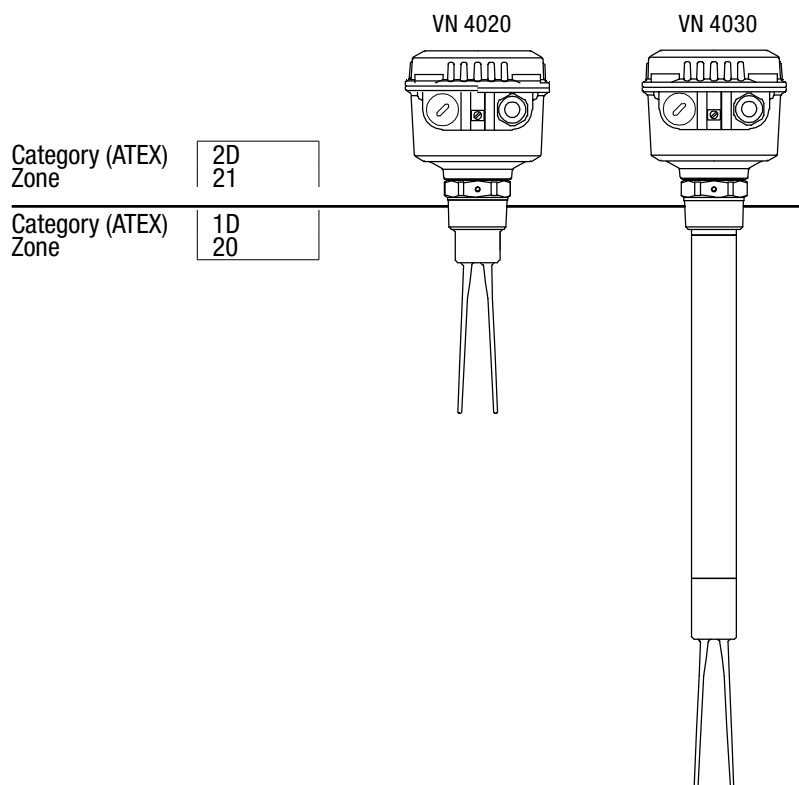

Notes for use in Hazardous Locations

Max. surface temperature and temperature class

The temperature marking on the type plate  refers to the instruction manual. In the following table the relevant temperature ratings are shown.

The maximum surface temperature is the warmest external temperature of the unit which could occur during malfunction (according to EX definition).

The temperature class is the warmest temperature anywhere external or internal to the unit which could occur during malfunction (according to EX definition).

The data in the table is valid, if it is guaranteed, due to the installation, that the thread part has a maximum temperature of 80°C (176°F) at normal use.

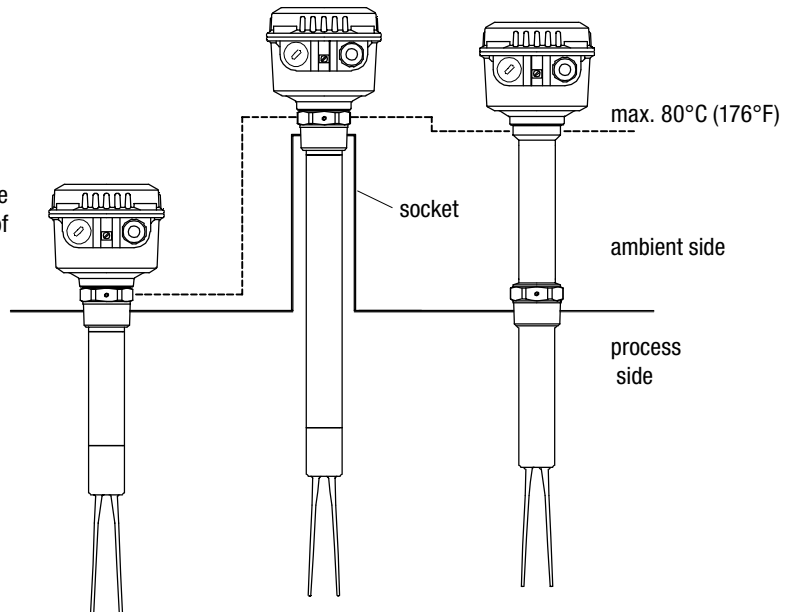

Ratings

Maximum surface temperature:

The maximum surface temperature is relevant for Dust Ex approvals. It is the warmest external temperature of the unit which could occur during malfunction (according to ATEX definition).

Max. ambient temperature	Max. process temperature	Process side	Ambient side
		Max. surface temperature	Max. surface temperature
60°C (140°F)	110°C (230°F)	115°C (239°F)	115°C (239°F)
	120°C (248°F)	120°C (248°F)	
	130°C (266°F)	130°C (266°F)	
	140°C (284°F)	140°C (284°F)	
	150°C (302°F)	150°C (302°F)	

